

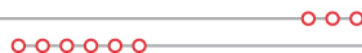

Feasibility Cluster Study for Generation Interconnection Requests (FCS-2013-003)

August 2013

Generator Interconnection



Revision History

Date or Version Number	Author	Change Description	Comments
08/26/2013	Southwest Power Pool	N/A	Report Issued

Executive Summary

Generation Interconnection customers have requested a Feasibility Study under the Generation Interconnection Procedures (GIP) in the Southwest Power Pool Open Access Transmission Tariff (OATT). The Interconnection Customers' requests have been clustered together for the following Feasibility Cluster Study (FCS) window which closed June 30th, 2013. This Feasibility Cluster Study analyzes the interconnecting of a single generation interconnection request totaling approximately 200.1 MW which would be located within the transmission system of Westar Energy Inc. (WERE). The generation interconnection request has a proposed in-service date¹ of July 15, 2014. The generation interconnection request included in this Feasibility Cluster Study is listed in Appendix A by its queue number, amount, requested interconnection service, area, requested interconnection point, proposed interconnection point, and the requested in-service date.

Power flow analysis has indicated that for the power flow cases studied, 200.1 MW of nameplate generation may be interconnected with transmission system reinforcements within the SPP transmission system. The need for reactive compensation in accordance with Order No. 661-A for wind farm interconnection requests will be evaluated in the Preliminary Interconnection System Impact Study (PISIS) and Definitive Interconnection System Impact Study (DISIS) based on the wind turbine manufacturer and type requested by the Customer. Dynamic stability studies performed as part of the PISIS and DISIS Cluster Studies will provide additional guidance as to whether required reactive compensation can be static or a portion must be dynamic (such as a SVC).

In no way does this study guarantee operation for all periods of time. This interconnection study identifies and assigns transmission reinforcements for Energy Resource (ER) interconnection injection constraints (defined as a 20% distribution factor impact) and Network Resource (NR) constraints if requested by the Customer. This interconnection study does not assign transmission reinforcements for all potential transmission constraints. It should be noted that although this study analyzed many of the most probable contingencies, it is not an all-inclusive list and cannot account for every operational situation. Because of this, it is likely that the Customer(s) may be required to reduce their generation output to 0 MW, also known as curtailment, under certain system conditions to allow system operators to maintain the reliability of the transmission network.

The total estimated minimum cost for interconnecting the studied generation interconnection request on the 115kV transmission line is \$67,675,000 and the minimum cost on the 345kV transmission line is \$29,800,000. These costs are shown in Appendices E and F. These costs do not include the Interconnection Customer Interconnection Facilities as defined by the SPP Open Access Transmission Tariff (OATT). This cost does not include the possible need for reactive compensation or additional interconnection facilities or network upgrades that may be identified through additional analyses performed in the PISIS and DISIS.

Network Constraints listed in Appendix I are located in the local area of the new generation when this generation is injected throughout the SPP footprint for the Energy Resource (ER) Interconnection Request. Certain interconnection requests have been studied for Network Resource (NR) Interconnection Service. Those constraints are also listed in Appendix I. Additional

¹ The generation interconnection requests in-service dates will need to be deferred based on the required lead time for the Network Upgrades necessary. The Interconnection Customer's that proceed to the Facility Study will be provided a new in-service date based on the competition of the Facility Study.

Network constraints will have to be verified with a Transmission Service Request (TSR) and associated studies. With a defined source and sink in a TSR, this list of Network Constraints will be refined and expanded to account for all Network Upgrade requirements.

The required interconnection costs listed in Appendix E and F do not include all costs associated with the deliverability of the energy to final customers. These costs are determined by separate studies if the Customer submits a Transmission Service Request through SPP's Open Access Same Time Information System (OASIS) as required by Attachment Z1 of the SPP OATT.

Table of Contents

Revision History	1
Executive Summary	2
Table of Contents	4
Introduction.....	5
Model Development.....	5
Interconnection Requests Included in the Cluster.....	5
Previously Queued Interconnection Requests	5
Development of Base Cases	5
Base Case Upgrades.....	6
Contingent Upgrades.....	6
Regional Groupings	8
Identification of Network Constraints.....	8
Determination of Cost Allocated Network Upgrades.....	9
Credits for Amounts Advanced for Network Upgrades.....	9
Interconnection Facilities	10
Power Flow Analysis.....	10
Power Flow Analysis Methodology	10
Power Flow Analysis.....	10
Conclusion	13
Appendix	14
A: Generation Interconnection Requests Considered for Feasibility Study.....	15
B: Prior Queued Interconnection Requests.....	16
D: Proposed Point of Interconnection One line Diagrams.....	18
E: Cost Allocation per Interconnection Request (Including Prior Queued Upgrades)	19
F: Cost Allocation per Proposed Study Network Upgrade	20
G: FCITC Analysis Constraints Requiring Mitigation (ERIS).....	21
H: FCITC Analysis Constraints Requiring Mitigation (NRIS).....	22
I: FCITC Analysis Constraints Not Requiring Transmission Reinforcement	23

Introduction

Generation Interconnection customers have requested a Feasibility Study under the Generation Interconnection Procedures (GIP) in the Southwest Power Pool Open Access Transmission Tariff (OATT). The Interconnection Customers' requests have been clustered together for the following Feasibility Cluster Study (FCS) window which closed June 30th, 2013. This Feasibility Cluster Study analyzes the interconnecting of a single generation interconnection request totaling approximately 200.1 MW which would be located within the transmission systems of Westar Energy Inc. (WERE). The generation interconnection request has proposed an in-service date² of July 15, 2014. The generation interconnection request included in this Feasibility Cluster Study is listed in Appendix A by its queue number, amount, area, requested interconnection service, requested interconnection point, proposed interconnection point, and the requested in-service date.

The primary objective of this Feasibility Cluster Study is to identify the system constraints associated with connecting the generation to the area transmission system. The Feasibility and other subsequent Interconnection Studies are designed to identify attachment facilities, Network Upgrades and other Direct Assignment Facilities needed to accept power into the grid at each specific interconnection receipt point.

Model Development

Interconnection Requests Included in the Cluster

SPP has included all interconnection requests that submitted a Feasibility Study Agreement no later than 6/30/2013 and were subsequently accepted by Southwest Power Pool under the terms of the Generator Interconnection Procedures (GIP) effective at the time of this study. The interconnection requests that are included in this study are listed in Appendix A.

Previously Queued Interconnection Requests

The previous queued requests included in this study are listed in Appendix B. In addition to the Base Case Upgrades, the previous queued requests and associated upgrades were assumed to be in-service and added to the Base Case models. These projects were dispatched as Energy Resources and or Network Resources (in accordance with the individual Interconnection Requests) with equal distribution across the SPP footprint.

Development of Base Cases

The 2012 series Transmission Service Request (TSR) Models 2013 spring, 2013 summer and winter peak, 2018 summer and winter peak, and 2023 summer peak scenario 0 cases were used for this study. After the cases were developed, each of the control areas' resources were then re-dispatched to account for the new generation requests using current dispatch orders.

² The generation interconnection requests in-service dates will need to be deferred based on the required lead time for the Network Upgrades necessary. The Interconnection Customer's that proceed to the Facility Study will be provided a new in-service date based on the competition of the Facility Study.

Base Case Upgrades

The following facilities are part of the SPP Transmission Expansion Plan or the Balanced Portfolio or recently approved Priority Projects. These facilities, have an approved Notice to Construct (NTC), or are in construction stages and were assumed to be in-service at the time of dispatch and added to the base case models. The FCS-2013-003 Customers have not been assigned cost for the below listed projects. The FCS-2013-003 Customers Generation Facilities in service dates may need to be delayed until the completion of the following upgrades. If for some reason, construction on these projects is discontinued, additional restudies will be needed to determine the interconnection needs of the Feasibility Study customers.

- Balanced Portfolio Projects³:
 - Woodward – Border – TUCO 345kV project, scheduled for 5/19/2014 in-service
 - Woodward 345/138kV circuit #2 autotransformer
 - TUCO 345/138kV circuit #2 autotransformer
 - Reactors at Woodward and Border
 - Iatan– Nashua 345kV, scheduled for 6/1/2015 in-service
 - Nashua 345/161kV autotransformer
 - Muskogee– Seminole 345kV, scheduled for 12/31/2013 in-service
- Priority Projects⁴:
 - Hitchland – Woodward double circuit 345kV, scheduled for 6/30/2014 in-service
 - Hitchland 345/230kV circuit #2 autotransformer
 - Woodward – Thistle double circuit 345kV, scheduled for 12/31/2014 in-service
 - Spearville – Clark County double circuit 345kV, scheduled for 12/31/2014 in-service
 - Clark County – Thistle double circuit 345kV, scheduled for 12/31/2014 in-service
 - Thistle – Wichita double circuit 345kV, scheduled for 12/31/2014 in-service
 - Thistle 345/138kV autotransformer, scheduled for 12/31/2014 in-service
 - Thistle – Flat Ridge 138kV, scheduled for 12/31/2014 in-service
- Sheldon – SW 7th and Pleasant Hill 115kV circuit #2 rebuild, scheduled for 7/31/2013 in-service⁵
- Hays – South Hays 115kV line rebuild, scheduled for 6/1/2015 in-service⁶
- Arcadia – Redbud 345kV circuit #1 and #2 terminal Equipment replacement, scheduled for 11/17/2013 in-service⁷

Contingent Upgrades

The following facilities do not yet have approval. These facilities have been assigned to higher queued interconnection customers. These facilities have been included in the models for the FCS-2013-003 study and are assumed to be in service. This list may not be all inclusive. The FCS-2013-003 Customers at this time do not have responsibility for these facilities but may later be assigned the cost of these facilities if higher queued customers terminate their GIA or withdraw from the interconnection queue. The FCS-2013-003 Customer Generation Facilities in service dates may need to be delayed until the completion of the following upgrades.

- Upgrades assigned to 1st Cluster (ICS-2008-001) Interconnection Customers:

³ Notice to Construct (NTC) issued June 2009

⁴ Notice to Construct (NTC) issued June 2010

⁵ SPP Regional Reliability 2012 ITPNT Project Per SPP-NTC 200171

⁶ SPP Regional Reliability 2013 ITPNT Project Per SPP-NTC 200210

⁷ SPP Regional Reliability 2013 ITPNT Project Per SPP-NTC 200204

- Amarillo - Swisher 230kV circuit #1 Rerate replace line traps
 - Clinton Jct - GEN-2007-032 Tap - Clinton 138kV Rerate
- Upgrades assigned to DISIS-2009-001 Interconnection Customers:
 - Fort Dodge – North Fort Dodge – Spearville 115kV circuit #2 build
 - Fort Randall – Madison County – Kelly 230kV circuit #1 rerate (320MVA)
 - Spearville 345/115kV autotransformer circuit #1 build
- Upgrades assigned to DISIS-2010-001 Interconnection Customers:
 - Switch 2749 – Wildorado 69kV circuit #1 rebuild
- Upgrades assigned to DISIS-2010-002 Interconnection Customers:
 - Dixon County – Twin Church circuit #1 rerate (320 MVA)
- Upgrades assigned to DISIS-2011-001 Interconnection Customers:
 - Beaver County – Buckner 345kV circuit #1 build
 - Beaver County 345kV Expansion (Tap & Tie Hitchland – Woodward circuit #2 into Beaver County 345kV)
 - Spearville – Mullergren – Reno double circuit 345kV build
 - Tatonga – Matthewson – Cimarron 345kV circuit #2 build
 - Tatonga terminal equipment upgrade (1792 MVA)
 - Hoskins – Dixon County – Twin Church 230kV circuit #1 conductor clearance increase
 - (NRIS only) Spearville – Mullergren 230kV circuit #1 rebuild
 - (NRIS only) FPL Switch – Woodward – Mooreland 138kV circuit #1 rebuild
 - (NRIS only) Woodward – Woodward EHV 138kV rebuild
 - (NRIS only) Woodward 138/69kV auto replacement
 - (NRIS only) Woodward (OKGE) – Woodward (WFEC) 69kV rebuild
- Upgrades assigned to DISIS-2011-002 Interconnection Customers:
 - Amoco Wasson – Oxy Tap – Yoakum 230kV circuit #1 replace line traps
 - Harbine – Crete 115kV ckt 1 build
 - Jones – Lubbock South 230kV circuit #2 replace line traps
 - Power System Stabilizers – Install Power System Stabilizers at Jones (Units: 1,2,3,4) and Tolk (Units: 1,2)
 - Mustang – Yoakum 230kV circuit #1 replace line traps
 - West Brock – Sub 967 – Sub 968 – Sub 969 – Sub 974 69kV circuit #1 replace terminal equipment
 - (NRIS only) Allen – Lubbock South 115kV circuit #1 rebuild
 - (NRIS only) Benton – Wichita 345kV circuit #1 rerate (1195MVA)
 - (NRIS only) Chisholm – Maize – Evans Energy Center 138kV circuit #1 rebuild
 - (NRIS only) Duncan – Tosco – Comanche Tap 69kV rebuild
 - (NRIS only) Hydro Carbon Tap – Sub974 69kV circuit #1 rewire CT (63MVA)
 - (NRIS only) Lubbock South 230/115kV Autotransformer build circuit #2
 - (NRIS only) Nebraska City U Syracuse – Sub 970 circuit #1 replace terminal equipment
 - (NRIS only) Yoakum 230/115kV transformer circuit #1 and #2 replacements
- Upgrades assigned to DISIS-2012-001 Interconnection Customers:
 - Holcomb 345/115/13.8kV Transformer circuit #2 build
 - Denver North – Mustang 115kV circuit #1 rebuild
 - Denver South – Mustang 115kV circuit #1 rebuild
- Upgrades assigned to DISIS-2012-002 Interconnection Customers:
 - Dixon County – Rasmussen (WAPA) 230kV circuit #1 build
 - Lake Creek – Lone Wolf 69kV circuit #1 reset CT

- Remington – Fairfax 138kV circuit #1 conductor clearance increase
- TUCO Interchange 345/230/13.2kV Autotransformer circuit #3 build⁸

Potential Upgrades Not in the Base Case

Any potential upgrades that do not have a Notification to Construct (NTC) have not been included in the base case. These upgrades include any identified in the SPP Extra-High Voltage (EHV) overlay plan, or any other SPP planning study other than the upgrades listed above in the previous section.

Regional Groupings

The interconnection requests listed in Appendix A were grouped together in two regional groups based on geographical and electrical impacts. These groupings are shown in Appendix C.

For each interconnection request, the generator was dispatched at 100% of nameplate in each season. In light load seasons (2013 spring), within each group, all study wind generating plants were dispatched at 100% nameplate of maximum generation. In the groups the generator was not a part of the wind generating plants were dispatched at 20% nameplate of maximum generation. These projects were dispatched as Energy Resources with equal distribution across the SPP footprint. Certain projects that requested Network Resource Interconnection Service were dispatched in an additional analysis into the balancing authority of the interconnecting transmission owner. This method allowed for the identification of network constraints that were common to the regional groupings that could then in turn have the mitigating upgrade cost allocated throughout the entire cluster.

Peaking units were not dispatched in the 2013 spring model. To study peaking units' impacts, the 2013 summer and winter, 2018 summer and winter seasonal models were chosen and peaking units were dispatched at 100% of the nameplate rating and wind generating facilities were modeled at 10% of the nameplate rating. Solar units were dispatched at 100% nameplate in summer peak models. Each interconnection request was also modeled separately at 100% nameplate for certain analyses.

Identification of Network Constraints

The initial set of network constraints were found by using PSS® MUST First Contingency Incremental Transfer Capability (FCITC) analysis on the entire cluster grouping dispatched at the various levels mentioned above. These constraints were then screened to determine if any of the generation interconnection requests had at least a 20% Distribution Factor (DF) upon the constraint. Constraints that measured at least a 20% DF from at least one interconnection request were considered for mitigation. Interconnection Requests that were being studied for Network Resource Interconnection Service (NRIS) were studied in the additional NRIS analysis to determine if any constraint had at least a 3% DF. If so, these constraints were considered for mitigation.

Identification of Electrically Isolated Groups and Requests – From the FCITC analysis, it was determined that some of the regional groups had no common impacts with the other groups. However, this determination may change as the Interconnection Customers depending upon the

⁸ TUCO Interchange 345/230/13.2kV Autotransformer circuit #3 might require a new substation adjacent or close to the existing TUCO Interchange substation.

time at which the interconnection customers enter either the Preliminary Interconnection System Impact Study (PISIS) or the Definitive Interconnection System Impact Study (DISIS).

Determination of Cost Allocated Network Upgrades

Cost Allocated Network Upgrades of wind generation interconnection requests were determined using the 2013 spring model. Cost Allocated Network Upgrades of peaking units was determined using the 2018 summer peak model. A PSSE® MUST sensitivity analysis was performed to determine the Distribution Factors (DF), a distribution factor with no contingency that each generation interconnection request had on each new upgrade. The impact each generation interconnection request had on each upgrade project was weighted by the size of each request. Finally the costs due by each request for a particular project were then determined by allocating the portion of each request's impact over the impact of all affecting requests.

For example, assume that there are three Generation Interconnection requests, X, Y, and Z that are responsible for the costs of Upgrade Project '1'. Given that their respective DF for the project have been determined, the cost allocation for Generation Interconnection request 'X' for Upgrade Project 1 is found by the following set of steps and formulas:

- Determine an Impact Factor on a given project for all responsible GI requests:

$$\text{Request X Impact Factor on Upgrade Project 1} = \text{DF}(\%)(X) * \text{MW}(X) = X1$$

$$\text{Request Y Impact Factor on Upgrade Project 1} = \text{DF}(\%)(Y) * \text{MW}(Y) = Y1$$

$$\text{Request Z Impact Factor on Upgrade Project 1} = \text{DF}(\%)(Z) * \text{MW}(Z) = Z1$$

- Determine each request's Allocation of Cost for that particular project:

$$\text{Request X's Project 1 Cost Allocation (\$)} = \frac{\text{Network Upgrade Project 1 Cost(\$)} * X1}{X1 + Y1 + Z1}$$

- Repeat previous for each responsible GI request for each Project

The cost allocation of each needed Network Upgrade is determined by the size of each request and its impact on the given project. This allows for the most efficient and reasonable mechanism for sharing the costs of upgrades.

Credits for Amounts Advanced for Network Upgrades

Interconnection Customer shall be entitled to credits in accordance with Attachment Z2 of the SPP Tariff for any Network Upgrades including any tax gross-up or any other tax-related payments associated with the Network Upgrades, and not refunded to the Interconnection Customer.

Interconnection and Network Upgrade Facilities

The generator interconnection Customer requested that two separate points of interconnection (POI) be analyzed. The first POI studied is the WERE Florence Junction 115 kV, and the second POI studied is a tap on the WERE Wichita – Emporia Energy Center 345 kV transmission line near Potwin, Kansas. The requirement to interconnect the 200.1 MW of generation into the existing and proposed transmission systems in the affected areas of the SPP transmission footprint consist of the necessary cost allocated shared facilities listed in Appendices E and F with an approximate cost of \$67,675,000 for the 115kV POI selection or \$29,800,000 for the 345kV POI selection. Appendices E and F also include Interconnection Facilities specific to each generation interconnection request.

A list of constraints with greater than or equal to a 20% DF that were identified and proposed transmission reinforcements for mitigation are listed in Appendix G and H. Other Network Constraints, those between 3% and 20% DF, which did not propose transmission reinforcements for mitigation, are shown in Appendix I. With a defined source and sink in a TSR, this list of Network Constraints will be refined and expanded to account for all Network Upgrade requirements.

A preliminary one-line drawing for each generation interconnection request are listed in Appendix D.

Power Flow Analysis

Power Flow Analysis Methodology

The FCITC function of PSS® MUST was used to simulate single element and special (i.e., breaker-to-breaker, multi-element, etc) contingencies in portions or all of the modeled control areas of SPP, as well as, other control areas external to SPP and the resulting scenarios analyzed. This satisfies the “more probable” contingency testing criteria mandated by NERC and the SPP criteria.

Power Flow Analysis

A power flow analysis was conducted for each Interconnection Customer’s facility using modified versions of the 2013 (spring, summer, and winter) peak, the 2018 (summer and winter) peak and 2023 summer peak models. The output of the Interconnection Customer’s facility was offset in each model by a reduction in output of existing online SPP generation. This method allows the request to be studied as an Energy Resource (ER) Interconnection Request. Certain requests that requested Network Resource Interconnection Service (NRIS) had an additional analysis conducted for displacing resources in the interconnecting Transmission Owner’s balancing authority.

This analysis was conducted assuming that previous queued requests in the immediate area of these interconnect requests were in-service. The analysis of the each Customer’s project indicates that criteria violations will occur on the WERE transmission systems under steady state and contingency conditions in the peak seasons.

The need for reactive compensation will be determined during the Interconnection System Impact Study. The need for reactive compensation will be based on the Interconnection Customer’s choice of wind turbine make and manufacturer. Dynamic Stability studies performed as part of the System Impact Cluster Study will provide additional guidance as to whether the reactive compensation can

be static or a portion must be dynamic (such as a SVC or STATCOM). It is possible that an SVC or STATCOM device will be required at the Customer facility because of FERC Order 661A Low Voltage Ride-Through Provisions (LVRT) which went into effect January 1, 2006. FERC Order 661A orders that wind farms stay on-line for 3-phase faults at the point of interconnection even if that requires the installation of a SVC or STATCOM device.

Cluster Group 8 (South Central Kansas/North Oklahoma)

In addition to the 3,081.42 MW of previously queued generation in the area, 200.1 MW of new interconnection service was studied. The Interconnection Customer requested the evaluation of two different and mutually exclusive Points of Interconnection. One option was on the 115kV WERE system and the second option was on the 345kV WERE system.

For the 115 kV POI option, constraints were observed primarily around the Florence substation for These constraints require rebuilding the Florence – Spring Creek 115kV circuit #1, Florence – Williams Brothers Pipeline Co 115kV circuit #1, Moundridge – Spring Creek 115kV circuit #1, West Emporia – Williams Brothers Pipeline Co 115kV circuit #1 and the addition of a second 138/115/13.8kV transformer at Moundridge. NRIS service constraints require rebuilds on Chisholm – Maize East 138kV circuit #1, Evans Energy Center North – Maize West 138kV circuit #1 (which are previously allocated) and the Moundridge – Yost 69kV circuit #1.

For the interconnection on the Wichita – Emporia Energy Center 345kV transmission line, there were NRIS only service constraints which require rebuilds on Chisholm – Maize East 138kV circuit #1, Evans Energy Center North – Maize West 138kV circuit #1 (which are previously allocated) and a 3rd 345/138/13.8kV transformer at Wichita.

MONITORED ELEMENT	RATE B (MVA)	TC%LOADING (% MVA)	CONTINGENCY
FLORENCE JUNCTION - SPRING CREEK JUNCTION 115KV CKT 1	79.9	239.6746	FLORENCE JUNCTION - WILLIAMS BROTHERS PIPELINE COMPANY JUNCTION 115KV CKT 1
FLORENCE JUNCTION - WILLIAMS BROTHERS PIPELINE COMPANY JUNCTION 115KV CKT 1	80	239.375	FLORENCE JUNCTION - SPRING CREEK JUNCTION 115KV CKT 1
MOUNDRIDGE - SPRING CREEK JUNCTION 115KV CKT 1	80	225.625	FLORENCE JUNCTION - WILLIAMS BROTHERS PIPELINE COMPANY JUNCTION 115KV CKT 1
MOUNDRIDGE (MOUND10X) 138/115/13.8KV TRANSFORMER CKT 1	110	127.3455	FLORENCE JUNCTION - WILLIAMS BROTHERS PIPELINE COMPANY JUNCTION 115KV CKT 1
WEST EMPORIA - WILLIAMS BROTHERS PIPELINE COMPANY JUNCTION 115KV CKT 1	79.8	239.7243	FLORENCE JUNCTION - SPRING CREEK JUNCTION 115KV CKT 1
CHISHOLM - MAIZEE 4 138.00 138KV CKT 1	382	102.1817	BENTON - WICHITA 345KV CKT 1
EVANS ENERGY CENTER NORTH - MAIZEW 4 138.00 138KV CKT 1	381.5	106.9027	BENTON - WICHITA 345KV CKT 1
MOUNDRIDGE - YOST 69KV CKT 1	71.8	111.0808	HALSTEAD NORTH BUS - MOUNDRIDGE 138KV CKT 1
CHISHOLM - MAIZEE 4 138.00 138KV CKT 1	381.9	112.1713	BENTON - WICHITA 345KV CKT 1
EVANS ENERGY CENTER NORTH - MAIZEW 4 138.00 138KV CKT 1	381.4	118.1914	BENTON - WICHITA 345KV CKT 1
WICHITA (WICHT11X) 345/138/13.8KV TRANSFORMER CKT 1	436.7	106.8289	WICHITA (WICHT12X) 345/138/13.8KV TRANSFORMER CKT 1
WICHITA (WICHT12X) 345/138/13.8KV TRANSFORMER CKT 1	435.4	113.9793	WICHITA (WICHT11X) 345/138/13.8KV TRANSFORMER CKT 1

Curtailment and System Reliability

In no way does this study guarantee operation for all periods of time. It should be noted that although this study analyzed many of the most probable contingencies, it is not an all-inclusive list and cannot account for every operational situation. Because of this, it is likely that the Customer(s) may be required to reduce their generation output to 0 MW, also known as curtailment, under certain system conditions to allow system operators to maintain the reliability of the transmission network.

Conclusion

The minimum cost of interconnecting 200.1 MW of new interconnection requests included in this Feasibility Cluster Study is estimated at \$67,675,000 for the 115kV POI option or \$29,800,000 for the 345kV POI option including the Allocated Network Upgrades and Transmission Owner Interconnection Facilities, which are listed in Appendices E and F. These costs do not include the cost of upgrades of other transmission facilities listed in Appendix H which are Network Constraints.

These interconnection costs do not include any cost of Network Upgrades determined to be required by AC power flow, short circuit or transient stability analysis. These studies will be performed if the Interconnection Customer executes the appropriate Interconnection System Impact Study Agreement and provides the required data along with demonstration of Site Control and the appropriate deposit. At the time of the System Impact Cluster Study, a better determination of the interconnection facilities may be available.

The required interconnection costs listed in Appendices E and F, and other upgrades associated with Network Constraints do not include all costs associated with the deliverability of the energy to final customers. These costs are determined by separate studies if the Customer submits a Transmission Service Request (TSR) through SPP's Open Access Same Time Information System (OASIS) as required by Attachment Z1 of the SPP Open Access Transmission Tariff (OATT).

Appendix

A: Generation Interconnection Requests Considered for Feasibility Study

A: Generation Interconnection Requests Considered for Feasibility Study

Request	Amount	Service	Area	Requested Point of Interconnection	Proposed Point of Interconnection	Requested In-Service Date	In Service Date Delayed Until no earlier than*
GEN-2013-020	200.10	ER/NR	WERE	Florence Jct 115kV or Tap Wichita - Emporia Energy Center 345kV		7/15/2014	TBD

Total: 200.10

*Requests that dependent upon Priority Projects or Balanced Portfolio may be delayed until 12/31/2014. Other requests in-service date to be determined after Facility Study.

B: Prior Queued Interconnection Requests

B: Prior Queued Interconnection Requests

Request	Amount	Area	Requested/Proposed Point of Interconnection	Status or In-Service Date
ASGI-2010-006	150.00	AECI	Tap Fairfax (AECI) - Shilder (AEPW) 138kV	AECI queue Affected Study
ASGI-2010-010	42.20	SPS	Lovington 115kV	Lea County Affected Study
ASGI-2010-020	30.00	SPS	Tap LE-Tatum - LE-Crossroads 69kV	Lea County Affected Study
ASGI-2010-021	15.00	SPS	Tap LE-Saunders Tap - LE-Anderson 69kV	Lea County Affected Study
ASGI-2011-001	28.80	SPS	Lovington 115kV	On-Line
ASGI-2011-002	10.00	SPS	Herring 115kV	On-Line
ASGI-2011-003	10.00	SPS	Hendricks 115kV	On-Line
ASGI-2011-004	20.00	SPS	Pleasant Hill 69kV	Under Study (DISIS-2011-002)
ASGI-2012-002	18.15	SPS	FE-Clovis Interchange 115kV	Under Study (DISIS-2012-002)
ASGI-2012-006	22.50	SUNCMKEC	Tap Hugoton - Rolla 69kV	Under Study (DISIS-2012-001)
ASGI-2013-001	12.78	SPS	PanTex South 115kV	
ASGI-2013-002	18.40	SPS	FE Tucumcari 115kV	
ASGI-2013-003	18.40	SPS	FE Clovis 115kV	
GEN-2001-014	96.00	WFEC	Ft Supply 138kV	On-Line
GEN-2001-026	74.00	WFEC	Washita 138kV	On-Line
GEN-2001-033	180.00	SPS	San Juan Tap 230kV	On-Line at 120MW
GEN-2001-036	80.00	SPS	Norton 115kV	On-Line
GEN-2001-037	102.00	OKGE	FPL Moreland Tap 138kV	On-Line
GEN-2001-039A	105.00	SUNCMKEC	Tap Greensburg - Ft Dodge (Shooting Star Tap) 115kV	On-Line
GEN-2001-039M	99.00	SUNCMKEC	Central Plains Tap 115kV	On-Line
GEN-2002-004	200.00	WERE	Latham 345kV	On-Line at 150MW
GEN-2002-005	120.00	WFEC	Red Hills Tap 138kV	On-Line
GEN-2002-008	240.00	SPS	Hitchland 345kV	On-Line at 120MW
GEN-2002-009	80.00	SPS	Hansford 115kV	On-Line
GEN-2002-022	240.00	SPS	Bushland 230kV	On-Line
GEN-2002-023N	0.80	NPPD	Harmony 115kV	On-Line
GEN-2002-025A	150.00	SUNCMKEC	Spearville 230kV	On-Line
GEN-2003-004	100.00	WFEC	Washita 138kV	On-Line
GEN-2003-005	100.00	WFEC	Anadarko - Paradise (Blue Canyon) 138kV	On-Line
GEN-2003-006A	200.00	SUNCMKEC	Elm Creek 230kV	On-Line
GEN-2003-019	250.00	MIDW	Smoky Hills Tap 230kV	On-Line
GEN-2003-020	160.00	SPS	Martin 115kV	On-Line
GEN-2003-021N	75.00	NPPD	Ainsworth Wind Tap 115kV	On-Line
GEN-2003-022	120.00	AEPW	Washita 138kV	On-Line
GEN-2004-005N	30.00	NPPD	St Francis 115kV	On Suspension
GEN-2004-014	154.50	SUNCMKEC	Spearville 230kV	On-Line at 100MW
GEN-2004-020	27.00	AEPW	Washita 34.5kV	On-Line
GEN-2004-023	20.60	WFEC	Washita 138kV	On-Line
GEN-2004-023N	75.00	NPPD	Columbus Co 115kV	On-Line
GEN-2005-003	30.60	WFEC	Washita 138kV	On-Line
GEN-2005-008	120.00	OKGE	Woodward 138kV	On-Line
GEN-2005-012	250.00	SUNCMKEC	Spearville 345kV	On-Line at 160MW
GEN-2005-013	201.00	WERE	Tap Latham - Neosho (Caney River) 345kV	On-Line
GEN-2006-002	101.00	AEPW	Sweetwater 230kV	On-Line
GEN-2006-006	205.50	SUNCMKEC	Spearville 345kV	On Schedule for 2015

Request	Amount	Area	Requested/Proposed Point of Interconnection	Status or In-Service Date
GEN-2006-010	620.00	AEPW	Turk 138kV	On-Line
GEN-2006-018	170.00	SPS	TUCO Interchange 230kV	On-Line
GEN-2006-020N	42.00	NPPD	Bloomfield 115kV	On-Line
GEN-2006-020S	18.90	SPS	DWS Frisco 115kV	On-Line
GEN-2006-021	101.00	SUNCMKEC	Flat Ridge Tap 138kV	On-Line
GEN-2006-022	150.00	SUNCMKEC	Ninnescah 115kV	On Schedule for 2014
GEN-2006-024S	19.80	WFEC	Buffalo Bear Tap 69kV	On-Line
GEN-2006-026	604.00	SPS	Hobbs 230kV & Hobbs 115kV	On-Line
GEN-2006-031	75.00	MIDW	Knoll 115kV	On-Line
GEN-2006-035	225.00	AEPW	Sweetwater 230kV	On-Line at 132MW
GEN-2006-037N1	75.00	NPPD	Broken Bow 115kV	On Schedule for 2014
GEN-2006-038N005	80.00	NPPD	Broken Bow 115kV	On-Line
GEN-2006-038N019	80.00	NPPD	Petersburg North 115kV	On-Line
GEN-2006-040	108.00	SUNCMKEC	Mingo 115kV	On Suspension
GEN-2006-043	99.00	AEPW	Sweetwater 230kV	On-Line
GEN-2006-044	370.00	SPS	Hitchland 345kV	On-Line at 80MW
GEN-2006-044N	40.50	OPPD	North Petersburg 115kV	On-Line
GEN-2006-046	131.00	OKGE	Dewey 138kV	On-Line
GEN-2006-047	240.00	SPS	Tap Bushland - Deaf Smith (Buffalo) 230kV	On Suspension
GEN-2007-011	135.00	SUNCMKEC	Syracuse 115kV	On Suspension
GEN-2007-011N08	81.00	NPPD	Bloomfield 115kV	On-Line
GEN-2007-021	201.00	OKGE	Tatonga 345kV	On Schedule for 2014
GEN-2007-025	300.00	WERE	Viola 345kV	On-Line
GEN-2007-032	150.00	WFEC	Tap Clinton Junction - Clinton 138kV	On Schedule for 2013
GEN-2007-038	200.00	SUNCMKEC	Spearville 345kV	On Schedule for 2015
GEN-2007-040	200.00	SUNCMKEC	Buckner 345kV	On-Line at 132MW
GEN-2007-043	200.00	OKGE	Minco 345kV	On-Line
GEN-2007-044	300.00	OKGE	Tatonga 345kV	On Schedule for 2014
GEN-2007-046	199.50	SPS	Hitchland 115kV	On Schedule for 2014
GEN-2007-048	400.00	SPS	Tap Amarillo S - Swisher 230kV	On Schedule for 2014
GEN-2007-050	170.00	OKGE	Woodward EHV 138kV	On-Line at 150MW
GEN-2007-052	150.00	WFEC	Anadarko 138kV	On-Line
GEN-2007-062	765.00	OKGE	Woodward EHV 345kV	On Schedule for 2014
GEN-2008-003	101.00	OKGE	Woodward EHV 138kV	On-Line
GEN-2008-008	60.00	SPS	Graham 69kV	On Suspension
GEN-2008-009	60.00	SPS	San Juan Tap 230kV	On Schedule for 2014
GEN-2008-013	300.00	OKGE	Tap Wichita - Woodring (Hunter) 345kV	On-Line at 235MW
GEN-2008-017	300.00	SUNCMKEC	Setab 345kV	On Schedule for 2015
GEN-2008-018	405.00	SPS	Finney 345kV	On Schedule for 2014
GEN-2008-019	300.00	OKGE	Tatonga 345kV	On Schedule for 2015
GEN-2008-021	42.00	WERE	Wolf Creek 345kV	On-Line
GEN-2008-022	300.00	SPS	Tap Eddy Co - Tolk (Chaves County) 345kV	On Schedule for 2015
GEN-2008-023	150.00	AEPW	Hobart Junction 138kV	On-Line
GEN-2008-029	250.00	OKGE	Woodward EHV 138kV	On Schedule for 2014
GEN-2008-037	101.00	WFEC	Tap Washita - Blue Canyon Wind 138kV	On-Line
GEN-2008-044	197.80	OKGE	Tatonga 345kV	On-Line
GEN-2008-047	300.00	SPS	Tap Hitchland - Woodward Ckt 1 (Beaver County) 345kV	IA Pending
GEN-2008-051	322.00	SPS	Potter County 345kV	On-Line at 161MW

Request	Amount	Area	Requested/Proposed Point of Interconnection	Status or In-Service Date
GEN-2008-071	76.80	OKGE	Newkirk 138kV	On Suspension
GEN-2008-079	98.90	SUNCMKEC	Tap Cudahy - Ft Dodge 115kV	On-Line
GEN-2008-086N02	200.00	NPPD	Tap Ft Randle - Columbus (Madison County) 230kV	On Schedule for 2014
GEN-2008-088	50.60	SPS	Vega 69kV	On Schedule for 2014
GEN-2008-092	201.00	MIDW	Knoll 230kV	IA Pending
GEN-2008-098	100.80	WERE	Tap Lacygne - Wolf Creek (Anderson County) 345kV	On Schedule for 2015
GEN-2008-1190	60.00	OPPD	S1399 161kV	On-Line
GEN-2008-123N	89.70	NPPD	Tap Guide Rock - Pauline 115kV	On Schedule for 2014
GEN-2008-124	200.00	SUNCMKEC	Spearville 345kV	On Schedule for 2016
GEN-2008-124T	42.00	SPS	TC-Keyes Texas County 69kV	On Schedule for 2014
GEN-2008-129	80.00	MIPU	Pleasant Hill 161kV	On-Line
GEN-2009-008	199.50	MIDW	South Hays 230kV	On Schedule for 2015
GEN-2009-020	48.60	MIDW	Tap Nekoma - Bazine 69kV	On Schedule for 2015
GEN-2009-025	60.00	OKGE	Tap Deer Creek - Sinclair Blackwell 69kV	On-Line
GEN-2009-040	73.80	WERE	Marshall 115kV	On Schedule for 2015
GEN-2010-001	300.00	SPS	Tap Hitchland - Woodward Ckt 1 (Beaver County) 345kV	On Schedule for 2014 (204 MW) and 2015 (96 MW)
GEN-2010-003	100.80	WERE	Tap Lacygne - Wolf Creek (Anderson County) 345kV	On Schedule for 2015
GEN-2010-005	300.00	WERE	Viola 345kV	On-Line at 114MW
GEN-2010-006	205.00	SPS	Jones 230kV	On-Line
GEN-2010-009	165.60	SUNCMKEC	Buckner 345kV	On-Line
GEN-2010-011	30.00	OKGE	Tatonga 345kV	On Line
GEN-2010-014	358.80	SPS	Hitchland 345kV	On Schedule for 2016
GEN-2010-015	200.10	SUNCMKEC	Spearville 345kV	On Schedule for 2015
GEN-2010-020	20.00	SPS	Roswell 69kV	On Suspension
GEN-2010-036	4.60	WERE	6th Street 115kV	On-Line
GEN-2010-040	300.00	OKGE	Cimarron 345kV	On-Line
GEN-2010-041	10.50	OPPD	S 1399 161kV	IA Pending
GEN-2010-044	99.00	NPPD	Harbine 115kV	IA Pending
GEN-2010-045	197.80	SUNCMKEC	Buckner 345kV	IA Pending
GEN-2010-046	56.00	SPS	TUCO Interchange 230kV	On Schedule for 2016
GEN-2010-048	70.00	MIDW	Tap Beach Station - Redline 115kV	IA Pending
GEN-2010-051	200.00	NPPD	Tap Twin Church - Hoskins 230kV	On Schedule for 2014
GEN-2010-055	4.50	AEPW	Wekiwa 138kV	On-Line
GEN-2010-056	151.20	MIPU	Tap Saint Joseph - Cooper 345kV	On Suspension
GEN-2010-057	201.00	MIDW	Rice County 230kV	On-Line
GEN-2010-058	20.00	SPS	Chaves County 115kV	On Suspension
GEN-2010-061	180.00	MIDW	Tap Post Rock - Spearville (GEN-2011-017T) 345kV	Facility Study
GEN-2011-007	250.00	OKGE	Tap Cimarron - Woodring (Matthewson) 345kV	On Schedule for 2014
GEN-2011-008	600.00	SUNCMKEC	Clark County 345kV	IA Pending
GEN-2011-010	100.80	OKGE	Minco 345kV	On-Line
GEN-2011-011	50.00	KACP	Iatan 345kV	On-Line
GEN-2011-012	104.50	SPS	Tap Moore County - Hitchland 345kV	IA Pending
GEN-2011-014	201.00	SPS	Tap Hitchland - Woodward Ckt 1 (Beaver County) 345kV	IA Pending
GEN-2011-016	200.10	SUNCMKEC	Spearville 345kV	IA Pending
GEN-2011-017	299.00	SUNCMKEC	Tap Spearville - PostRock (GEN-2011-017T) 345kV	IA Pending
GEN-2011-018	73.60	NPPD	Steele City 115kV	On Schedule for 2013
GEN-2011-019	299.00	OKGE	Woodward 345kV	IA Pending
GEN-2011-020	299.00	OKGE	Woodward 345kV	IA Pending

Request	Amount	Area	Requested/Proposed Point of Interconnection	Status or In-Service Date
GEN-2011-021	299.00	SPS	Beaver County 345kV	IA Pending
GEN-2011-022	299.00	SPS	Hitchland 345kV	IA Pending
GEN-2011-023	299.00	SUNCMKEC	Clark County 345kV	IA Pending
GEN-2011-024	299.00	OKGE	Tatonga 345kV	Withdrawn
GEN-2011-025	82.30	SPS	Tap Floyd County - Crosby County 115kV	On Suspension
GEN-2011-027	120.00	NPPD	Hoskins 230kV	IA Pending
GEN-2011-037	7.00	WFEC	Blue Canyon 5 138kV	On-Line
GEN-2011-040	111.00	OKGE	Tap Ratliff - Pooleville 138kV	On Schedule for 2014
GEN-2011-043	150.00	SUNCMKEC	Thistle 345kV	Facility Study
GEN-2011-044	150.00	SUNCMKEC	Thistle 345kV	Facility Study
GEN-2011-045	205.00	SPS	Jones 230kV	On-Line
GEN-2011-046	27.00	SPS	Lopez 115kV	On Schedule for 2013
GEN-2011-048	175.00	SPS	Mustang 230kV	On Schedule for 2014
GEN-2011-049	250.00	OKGE	Border 345kV	IA Pending
GEN-2011-050	109.80	AEPW	Tap Rush Springs - Marlow 138kV	IA Pending
GEN-2011-051	104.40	OKGE	Tap Woodward - Tatonga 345kV	IA Pending
GEN-2011-054	300.00	OKGE	Cimarron 345kV	On Schedule for 2013 (200 MW) and 2014 (99 MW)
GEN-2011-055	52.80	OPPD	South Sterling 69kV	Facility Study
GEN-2011-056	3.60	NPPD	Jeffrey 115kV	On-Line
GEN-2011-056A	3.60	NPPD	John 1 115kV	On-Line
GEN-2011-056B	4.50	NPPD	John 2 115kV	On-Line
GEN-2011-057	150.40	WERE	Creswell 138kV	On Schedule for 2014
GEN-2012-001	61.20	SPS	Tap Grassland - Borden County 230kV	On-Line
GEN-2012-002	101.20	SUNCMKEC	Tap Pile - Scott City 115kV	IA Pending
GEN-2012-004	41.40	OKGE	Tap Ratliff - Pooleville 138kV	On Schedule for 2014
GEN-2012-005	81.00	NPPD	Tap Fort Randall - Columbus (North of Madison Co) 230kV	DISIS STAGE
GEN-2012-007	120.00	SUNCMKEC	Rubart 115kV	IA Pending
GEN-2012-008	40.00	SPS	Mustang 115kV & Mustang 230kV	Facility Study
GEN-2012-009	15.00	SPS	Mustang 230kV	Facility Study
GEN-2012-010	15.00	SPS	Mustang 230kV	Facility Study
GEN-2012-011	200.00	SUNCMKEC	Tap Spearville - Post Rock 345kV (North of GEN-2011-017 Tap)	Facility Study
GEN-2012-016	312.00	OKGE	Tap Woodward - Thistle 345kV Ckt 1	Facility Study
GEN-2012-017	115.00	NPPD	Cooper 345kV	Withdrawn
GEN-2012-018	200.00	NPPD	Tap Hoskins - Twin Church 230kV (GEN-2010-051T)	Facility Study
GEN-2012-020	477.12	SPS	TUCO 230kV	Facility Study
GEN-2012-021	4.80	LES	Terry Bundy Generating Station 115kV	Facility Study
GEN-2012-023	115.00	WERE	Viola 345kV	Facility Study
GEN-2012-024	180.00	SUNCMKEC	Clark County 345kV	Facility Study
GEN-2012-026	100.00	MIDW	Colby 115kV	Facility Study
GEN-2012-027	136.00	AEPW	Shidler 138kV	Facility Study
GEN-2012-028	74.80	WFEC	Gotebo 69kV	Facility Study
GEN-2012-031	200.10	OKGE	Cimarron 345kV (GEN-2010-040 Sub)	Facility Study
GEN-2012-032	300.00	OKGE	Tap Rose Hill - Sooner 345kV	Facility Study
GEN-2012-033	98.82	OKGE	Tap and Tie South 4th - Bunch Creek & Enid Tap - Fairmont (GEN-2012-033T) 138kV	Facility Study
GEN-2012-034	7.00	SPS	Mustang 230kV	Facility Study
GEN-2012-035	7.00	SPS	Mustang 230kV	Facility Study

Request	Amount	Area	Requested/Proposed Point of Interconnection	Status or In-Service Date
GEN-2012-036	7.00	SPS	Mustang 230kV	Under Study (DISIS-2012-002)
GEN-2012-037	203.00	SPS	TUCO 345kV	Facility Study
GEN-2012-040	76.50	WFEC	Newkirk 138kV	Facility Study
GEN-2012-041	121.50	OKGE	Tap Rose Hill - Sooner 345kV	IA Pending
GEN-2013-002	50.60	LES	Tap Sheldon - Folsom 115kV CKT 1	DISIS STAGE
GEN-2013-003	48.00	OKGE	Tap Woodwad - Thistle 345kV CKT (GEN-2012-016 Tap)	DISIS STAGE
GEN-2013-003	48.00	OKGE	Tap Woodwad - Thistle 345kV CKT (GEN-2012-016 Tap)	DISIS STAGE
GEN-2013-004	6.00	NPPD	Tap Fort Randall - Columbus (Madison County)	DISIS STAGE
GEN-2013-005	73.50	NPPD	Madison County (GEN-2008-086N2 Sub)	DISIS STAGE
GEN-2013-006	50.60	NPPD	Tap Fort Randall - Columbus (Madison County)	DISIS STAGE
GEN-2013-007	100.30	OKGE	Tap Prices Falls - Carter 138kV	DISIS STAGE
GEN-2013-008	1.20	NPPD	Steele City 115kV	DISIS STAGE
GEN-2013-009	100.30	AEPW	Tap Alluwe Tap - Vinita Junction 138kV	DISIS STAGE
GEN-2013-010	99.00	SUNCMKEC	Tap Spearville - Post Rock 345kV (GEN-2012-011 Tap)	DISIS STAGE
GEN-2013-011	30.00	AEPW	Turk 138kV	DISIS STAGE
GEN-2013-012	147.00	OKGE	Redbud 345kV	DISIS STAGE
GEN-2013-012	147.00	OKGE	Redbud 345kV	DISIS STAGE
GEN-2013-012	147.00	OKGE	Redbud 345kV	DISIS STAGE
GEN-2013-012	147.00	OKGE	Redbud 345kV	DISIS STAGE
GEN-2013-013	248.40	SPS	Tap Eddy County - Tolk 345kV	DISIS STAGE
GEN-2013-014	25.50	NPPD	Tap Guide Rock - Pauline (GEN-2008-123N Tap) 115kV	DISIS STAGE
GEN-2013-015	125.80	NPPD	Tap Pauline - Hildreth 115kV	DISIS STAGE
GEN-2013-016	191.00	SPS	TUCO 345kV	DISIS STAGE
GEN-2013-017	200.00	SPS	Tap TUCO - OKU 345kV	DISIS STAGE
GEN-2013-018	51.00	OPPD	Tap S974 - Hydrocarbon Tap 69kV	DISIS STAGE
Gray County Wind (Montezuma)	110.00	SUNCMKEC	Gray County Tap 115kV	On-Line
Llano Estacado (White Deer)	80.00	SPS	Llano Wind 115kV	On-Line
NPPD Distributed (Broken Bow)	8.30	NPPD	Broken Bow 115kV	On-Line
NPPD Distributed (Burwell)	3.00	NPPD	Ord 115kV	On-Line
NPPD Distributed (Columbus Hydro)	45.00	NPPD	Columbus 115kV	On-Line
NPPD Distributed (North Platte - Lexington)	54.00	NPPD	Multiple: Jeffrey 115kV, John_1 115kV, John_2 115kV	On-Line
NPPD Distributed (Ord)	10.80	NPPD	Ord 115kV	On-Line
NPPD Distributed (Stuart)	2.10	NPPD	Ainsworth 115kV	On-Line
SPS Distributed (Dumas 19th St)	20.00	SPS	Dumas 19th Street 115kV	On-Line
SPS Distributed (Etter)	20.00	SPS	Etter 115kV	On-Line
SPS Distributed (Hopi)	10.00	SPS	Hopi 115kV	On-Line
SPS Distributed (Jal)	10.00	SPS	S Jal 115kV	On-Line
SPS Distributed (Lea Road)	10.00	SPS	Lea Road 115kV	On-Line
SPS Distributed (Monument)	10.00	SPS	Monument 115kV	On-Line
SPS Distributed (Moore E)	25.00	SPS	Moore East 115kV	On-Line
SPS Distributed (Ocotillo)	10.00	SPS	Ocotillo 115kV	On-Line
SPS Distributed (Sherman)	20.00	SPS	Sherman 115kV	On-Line
SPS Distributed (Spearman)	10.00	SPS	Spearman 69kV	On-Line
SPS Distributed (TC-Texas County)	20.00	SPS	Texas County 115kV	On-Line
Total:		30,634.6		

C: Study Groupings

C. Study Groups

GROUP 1: WOODWARD AREA			
Request	Capacity	Area	Proposed Point of Interconnection
GEN-2001-014	96.00	WFEC	Ft Supply 138kV
GEN-2001-037	102.00	OKGE	FPL Moreland Tap 138kV
GEN-2005-008	120.00	OKGE	Woodward 138kV
GEN-2006-024S	19.80	WFEC	Buffalo Bear Tap 69kV
GEN-2006-046	131.00	OKGE	Dewey 138kV
GEN-2007-021	201.00	OKGE	Tatonga 345kV
GEN-2007-043	200.00	OKGE	Minco 345kV
GEN-2007-044	300.00	OKGE	Tatonga 345kV
GEN-2007-050	170.00	OKGE	Woodward EHV 138kV
GEN-2007-062	765.00	OKGE	Woodward EHV 345kV
GEN-2008-003	101.00	OKGE	Woodward EHV 138kV
GEN-2008-019	300.00	OKGE	Tatonga 345kV
GEN-2008-029	250.00	OKGE	Woodward EHV 138kV
GEN-2008-044	197.80	OKGE	Tatonga 345kV
GEN-2010-011	30.00	OKGE	Tatonga 345kV
GEN-2010-040	300.00	OKGE	Cimarron 345kV
GEN-2011-007	250.00	OKGE	Tap Cimarron - Woodring (Matthewson) 345kV
GEN-2011-010	100.80	OKGE	Minco 345kV
GEN-2011-019	299.00	OKGE	Woodward 345kV
GEN-2011-020	299.00	OKGE	Woodward 345kV
GEN-2011-024	299.00	OKGE	Tatonga 345kV
GEN-2011-051	104.40	OKGE	Tap Woodward - Tatonga 345kV
GEN-2011-054	300.00	OKGE	Cimarron 345kV
GEN-2012-016	312.00	OKGE	Tap Woodward - Thistle 345kV Ckt 1
GEN-2012-031	200.10	OKGE	Cimarron 345kV (GEN-2010-040 Sub)
GEN-2013-003	48.00	OKGE	Tap Woodwad - Thistle 345kV CKT (GEN-2012-016 Tap)
PRIOR QUEUED SUBTOTAL	5,495.90		
AREA TOTAL	5,495.90		

GROUP 2: HITCHLAND AREA			
Request	Capacity	Area	Proposed Point of Interconnection
ASGI-2011-002	10.00	SPS	Herring 115kV
GEN-2002-008	240.00	SPS	Hitchland 345kV
GEN-2002-009	80.00	SPS	Hansford 115kV
GEN-2003-020	160.00	SPS	Martin 115kV
GEN-2006-020S	18.90	SPS	DWS Frisco 115kV
GEN-2006-044	370.00	SPS	Hitchland 345kV
GEN-2007-046	199.50	SPS	Hitchland 115kV
GEN-2008-047	300.00	SPS	Tap Hitchland - Woodward Ckt 1 (Beaver County) 345kV
GEN-2008-124T	42.00	SPS	TC-Keyes Texas County 69kV
GEN-2010-001	300.00	SPS	Tap Hitchland - Woodward Ckt 1 (Beaver County) 345kV
GEN-2010-014	358.80	SPS	Hitchland 345kV
GEN-2011-012	104.50	SPS	Tap Moore County - Hitchland 345kV
GEN-2011-014	201.00	SPS	Tap Hitchland - Woodward Ckt 1 (Beaver County) 345kV
GEN-2011-021	299.00	SPS	Beaver County 345kV
GEN-2011-022	299.00	SPS	Hitchland 345kV
SPS Distributed (Dumas 19th St)	20.00	SPS	Dumas 19th Street 115kV
SPS Distributed (Etter)	20.00	SPS	Etter 115kV
SPS Distributed (Moore E)	25.00	SPS	Moore East 115kV
SPS Distributed (Sherman)	20.00	SPS	Sherman 115kV
SPS Distributed (Spearman)	10.00	SPS	Spearman 69kV
SPS Distributed (TC-Texas County)	20.00	SPS	Texas County 115kV
PRIOR QUEUED SUBTOTAL	3,097.70		
AREA TOTAL	3,097.70		

GROUP 3: SPEARVILLE AREA			
Request	Capacity	Area	Proposed Point of Interconnection
ASGI-2012-006	22.50	SUNCMKEC	Tap Hugoton - Rolla 69kV
GEN-2001-039A	105.00	SUNCMKEC	Tap Greensburg - Ft Dodge (Shooting Star Tap) 115kV
GEN-2002-025A	150.00	SUNCMKEC	Spearville 230kV
GEN-2004-014	154.50	SUNCMKEC	Spearville 230kV
GEN-2005-012	250.00	SUNCMKEC	Spearville 345kV
GEN-2006-006	205.50	SUNCMKEC	Spearville 345kV
GEN-2006-021	101.00	SUNCMKEC	Flat Ridge Tap 138kV
GEN-2006-022	150.00	SUNCMKEC	Ninnescah 115kV
GEN-2007-038	200.00	SUNCMKEC	Spearville 345kV
GEN-2007-040	200.00	SUNCMKEC	Buckner 345kV
GEN-2008-018	405.00	SPS	Finney 345kV
GEN-2008-079	98.90	SUNCMKEC	Tap Cudahy - Ft Dodge 115kV
GEN-2008-124	200.00	SUNCMKEC	Spearville 345kV
GEN-2010-009	165.60	SUNCMKEC	Buckner 345kV
GEN-2010-015	200.10	SUNCMKEC	Spearville 345kV
GEN-2010-045	197.80	SUNCMKEC	Buckner 345kV
GEN-2010-061	180.00	MIDW	Tap Post Rock - Spearville (GEN-2011-017T) 345kV
GEN-2011-008	600.00	SUNCMKEC	Clark County 345kV
GEN-2011-016	200.10	SUNCMKEC	Spearville 345kV
GEN-2011-017	299.00	SUNCMKEC	Tap Spearville - PostRock (GEN-2011-017T) 345kV
GEN-2011-023	299.00	SUNCMKEC	Clark County 345kV
GEN-2011-043	150.00	SUNCMKEC	Thistle 345kV
GEN-2011-044	150.00	SUNCMKEC	Thistle 345kV
GEN-2012-007	120.00	SUNCMKEC	Rubart 115kV
GEN-2012-011	200.00	SUNCMKEC	Tap Spearville - Post Rock 345kV (North of GEN-2011-017 Tap)
GEN-2012-024	180.00	SUNCMKEC	Clark County 345kV
GEN-2013-010	99.00	SUNCMKEC	Tap Spearville - Post Rock 345kV (GEN-2012-011 Tap)
Gray County Wind (Montezuma)	110.00	SUNCMKEC	Gray County Tap 115kV
PRIOR QUEUED SUBTOTAL	5,393.00		
AREA TOTAL	5,393.00		

GROUP 4: NW KANSAS AREA

Request	Capacity	Area	Proposed Point of Interconnection
GEN-2001-039M	99.00	SUNCMKEC	Central Plains Tap 115kV
GEN-2003-006A	200.00	SUNCMKEC	Elm Creek 230kV
GEN-2003-019	250.00	MIDW	Smoky Hills Tap 230kV
GEN-2006-031	75.00	MIDW	Knoll 115kV
GEN-2006-040	108.00	SUNCMKEC	Mingo 115kV
GEN-2007-011	135.00	SUNCMKEC	Syracuse 115kV
GEN-2008-017	300.00	SUNCMKEC	Setab 345kV
GEN-2008-092	201.00	MIDW	Knoll 230kV
GEN-2009-008	199.50	MIDW	South Hays 230kV
GEN-2009-020	48.60	MIDW	Tap Nekoma - Bazine 69kV
GEN-2010-048	70.00	MIDW	Tap Beach Station - Redline 115kV
GEN-2010-057	201.00	MIDW	Rice County 230kV
GEN-2012-002	101.20	SUNCMKEC	Tap Pile - Scott City 115kV
GEN-2012-026	100.00	MIDW	Colby 115kV
PRIOR QUEUED SUBTOTAL	2,088.30		
AREA TOTAL	2,088.30		

GROUP 5: AMARILLO AREA

Request	Capacity	Area	Proposed Point of Interconnection
ASGI-2013-001	12.78	SPS	PanTex South 115kV
GEN-2002-022	240.00	SPS	Bushland 230kV
GEN-2006-047	240.00	SPS	Tap Bushland - Deaf Smith (Buffalo) 230kV
GEN-2007-048	400.00	SPS	Tap Amarillo S - Swisher 230kV
GEN-2008-051	322.00	SPS	Potter County 345kV
GEN-2008-088	50.60	SPS	Vega 69kV
Llano Estacado (White Deer)	80.00	SPS	Llano Wind 115kV
PRIOR QUEUED SUBTOTAL	1,345.38		
AREA TOTAL	1,345.38		

GROUP 6: S-TX PANHANDLE/NW AREA			
Request	Capacity	Area	Proposed Point of Interconnection
ASGI-2010-010	42.20	SPS	Lovington 115kV
ASGI-2010-020	30.00	SPS	Tap LE-Tatum - LE-Crossroads 69kV
ASGI-2010-021	15.00	SPS	Tap LE-Saunders Tap - LE-Anderson 69kV
ASGI-2011-001	28.80	SPS	Lovington 115kV
ASGI-2011-003	10.00	SPS	Hendricks 115kV
ASGI-2011-004	20.00	SPS	Pleasant Hill 69kV
ASGI-2012-002	18.15	SPS	FE-Clovis Interchange 115kV
ASGI-2013-002	18.40	SPS	FE Tucumcari 115kV
ASGI-2013-003	18.40	SPS	FE Clovis 115kV
GEN-2001-033	180.00	SPS	San Juan Tap 230kV
GEN-2001-036	80.00	SPS	Norton 115kV
GEN-2006-018	170.00	SPS	TUCO Interchange 230kV
GEN-2006-026	604.00	SPS	Hobbs 230kV & Hobbs 115kV
GEN-2008-008	60.00	SPS	Graham 69kV
GEN-2008-009	60.00	SPS	San Juan Tap 230kV
GEN-2008-022	300.00	SPS	Tap Eddy Co - Tolk (Chaves County) 345kV
GEN-2010-006	205.00	SPS	Jones 230kV
GEN-2010-020	20.00	SPS	Roswell 69kV
GEN-2010-046	56.00	SPS	TUCO Interchange 230kV
GEN-2010-058	20.00	SPS	Chaves County 115kV
GEN-2011-025	82.30	SPS	Tap Floyd County - Crosby County 115kV
GEN-2011-045	205.00	SPS	Jones 230kV
GEN-2011-046	27.00	SPS	Lopez 115kV
GEN-2011-048	175.00	SPS	Mustang 230kV
GEN-2012-001	61.20	SPS	Tap Grassland - Borden County 230kV
GEN-2012-008	40.00	SPS	Mustang 115kV & Mustang 230kV
GEN-2012-009	15.00	SPS	Mustang 230kV
GEN-2012-010	15.00	SPS	Mustang 230kV
GEN-2012-020	477.12	SPS	TUCO 230kV
GEN-2012-034	7.00	SPS	Mustang 230kV
GEN-2012-035	7.00	SPS	Mustang 230kV
GEN-2012-036	7.00	SPS	Mustang 230kV
GEN-2012-037	203.00	SPS	TUCO 345kV
GEN-2013-013	248.40	SPS	Tap Eddy County - Tolk 345kV
GEN-2013-016	191.00	SPS	TUCO 345kV
GEN-2013-017	200.00	SPS	Tap TUCO - OKU 345kV
SPS Distributed (Hopi)	10.00	SPS	Hopi 115kV
SPS Distributed (Jal)	10.00	SPS	S Jal 115kV
SPS Distributed (Lea Road)	10.00	SPS	Lea Road 115kV
SPS Distributed (Monument)	10.00	SPS	Monument 115kV
SPS Distributed (Ocotillo)	10.00	SPS	Ocotillo 115kV
PRIOR QUEUED SUBTOTAL	3,966.97		
AREA TOTAL	3,967.0		

GROUP 7: SW OKLAHOMA AREA

Request	Capacity	Area	Proposed Point of Interconnection
GEN-2001-026	74.00	WFEC	Washita 138kV
GEN-2002-005	120.00	WFEC	Red Hills Tap 138kV
GEN-2003-004	100.00	WFEC	Washita 138kV
GEN-2003-005	100.00	WFEC	Anadarko - Paradise (Blue Canyon) 138kV
GEN-2003-022	120.00	AEPW	Washita 138kV
GEN-2004-020	27.00	AEPW	Washita 34.5kV
GEN-2004-023	20.60	WFEC	Washita 138kV
GEN-2005-003	30.60	WFEC	Washita 138kV
GEN-2006-002	101.00	AEPW	Sweetwater 230kV
GEN-2006-035	225.00	AEPW	Sweetwater 230kV
GEN-2006-043	99.00	AEPW	Sweetwater 230kV
GEN-2007-032	150.00	WFEC	Tap Clinton Junction - Clinton 138kV
GEN-2007-052	150.00	WFEC	Anadarko 138kV
GEN-2008-023	150.00	AEPW	Hobart Junction 138kV
GEN-2008-037	101.00	WFEC	Tap Washita - Blue Canyon Wind 138kV
GEN-2011-037	7.00	WFEC	Blue Canyon 5 138kV
GEN-2011-049	250.00	OKGE	Border 345kV
GEN-2012-028	74.80	WFEC	Gotebo 69kV
PRIOR QUEUED SUBTOTAL	1,900.00		
AREA TOTAL	1,900.00		

GROUP 8: N-OK/S-KS AREA

Request	Capacity	Area	Proposed Point of Interconnection
ASGI-2010-006	150.00	AECI	Tap Fairfax (AECI) - Shilder (AEPW) 138kV
GEN-2002-004	200.00	WERE	Latham 345kV
GEN-2005-013	201.00	WERE	Tap Latham - Neosho (Caney River) 345kV
GEN-2007-025	300.00	WERE	Viola 345kV
GEN-2008-013	300.00	OKGE	Tap Wichita - Woodring (Hunter) 345kV
GEN-2008-021	42.00	WERE	Wolf Creek 345kV
GEN-2008-071	76.80	OKGE	Newkirk 138kV
GEN-2008-098	100.80	WERE	Tap Lacygne - Wolf Creek (Anderson County) 345kV
GEN-2009-025	60.00	OKGE	Tap Deer Creek - Sinclair Blackwell 69kV
GEN-2010-003	100.80	WERE	Tap Lacygne - Wolf Creek (Anderson County) 345kV
GEN-2010-005	300.00	WERE	Viola 345kV
GEN-2010-055	4.50	AEPW	Wekiwa 138kV
GEN-2011-057	150.40	WERE	Creswell 138kV
GEN-2012-023	115.00	WERE	Viola 345kV
GEN-2012-027	136.00	AEPW	Shidler 138kV
GEN-2012-032	300.00	OKGE	Tap Rose Hill - Sooner 345kV
GEN-2012-033	98.82	OKGE	Tap and Tie South 4th - Bunch Creek & Enid Tap - Fairmont (GEN-2012-033T) 138kV
GEN-2012-040	76.50	WFEC	Newkirk 138kV
GEN-2012-041	121.50	OKGE	Tap Rose Hill - Sooner 345kV
GEN-2013-009	100.30	AEPW	Tap Alluwe Tap - Vinita Junction 138kV
GEN-2013-012	147.00	OKGE	Redbud 345kV
PRIOR QUEUED SUBTOTAL	3,081.42		
GEN-2013-020	200.10	WERE	Florence Jct 115kV or Tap Wichita - Emporia Energy Center 345kV
CURRENT CLUSTER SUBTOTAL	200.10		
AREA TOTAL	3,281.5		

GROUP 9/10: NEBRASKA AREA			
Request	Capacity	Area	Proposed Point of Interconnection
GEN-2002-023N	0.80	NPPD	Harmony 115kV
GEN-2003-021N	75.00	NPPD	Ainsworth Wind Tap 115kV
GEN-2004-005N	30.00	NPPD	St Francis 115kV
GEN-2004-023N	75.00	NPPD	Columbus Co 115kV
GEN-2006-020N	42.00	NPPD	Bloomfield 115kV
GEN-2006-037N1	75.00	NPPD	Broken Bow 115kV
GEN-2006-038N005	80.00	NPPD	Broken Bow 115kV
GEN-2006-038N019	80.00	NPPD	Petersburg North 115kV
GEN-2006-044N	40.50	OPPD	North Petersburg 115kV
GEN-2007-011N08	81.00	NPPD	Bloomfield 115kV
GEN-2008-086N02	200.00	NPPD	Tap Ft Randle - Columbus (Madison County) 230kV
GEN-2008-1190	60.00	OPPD	S1399 161kV
GEN-2008-123N	89.70	NPPD	Tap Guide Rock - Pauline 115kV
GEN-2009-040	73.80	WERE	Marshall 115kV
GEN-2010-041	10.50	OPPD	S 1399 161kV
GEN-2010-044	99.00	NPPD	Harbine 115kV
GEN-2010-051	200.00	NPPD	Tap Twin Church - Hoskins 230kV
GEN-2011-018	73.60	NPPD	Steele City 115kV
GEN-2011-027	120.00	NPPD	Hoskins 230kV
GEN-2011-055	52.80	OPPD	South Sterling 69kV
GEN-2011-056	3.60	NPPD	Jeffrey 115kV
GEN-2011-056A	3.60	NPPD	John 1 115kV
GEN-2011-056B	4.50	NPPD	John 2 115kV
GEN-2012-005	81.00	NPPD	Tap Fort Randall - Columbus (North of Madison Co) 230kV
GEN-2012-017	115.00	NPPD	Cooper 345kV
GEN-2012-018	200.00	NPPD	Tap Hoskins - Twin Church 230kV (GEN-2010-051T)
GEN-2012-021	4.80	LES	Terry Bundy Generating Station 115kV
GEN-2013-002	50.60	LES	Tap Sheldon - Folsom 115kV CKT 1
GEN-2013-004	6.00	NPPD	Tap Fort Randall - Columbus (Madison County)
GEN-2013-005	73.50	NPPD	Madison County (GEN-2008-086N2 Sub)
GEN-2013-006	50.60	NPPD	Tap Fort Randall - Columbus (Madison County)
GEN-2013-008	1.20	NPPD	Steele City 115kV
GEN-2013-014	25.50	NPPD	Tap Guide Rock - Pauline (GEN-2008-123N Tap) 115kV
GEN-2013-015	125.80	NPPD	Tap Pauline - Hildreth 115kV
GEN-2013-018	51.00	OPPD	Tap S974 - Hydrocarbon Tap 69kV
NPPD Distributed (Broken Bow)	8.30	NPPD	Broken Bow 115kV
NPPD Distributed (Burwell)	3.00	NPPD	Ord 115kV
NPPD Distributed (Columbus Hydro)	45.00	NPPD	Columbus 115kV
NPPD Distributed (North Platte - Lexington)	54.00	NPPD	Multiple: Jeffrey 115kV, John_1 115kV, John_2 115kV
NPPD Distributed (Ord)	10.80	NPPD	Ord 115kV
NPPD Distributed (Stuart)	2.10	NPPD	Ainsworth 115kV
PRIOR QUEUED SUBTOTAL	2,478.60		
AREA TOTAL	2,478.6		

GROUP 12: NW AR AREA			
Request	Capacity	Area	Proposed Point of Interconnection
GEN-2006-010	620.00	AEPW	Turk 138kV
GEN-2013-011	30.00	AEPW	Turk 138kV
PRIOR QUEUED SUBTOTAL	650.00		
AREA TOTAL	650.00		

GROUP 13: NW MISSOURI AREA			
Request	Capacity	Area	Proposed Point of Interconnection
GEN-2008-129	80.00	MIPU	Pleasant Hill 161kV
GEN-2010-036	4.60	WERE	6th Street 115kV
GEN-2010-056	151.20	MIPU	Tap Saint Joseph - Cooper 345kV
GEN-2011-011	50.00	KACP	Iatan 345kV
PRIOR QUEUED SUBTOTAL	285.80		
AREA TOTAL	285.80		

GROUP 14: S OKLAHOMA AREA			
Request	Capacity	Area	Proposed Point of Interconnection
GEN-2011-040	111.00	OKGE	Tap Ratliff - Pooleville 138kV
GEN-2011-050	109.80	AEPW	Tap Rush Springs - Marlow 138kV
GEN-2012-004	41.40	OKGE	Tap Ratliff - Pooleville 138kV
GEN-2013-007	100.30	OKGE	Tap Prices Falls - Carter 138kV
PRIOR QUEUED SUBTOTAL	362.50		
AREA TOTAL	362.50		

CLUSTER TOTAL (CURRENT STUDY)	200.1	MW
PQ TOTAL (PRIOR QUEUED)	30,145.6	MW
CLUSTER TOTAL (INCLUDING PRIOR QUEUED)	30,345.7	MW

D: Proposed Point of Interconnection One line Diagrams

GEN-2013-020-115kV

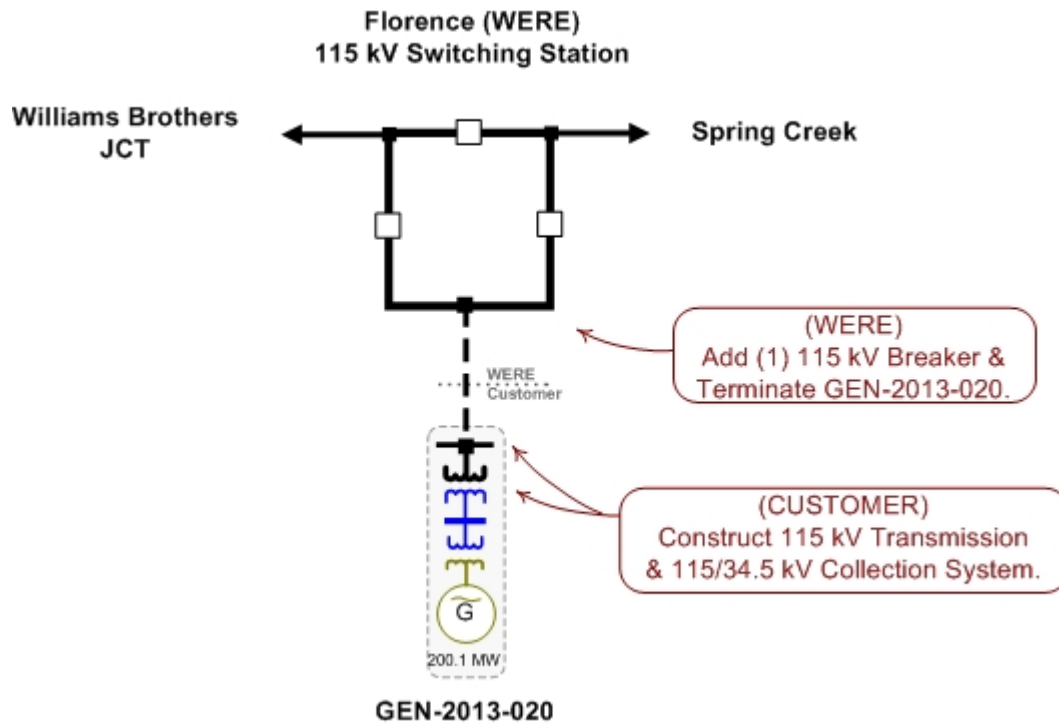

GEN-2013-020-345kV

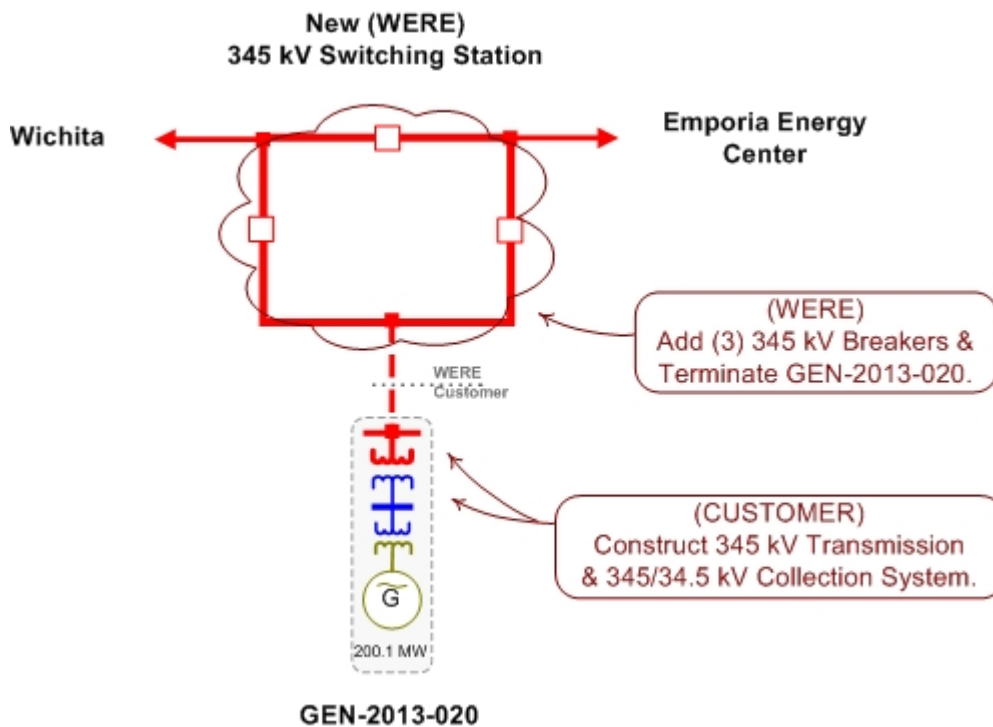

E: Cost Allocation per Interconnection Request (Including Prior Queued Upgrades)

Important Note:

****WITHDRAWAL OF HIGHER QUEUED PROJECTS WILL CAUSE A RESTUDY AND MAY RESULT IN HIGHER INTERCONNECTION COSTS****

This section shows each Generation Interconnection Request Customer, their current study impacted Network Upgrades, and the previously allocated upgrades upon which they rely to accommodate their interconnection to the transmission system.

The costs associated with the current study Network Upgrades are allocated to the Customers shown in this report.

In addition should a higher queued request, defined as one this study includes as a prior queued request, withdraw, the Network Upgrades assigned to the withdrawn request may be reallocated to the remaining requests that have an impact on the Network Upgrade under a restudy. Also, should a Interconnection Request choose to go into service prior to the operation date of any necessary Network Upgrades, the costs associated with those upgrades may be reallocated to the impacted Interconnection Request. The actual costs allocated to each Generation Interconnection Request Customer will be determined at the time of a restudy.

The required interconnection costs listed do not include all costs associated with the deliverability of the energy to final customers. These costs are determined by separate studies if the Customer submits a Transmission Service Request through SPP's Open Access Same Time Information System (OASIS) as required by Attachment Z1 of the SPP OATT. In addition, costs associated with a short circuit analysis will be allocated should the Interconnection Request Customer choose to execute a Facility Study Agreement.

Appendix E. Cost Allocation Per Request

(Including Previously Allocated Network Upgrades*)

Interconnection Request and Upgrades	Upgrade Type	Allocated Cost	Upgrade Cost
GEN-2013-020-115kV (Option 1)			
Florence - Spring Creek 115kV CKT 1 Rebuild approximately 10 miles of 115kV transmission lines	Current Study	\$8,080,000.00	\$8,080,000.00
Florence - Williams Brothers Pipeline Co 115kV CKT 1 Rebuild approximately 41 miles of 115kV transmission lines	Current Study	\$32,880,000.00	\$32,880,000.00
GEN-2013-020 Interconnection Costs (115kV) See One-Line Diagram.	Current Study	\$5,315,000.00	\$5,315,000.00
Moundridge - Spring Creek 115kV CKT 1 Rebuild approximately 19 miles of 115kV transmission lines	Current Study	\$15,200,000.00	\$15,200,000.00
Moundridge - Yost 69kV CKT 1 NRIS only required upgrade: Rebuild approximately 5.5 miles of 69kV transmission lines	Current Study	\$2,600,000.00	\$2,600,000.00
West Emporia - Williams Brothers Pipeline Co 115kV CKT 1 Rebuild approximately 4.5 miles of 115kV transmission lines	Current Study	\$3,600,000.00	\$3,600,000.00
Arcadia - Kamo Memorial 138kV CKT 1 NRIS Upgrade Only: Rebuild approximately 7 miles of 138kV	Previously Allocated		\$7,000,000.00
Catoosa - Terra Nitrogen Tap 138kV CKT 1 NRIS Upgrade Only: Rebuild approximately 6 miles of 138kV	Previously Allocated		\$6,000,000.00
Chisholm - Maize East 138kV CKT 1 NRIS only required upgrade: Rebuild approximately 6 miles of 138kV	Previously Allocated		\$10,060,000.00
Cleveland - Sooner 345KV CKT 1 Balanced Portfolio: Cleveland - Sooner 345kV CKT 1 (Total Project E&C Cost Shown).	Previously Allocated		\$58,692,000.00
Evans Energy Center - Maize West 138kV CKT 1 NRIS only required upgrade: Rebuild approximately 2.6 miles of 138kV	Previously Allocated		\$4,186,000.00
Fairfax 138/69kV CKT 1 Per AECL Affected System Study for DISIS-2012-002	Previously Allocated		\$2,200,000.00
Mound Ridge 138/115/13.8kV Transformer CKT 2 Install 2nd 115/138kV transformer at Mound ridge substation	Previously Allocated		\$12,197,900.00
Remington - Fairfax 138KV CKT 1 Increase conductor clearance	Previously Allocated		\$400,000.00

* Withdrawal of higher queued projects will cause a restudy and may result in higher costs

Interconnection Request and Upgrades	Upgrade Type	Allocated Cost	Upgrade Cost
Terra Nitrogen Tap - Verdigras 138kV CKT 1 NRIS Upgrade Only: Rebuild approximately 4 miles of 138kV	Previously Allocated		\$4,000,000.00
Vinita - Vinita Junction 69kV CKT 1 Rebuild approximately 3 miles of 69kV	Previously Allocated		\$2,100,000.00
	Current Study Total	\$67,675,000.00	
GEN-2013-020-345kV (Option 2)			
GEN-2013-020 Interconnection Costs (345kV) See One-Line Diagram.	Current Study	\$14,800,000.00	\$14,800,000.00
Wichita 345/138/13.8kV Transformer CKT 3 NRIS only required upgrade: Build Wichita 345/138/13.8kV transformer CKT 3	Current Study	\$15,000,000.00	\$15,000,000.00
Arcadia - Kamo Memorial 138kV CKT 1 NRIS Upgrade Only: Rebuild approximately 7 miles of 138kV	Previously Allocated		\$7,000,000.00
Catoosa - Terra Nitrogen Tap 138kV CKT 1 NRIS Upgrade Only: Rebuild approximately 6 miles of 138kV	Previously Allocated		\$6,000,000.00
Chisholm - Maize East 138kV CKT 1 NRIS only required upgrade: Rebuild approximately 6 miles of 138kV	Previously Allocated		\$10,060,000.00
Cleveland - Sooner 345KV CKT 1 Balanced Portfolio: Cleveland - Sooner 345kV CKT 1 (Total Project E&C Cost Shown).	Previously Allocated		\$58,692,000.00
Evans Energy Center - Maize West 138kV CKT 1 NRIS only required upgrade: Rebuild approximately 2.6 miles of 138kV	Previously Allocated		\$4,186,000.00
Fairfax 138/69kV CKT 1 Per AECL Affected System Study for DISIS-2012-002	Previously Allocated		\$2,200,000.00
Remington - Fairfax 138KV CKT 1 Increase conductor clearance	Previously Allocated		\$400,000.00
Terra Nitrogen Tap - Verdigras 138kV CKT 1 NRIS Upgrade Only: Rebuild approximately 4 miles of 138kV	Previously Allocated		\$4,000,000.00
Vinita - Vinita Junction 69kV CKT 1 Rebuild approximately 3 miles of 69kV	Previously Allocated		\$2,100,000.00
	Current Study Total	\$29,800,000.00	

* Withdrawal of higher queued projects will cause a restudy and may result in higher costs

F: Cost Allocation per Proposed Study Network Upgrade

Important Note:

****WITHDRAWAL OF HIGHER QUEUED PROJECTS WILL CAUSE A RESTUDY
AND MAY RESULT IN HIGHER INTERCONNECTION COSTS****

This section shows each Direct Assigned Facility and Network Upgrade and the Generation Interconnection Request Customer(s) which have an impact in this study assuming all higher queued projects remain in the queue and achieve commercial operation.

The required interconnection costs listed do not include all costs associated with the deliverability of the energy to final customers. These costs are determined by separate studies if the Customer submits a Transmission Service Request through SPP's Open Access Same Time Information System (OASIS) as required by Attachment Z1 of the SPP OATT. In addition, costs associated with a short circuit analysis will be allocated should the Interconnection Request Customer choose to execute a Facility Study Agreement.

There may be additional costs allocated to each Customer. See Appendix E for more details.

G: FCITC Analysis Constraints Requiring Mitigation (ERIS)

SEASON	GROUP	SCENARIO	DIRECTION	SOURCE	MONITORED ELEMENT	RATE (MVA)	TDF	CONTINGENCY LOADING %	CONTINGENCY
N/A	N/A	N/A	N/A	G13_020_345	N/A	N/A	N/A	N/A	N/A

H: FCITC Analysis Constraints Requiring Mitigation (NRIS)

SEASON	GROUP	SCENARIO	DIRECTION	SOURCE	MONITORED ELEMENT	RATE (MVA)	TDF	CONTINGENCY LOADING %	CONTINGENCY
13SP	00G13_020NR	0	TO->FROM	G13_020_115	WEST EMPORIA - WILLIAMS BROTHERS PIPELINE COMPANY JUNCTION 115KV CKT 1	79.9	0.42332	112.5056	JEFFERY ENERGY CENTER 345/26.0KV TRANSFORMER CKT 1
13SP	00G13_020NR	0	TO->FROM	G13_020_115	WEST EMPORIA - WILLIAMS BROTHERS PIPELINE COMPANY JUNCTION 115KV CKT 1	79.9	0.42332	112.5056	JEFFERY ENERGY CENTER 345/26.0KV TRANSFORMER CKT 1
18SP	00G13_020NR	0	TO->FROM	G13_020_115	WEST EMPORIA - WILLIAMS BROTHERS PIPELINE COMPANY JUNCTION 115KV CKT 1	80	0.41844	112.11	IATAN 345/25.0KV TRANSFORMER CKT 1
13SP	00G13_020NR	0	TO->FROM	G13_020_115	WEST EMPORIA - WILLIAMS BROTHERS PIPELINE COMPANY JUNCTION 115KV CKT 1	79.9	0.42456	112.03	EMPORIA ENERGY CENTER - WICHITA 345KV CKT 1
23SP	00G13_020NR	0	TO->FROM	G13_020_115	WEST EMPORIA - WILLIAMS BROTHERS PIPELINE COMPANY JUNCTION 115KV CKT 1	79.9	0.41791	111.9925	IATAN 345/24.0KV TRANSFORMER CKT 1
13SP	00G13_020NR	0	TO->FROM	G13_020_115	WEST EMPORIA - WILLIAMS BROTHERS PIPELINE COMPANY JUNCTION 115KV CKT 1	79.9	0.42332	111.97	HILLSBORO - SPRING CREEK JUNCTION 115KV CKT 1
23SP	00G13_020NR	0	TO->FROM	G13_020_115	WEST EMPORIA - WILLIAMS BROTHERS PIPELINE COMPANY JUNCTION 115KV CKT 1	79.9	0.42032	111.97	RENO COUNTY - SUMMIT 345KV CKT 1
23SP	00G13_020NR	0	TO->FROM	G13_020_115	WEST EMPORIA - WILLIAMS BROTHERS PIPELINE COMPANY JUNCTION 115KV CKT 1	79.9	0.41801	111.6421	LACYGNE - STILWELL 345KV CKT 1
23SP	00G13_020NR	0	TO->FROM	G13_020_115	WEST EMPORIA - WILLIAMS BROTHERS PIPELINE COMPANY JUNCTION 115KV CKT 1	79.9	0.41791	111.5044	LAWRENCE ENERGY CENTER UNIT 5 - LAWRENCE HILL 230KV CKT 1
23SP	00G13_020NR	0	TO->FROM	G13_020_115	WEST EMPORIA - WILLIAMS BROTHERS PIPELINE COMPANY JUNCTION 115KV CKT 1	79.9	0.41791	111.5044	LAWRENCE ENERGY CENTER UNIT 5 230/24.0KV TRANSFORMER CKT 1
13SP	00G13_020NR	0	TO->FROM	G13_020_115	WEST EMPORIA - WILLIAMS BROTHERS PIPELINE COMPANY JUNCTION 115KV CKT 1	79.9	0.42332	111.219	IATAN 345/25.0KV TRANSFORMER CKT 1
23SP	00G13_020NR	0	TO->FROM	G13_020_115	WEST EMPORIA - WILLIAMS BROTHERS PIPELINE COMPANY JUNCTION 115KV CKT 1	79.9	0.40343	111.1214	MORRIS COUNTY (MORRIS2X) 230/115/13.8KV TRANSFORMER CKT 1
18SP	00G13_020NR	0	TO->FROM	G13_020_115	WEST EMPORIA - WILLIAMS BROTHERS PIPELINE COMPANY JUNCTION 115KV CKT 1	80	0.41844	110.735	IATAN 345/24.0KV TRANSFORMER CKT 1
18SP	00G13_020NR	0	TO->FROM	G13_020_115	WEST EMPORIA - WILLIAMS BROTHERS PIPELINE COMPANY JUNCTION 115KV CKT 1	80	0.41856	110.14	LACYGNE - STILWELL 345KV CKT 1
18SP	00G13_020NR	0	TO->FROM	G13_020_115	WEST EMPORIA - WILLIAMS BROTHERS PIPELINE COMPANY JUNCTION 115KV CKT 1	80	0.41844	110	LAWRENCE ENERGY CENTER UNIT 5 - LAWRENCE HILL 230KV CKT 1
18SP	00G13_020NR	0	TO->FROM	G13_020_115	WEST EMPORIA - WILLIAMS BROTHERS PIPELINE COMPANY JUNCTION 115KV CKT 1	80	0.41844	110	LAWRENCE ENERGY CENTER UNIT 5 230/24.0KV TRANSFORMER CKT 1
13SP	00G13_020NR	0	TO->FROM	G13_020_115	WEST EMPORIA - WILLIAMS BROTHERS PIPELINE COMPANY JUNCTION 115KV CKT 1	79.9	0.42332	109.9675	IATAN 345/24.0KV TRANSFORMER CKT 1
18SP	00G13_020NR	0	TO->FROM	G13_020_115	WEST EMPORIA - WILLIAMS BROTHERS PIPELINE COMPANY JUNCTION 115KV CKT 1	80	0.40392	109.855	MORRIS COUNTY (MORRIS2X) 230/115/13.8KV TRANSFORMER CKT 1
13SP	00G13_020NR	0	TO->FROM	G13_020_115	WEST EMPORIA - WILLIAMS BROTHERS PIPELINE COMPANY JUNCTION 115KV CKT 1	79.9	0.42388	109.3567	RENO COUNTY - WICHITA 345KV CKT 1
13G	08G13_020NR	0	TO->FROM	G13_020_115	WEST EMPORIA - WILLIAMS BROTHERS PIPELINE COMPANY JUNCTION 115KV CKT 1	79.9	0.42845	109.2491	ANDERSONCO 345.00 - LACYGNE 345KV CKT 1
13SP	00G13_020NR	0	TO->FROM	G13_020_115	WEST EMPORIA - WILLIAMS BROTHERS PIPELINE COMPANY JUNCTION 115KV CKT 1	79.9	0.42332	109.204	LAWRENCE ENERGY CENTER UNIT 5 230/24.0KV TRANSFORMER CKT 1
13SP	00G13_020NR	0	TO->FROM	G13_020_115	WEST EMPORIA - WILLIAMS BROTHERS PIPELINE COMPANY JUNCTION 115KV CKT 1	79.9	0.40865	109.0488	MORRIS COUNTY (MORRIS2X) 230/115/13.8KV TRANSFORMER CKT 1
13G	08G13_020NR	0	TO->FROM	G13_020_115	WEST EMPORIA - WILLIAMS BROTHERS PIPELINE COMPANY JUNCTION 115KV CKT 1	79.9	0.42845	106.2453	ANDERSONCO 345.00 - WOLF CREEK 345KV CKT 1
13G	08G13_020NR	0	TO->FROM	G13_020_115	WEST EMPORIA - WILLIAMS BROTHERS PIPELINE COMPANY JUNCTION 115KV CKT 1	79.9	0.45529	106.2053	HALSTEAD NORTH BUS - MOUNDRIDGE 138KV CKT 1
13G	08G13_020NR	0	TO->FROM	G13_020_115	WEST EMPORIA - WILLIAMS BROTHERS PIPELINE COMPANY JUNCTION 115KV CKT 1	79.9	0.38245	105.7447	EMPORIA ENERGY CENTER - LANG 345KV CKT 1
13G	08G13_020NR	0	TO->FROM	G13_020_115	WEST EMPORIA - WILLIAMS BROTHERS PIPELINE COMPANY JUNCTION 115KV CKT 1	79.9	0.38245	105.6195	LANG (LANG 1X) 345/115/14.4KV TRANSFORMER CKT 1
13G	08G13_020NR	0	TO->FROM	G13_020_115	WEST EMPORIA - WILLIAMS BROTHERS PIPELINE COMPANY JUNCTION 115KV CKT 1	79.9	0.42743	105.0388	JEFFERY ENERGY CENTER 230/26.0KV TRANSFORMER CKT 1
13G	08G13_020NR	0	TO->FROM	G13_020_115	WEST EMPORIA - WILLIAMS BROTHERS PIPELINE COMPANY JUNCTION 115KV CKT 1	79.9	0.42743	104.6959	JEFFERY ENERGY CENTER 345/26.0KV TRANSFORMER CKT 1
13G	08G13_020NR	0	TO->FROM	G13_020_115	WEST EMPORIA - WILLIAMS BROTHERS PIPELINE COMPANY JUNCTION 115KV CKT 1	79.9	0.42338	104.1001	JEFFERY ENERGY CENTER - MORRIS COUNTY 345KV CKT 1
13G	08G13_020NR	0	TO->FROM	G13_020_115	WEST EMPORIA - WILLIAMS BROTHERS PIPELINE COMPANY JUNCTION 115KV CKT 1	79.9	0.42743	102.6808	JEFFERY ENERGY CENTER 345/26.0KV TRANSFORMER CKT 1
13G	08G13_020NR	0	TO->FROM	G13_020_115	WEST EMPORIA - WILLIAMS BROTHERS PIPELINE COMPANY JUNCTION 115KV CKT 1	79.9	0.42743	101.7347	HILLSBORO - SPRING CREEK JUNCTION 115KV CKT 1
13G	08G13_020NR	0	TO->FROM	G13_020_115	WEST EMPORIA - WILLIAMS BROTHERS PIPELINE COMPANY JUNCTION 115KV CKT 1	79.9	0.42743	101.6095	IATAN 345/25.0KV TRANSFORMER CKT 1
13G	08G13_020NR	0	TO->FROM	G13_020_115	WEST EMPORIA - WILLIAMS BROTHERS PIPELINE COMPANY JUNCTION 115KV CKT 1	79.9	0.42743	101.5244	LAWRENCE ENERGY CENTER UNIT 5 - LAWRENCE HILL 230KV CKT 1
13G	08G13_020NR	0	TO->FROM	G13_020_115	WEST EMPORIA - WILLIAMS BROTHERS PIPELINE COMPANY JUNCTION 115KV CKT 1	79.9	0.42743	101.5244	LAWRENCE ENERGY CENTER UNIT 5 230/24.0KV TRANSFORMER CKT 1
13G	08G13_020NR	0	TO->FROM	G13_020_115	WEST EMPORIA - WILLIAMS BROTHERS PIPELINE COMPANY JUNCTION 115KV CKT 1	79.9	0.42767	101.4193	LACYGNE - STILWELL 345KV CKT 1
13G	08G13_020NR	0	TO->FROM	G13_020_115	WEST EMPORIA - WILLIAMS BROTHERS PIPELINE COMPANY JUNCTION 115KV CKT 1	79.9	0.43044	101.1114	EMPORIA ENERGY CENTER - WICHITA 345KV CKT 1
13G	08G13_020NR	0	TO->FROM	G13_020_115	WEST EMPORIA - WILLIAMS BROTHERS PIPELINE COMPANY JUNCTION 115KV CKT 1	79.9	0.42774	100.811	LACYGNE - WEST GARDNER 345KV CKT 1

SEASON	GROUP	SCENARIO	DIRECTION	SOURCE	MONITORED ELEMENT	RATE (MVA)	TDF	CONTINGENCY LOADING %	CONTINGENCY
23SP	00G13_020NR	0	TO->FROM	G13_020_345	CHISHOLM - MAIZEE 4 138.00 138KV CKT 1	381.9	0.03341	112.1713	BENTON - WICHITA 345KV CKT 1
18SP	00G13_020NR	0	TO->FROM	G13_020_345	CHISHOLM - MAIZEE 4 138.00 138KV CKT 1	381.7	0.03283	104.0519	BENTON - WICHITA 345KV CKT 1
13SP	00G13_020NR	0	TO->FROM	G13_020_345	CHISHOLM - MAIZEE 4 138.00 138KV CKT 1	382	0.03683	102.5042	BENTON - WICHITA 345KV CKT 1
23SP	00G13_020NR	0	FROM->TO	G13_020_345	EVANS ENERGY CENTER NORTH - MAIZEW 4 138.00 138KV CKT 1	381.4	0.03341	118.1914	BENTON - WICHITA 345KV CKT 1
18SP	00G13_020NR	0	FROM->TO	G13_020_345	EVANS ENERGY CENTER NORTH - MAIZEW 4 138.00 138KV CKT 1	381.9	0.03283	109.1558	BENTON - WICHITA 345KV CKT 1
13SP	00G13_020NR	0	FROM->TO	G13_020_345	EVANS ENERGY CENTER NORTH - MAIZEW 4 138.00 138KV CKT 1	381.5	0.03683	107.2257	BENTON - WICHITA 345KV CKT 1
13SP	00G13_020NR	0	FROM->TO	G13_020_345	WICHITA (WICHT11X) 345/138/13.8KV TRANSFORMER CKT 1	436.7	0.10511	106.8289	WICHITA (WICHT12X) 345/138/13.8KV TRANSFORMER CKT 1
13SP	00G13_020NR	0	FROM->TO	G13_020_345	WICHITA (WICHT11X) 345/138/13.8KV TRANSFORMER CKT 1	439	0.10511	106.1326	WICHITA (WICHT12X) 345/138/13.8KV TRANSFORMER CKT 1
13G	08G13_020NR	0	FROM->TO	G13_020_345	WICHITA (WICHT11X) 345/138/13.8KV TRANSFORMER CKT 1	431.6	0.04435	104.2099	WICHITA (WICHT12X) 345/138/13.8KV TRANSFORMER CKT 1
18WP	00G13_020NR	0	FROM->TO	G13_020_345	WICHITA (WICHT11X) 345/138/13.8KV TRANSFORMER CKT 1	432.9	0.0473	103.6868	WICHITA (WICHT12X) 345/138/13.8KV TRANSFORMER CKT 1
13G	08G13_020NR	0	FROM->TO	G13_020_345	WICHITA (WICHT11X) 345/138/13.8KV TRANSFORMER CKT 1	435.6	0.04435	103.1152	WICHITA (WICHT12X) 345/138/13.8KV TRANSFORMER CKT 1
18WP	00G13_020NR	0	FROM->TO	G13_020_345	WICHITA (WICHT11X) 345/138/13.8KV TRANSFORMER CKT 1	436.7	0.0473	102.6242	WICHITA (WICHT12X) 345/138/13.8KV TRANSFORMER CKT 1
13WP	00G13_020NR	0	FROM->TO	G13_020_345	WICHITA (WICHT11X) 345/138/13.8KV TRANSFORMER CKT 1	434.3	0.04726	101.2554	WICHITA (WICHT12X) 345/138/13.8KV TRANSFORMER CKT 1
13WP	00G13_020NR	0	FROM->TO	G13_020_345	WICHITA (WICHT11X) 345/138/13.8KV TRANSFORMER CKT 1	437.5	0.04726	100.3547	WICHITA (WICHT12X) 345/138/13.8KV TRANSFORMER CKT 1
13SP	00G13_020NR	0	FROM->TO	G13_020_345	WICHITA (WICHT12X) 345/138/13.8KV TRANSFORMER CKT 1	435.4	0.11183	113.9793	WICHITA (WICHT11X) 345/138/13.8KV TRANSFORMER CKT 1
13SP	00G13_020NR	0	FROM->TO	G13_020_345	WICHITA (WICHT12X) 345/138/13.8KV TRANSFORMER CKT 1	438.5	0.11183	113.0367	WICHITA (WICHT11X) 345/138/13.8KV TRANSFORMER CKT 1
13G	08G13_020NR	0	FROM->TO	G13_020_345	WICHITA (WICHT12X) 345/138/13.8KV TRANSFORMER CKT 1	428.6	0.04717	111.5572	WICHITA (WICHT11X) 345/138/13.8KV TRANSFORMER CKT 1
18WP	00G13_020NR	0	FROM->TO	G13_020_345	WICHITA (WICHT12X) 345/138/13.8KV TRANSFORMER CKT 1	430.3	0.05036	111.0091	WICHITA (WICHT11X) 345/138/13.8KV TRANSFORMER CKT 1
13G	08G13_020NR	0	FROM->TO	G13_020_345	WICHITA (WICHT12X) 345/138/13.8KV TRANSFORMER CKT 1	434	0.04717	110.0309	WICHITA (WICHT11X) 345/138/13.8KV TRANSFORMER CKT 1
18WP	00G13_020NR	0	FROM->TO	G13_020_345	WICHITA (WICHT12X) 345/138/13.8KV TRANSFORMER CKT 1	435.5	0.05036	109.5458	WICHITA (WICHT11X) 345/138/13.8KV TRANSFORMER CKT 1
13SP	00G13_020NR	0	FROM->TO	G13_020_345	WICHITA (WICHT12X) 345/138/13.8KV TRANSFORMER CKT 1	435.4	0.10854	108.7524	BENTON - WICHITA 345KV CKT 1
13WP	00G13_020NR	0	FROM->TO	G13_020_345	WICHITA (WICHT12X) 345/138/13.8KV TRANSFORMER CKT 1	432.1	0.05031	108.2763	WICHITA (WICHT11X) 345/138/13.8KV TRANSFORMER CKT 1
13SP	00G13_020NR	0	FROM->TO	G13_020_345	WICHITA (WICHT12X) 345/138/13.8KV TRANSFORMER CKT 1	438.5	0.10854	107.8696	BENTON - WICHITA 345KV CKT 1
13WP	00G13_020NR	0	FROM->TO	G13_020_345	WICHITA (WICHT12X) 345/138/13.8KV TRANSFORMER CKT 1	436.5	0.05031	107.0474	WICHITA (WICHT11X) 345/138/13.8KV TRANSFORMER CKT 1
18WP	00G13_020NR	0	FROM->TO	G13_020_345	WICHITA (WICHT12X) 345/138/13.8KV TRANSFORMER CKT 1	430.3	0.06984	103.6412	BENTON - WICHITA 345KV CKT 1
18WP	00G13_020NR	0	FROM->TO	G13_020_345	WICHITA (WICHT12X) 345/138/13.8KV TRANSFORMER CKT 1	435.5	0.06984	102.2659	BENTON - WICHITA 345KV CKT 1
13WP	00G13_020NR	0	FROM->TO	G13_020_345	WICHITA (WICHT12X) 345/138/13.8KV TRANSFORMER CKT 1	432.1	0.07017	101.489	BENTON - WICHITA 345KV CKT 1
13SP	00G13_020NR	0	FROM->TO	G13_020_345	WICHITA (WICHT12X) 345/138/13.8KV TRANSFORMER CKT 1	435.4	0.07452	100.4212	EVANS ENERGY CENTER NORTH 138/24.0KV TRANSFORMER CKT 1
13WP	00G13_020NR	0	FROM->TO	G13_020_345	WICHITA (WICHT12X) 345/138/13.8KV TRANSFORMER CKT 1	436.5	0.07017	100.3514	BENTON - WICHITA 345KV CKT 1

I: FCITC Analysis Constraints Not Requiring Transmission Reinforcement

SEASON	GROUP	SCENARIO	DIRECTION	SOURCE	MONITORED ELEMENT	RATE (MVA)	TDF	CONTINGENCY LOADING %	CONTINGENCY
13G	08ALL	0	TO->FROM	G13_020_115	WEST EMPORIA - WILLIAMS BROTHERS PIPELINE COMPANY JUNCTION 115KV	80	0.46272	117.055	MOUNDRIDGE (MOUND10X) 138/115/13.8KV TRANSFORMER CKT 1
13G	08ALL	0	TO->FROM	G13_020_115	WEST EMPORIA - WILLIAMS BROTHERS PIPELINE COMPANY JUNCTION 115KV	80	0.41761	109.7775	ANDERSONCO 345.00 - LACYGNE 345KV CKT 1
13G	08ALL	0	TO->FROM	G13_020_115	WEST EMPORIA - WILLIAMS BROTHERS PIPELINE COMPANY JUNCTION 115KV	80	0.41761	106.1525	ANDERSONCO 345.00 - WOLF CREEK 345KV CKT 1
13G	08ALL	0	TO->FROM	G13_020_115	WEST EMPORIA - WILLIAMS BROTHERS PIPELINE COMPANY JUNCTION 115KV	80	0.44667	105.4175	HALSTEAD NORTH BUS - MOUNDRIDGE 138KV CKT 1
13G	08ALL	0	TO->FROM	G13_020_115	WEST EMPORIA - WILLIAMS BROTHERS PIPELINE COMPANY JUNCTION 115KV	80	0.4172	105.3575	JEFFERY ENERGY CENTER 230/26.0KV TRANSFORMER CKT 1
13G	08ALL	0	TO->FROM	G13_020_115	WEST EMPORIA - WILLIAMS BROTHERS PIPELINE COMPANY JUNCTION 115KV	80	0.37144	105.235	EMPORIA ENERGY CENTER - LANG 345KV CKT 1
13G	08ALL	0	TO->FROM	G13_020_115	WEST EMPORIA - WILLIAMS BROTHERS PIPELINE COMPANY JUNCTION 115KV	80	0.37144	105.235	LANG (LANG 1X) 345/115/14.4KV TRANSFORMER CKT 1
13G	08ALL	0	TO->FROM	G13_020_115	WEST EMPORIA - WILLIAMS BROTHERS PIPELINE COMPANY JUNCTION 115KV	80	0.4172	104.86	JEFFERY ENERGY CENTER 345/26.0KV TRANSFORMER CKT 1
13G	08ALL	0	TO->FROM	G13_020_115	WEST EMPORIA - WILLIAMS BROTHERS PIPELINE COMPANY JUNCTION 115KV	80	0.41571	104.1775	JEFFERY ENERGY CENTER - MORRIS COUNTY 345KV CKT 1
13G	08ALL	0	TO->FROM	G13_020_115	WEST EMPORIA - WILLIAMS BROTHERS PIPELINE COMPANY JUNCTION 115KV	80	0.4172	102.8825	JEFFERY ENERGY CENTER 345/26.0KV TRANSFORMER CKT 1
13G	08ALL	0	TO->FROM	G13_020_115	WEST EMPORIA - WILLIAMS BROTHERS PIPELINE COMPANY JUNCTION 115KV	80	0.4172	101.425	HILLSBORO - SPRING CREEK JUNCTION 115KV CKT 1
13G	08ALL	0	TO->FROM	G13_020_115	WEST EMPORIA - WILLIAMS BROTHERS PIPELINE COMPANY JUNCTION 115KV	80	0.4172	101.3925	LAWRENCE ENERGY CENTER UNIT 5 - LAWRENCE HILL 230KV CKT 1
13G	08ALL	0	TO->FROM	G13_020_115	WEST EMPORIA - WILLIAMS BROTHERS PIPELINE COMPANY JUNCTION 115KV	80	0.4172	101.3925	LAWRENCE ENERGY CENTER UNIT 5 230/24.0KV TRANSFORMER CKT 1
13G	08ALL	0	TO->FROM	G13_020_115	WEST EMPORIA - WILLIAMS BROTHERS PIPELINE COMPANY JUNCTION 115KV	80	0.4172	101.17	IATAN 345/25.0KV TRANSFORMER CKT 1
13G	08ALL	0	TO->FROM	G13_020_115	WEST EMPORIA - WILLIAMS BROTHERS PIPELINE COMPANY JUNCTION 115KV	80	0.41716	101.165	LACYGNE - STILWELL 345KV CKT 1
13G	08ALL	0	TO->FROM	G13_020_115	WEST EMPORIA - WILLIAMS BROTHERS PIPELINE COMPANY JUNCTION 115KV	80	0.41413	101.1575	EMPORIA ENERGY CENTER - WICHITA 345KV CKT 1
13G	08ALL	0	TO->FROM	G13_020_115	WEST EMPORIA - WILLIAMS BROTHERS PIPELINE COMPANY JUNCTION 115KV	80	0.41696	100.49	LACYGNE - WEST GARDNER 345KV CKT 1

SEASON	GROUP	SCENARIO	DIRECTION	SOURCE	MONITORED ELEMENT	RATE (MVA)	TDF	CONTINGENCY	
								LOADING %	CONTINGENCY
13G	08G13_020	0	FROM->TO	G13_020_345	WICHITA (WICHT11X) 345/138/13.8KV TRANSFORMER CKT 1	431.6	0.04838	104.6747	WICHITA (WICHT12X) 345/138/13.8KV TRANSFORMER CKT 1
13G	8	0	FROM->TO	G13_020_345	WICHITA (WICHT11X) 345/138/13.8KV TRANSFORMER CKT 1	431.6	0.04838	104.2263	WICHITA (WICHT12X) 345/138/13.8KV TRANSFORMER CKT 1
13G	08G13_020	0	FROM->TO	G13_020_345	WICHITA (WICHT11X) 345/138/13.8KV TRANSFORMER CKT 1	435.6	0.04838	103.5528	WICHITA (WICHT12X) 345/138/13.8KV TRANSFORMER CKT 1
13G	08ALL	0	FROM->TO	G13_020_345	WICHITA (WICHT11X) 345/138/13.8KV TRANSFORMER CKT 1	432.3	0.04837	103.5101	WICHITA (WICHT12X) 345/138/13.8KV TRANSFORMER CKT 1
13G	8	0	FROM->TO	G13_020_345	WICHITA (WICHT11X) 345/138/13.8KV TRANSFORMER CKT 1	435.6	0.04838	103.1085	WICHITA (WICHT12X) 345/138/13.8KV TRANSFORMER CKT 1
13G	08ALL	0	FROM->TO	G13_020_345	WICHITA (WICHT11X) 345/138/13.8KV TRANSFORMER CKT 1	436	0.04837	102.4711	WICHITA (WICHT12X) 345/138/13.8KV TRANSFORMER CKT 1
13G	08G13_020	0	FROM->TO	G13_020_345	WICHITA (WICHT12X) 345/138/13.8KV TRANSFORMER CKT 1	428.5	0.05145	112.063	WICHITA (WICHT11X) 345/138/13.8KV TRANSFORMER CKT 1
13G	8	0	FROM->TO	G13_020_345	WICHITA (WICHT12X) 345/138/13.8KV TRANSFORMER CKT 1	428.5	0.05145	111.5827	WICHITA (WICHT11X) 345/138/13.8KV TRANSFORMER CKT 1
13G	08ALL	0	FROM->TO	G13_020_345	WICHITA (WICHT12X) 345/138/13.8KV TRANSFORMER CKT 1	429.4	0.05144	110.7797	WICHITA (WICHT11X) 345/138/13.8KV TRANSFORMER CKT 1
13G	08G13_020	0	FROM->TO	G13_020_345	WICHITA (WICHT12X) 345/138/13.8KV TRANSFORMER CKT 1	434	0.05145	110.5046	WICHITA (WICHT11X) 345/138/13.8KV TRANSFORMER CKT 1
13G	8	0	FROM->TO	G13_020_345	WICHITA (WICHT12X) 345/138/13.8KV TRANSFORMER CKT 1	434	0.05145	110.0304	WICHITA (WICHT11X) 345/138/13.8KV TRANSFORMER CKT 1
13G	08ALL	0	FROM->TO	G13_020_345	WICHITA (WICHT12X) 345/138/13.8KV TRANSFORMER CKT 1	434.5	0.05144	109.3413	WICHITA (WICHT11X) 345/138/13.8KV TRANSFORMER CKT 1