

Impact Study of Limited Operation for Generator Interconnection

GEN-2011-054

April 2013
Generation Interconnection



Executive Summary

<OMITTED TEXT> (Customer; GEN-2011-054) has requested a Limited Operation System Impact Study under the Southwest Power Pool Open Access Transmission Tariff (OATT) for 299 MW of wind generation to be interconnected into the Transmission System of Oklahoma Gas & Electric (OKGE) in Canadian County, Oklahoma. GEN-2011-054, under GIA Section 5.9, has requested this Limited Operation Interconnection Study (LOIS) to determine the impacts of interconnecting to the transmission system before all required Network Upgrades identified in the DISIS-2011-002 (or most recent iteration) Impact Study can be placed into service.

The Customer has requested a restudy of the LOIS that was previously performed and posted to SPP OASIS on May 8, 2012. That study can be found at the following web address: http://sppoasis.spp.org/documents/swpp/transmission/studies/files/2011_Generation_Studies/GEN-2011-054_LOIS_05-08-2012_final.pdf. The Customer has requested a restudy of this LOIS to confirm that adequate interconnection service remains after the withdrawals and Commercial Operation commencement of certain higher queued projects.

This LOIS addresses the effects of interconnecting the plant to the rest of the transmission system for the system topology and conditions as expected in January 2014. GEN-2011-054 is requesting the interconnection of one hundred thirty (130) Siemens SWT 2.3 MW wind turbine generators and associated facilities into the Cimarron 345kV substation. For the typical LOIS, both a power flow and transient stability analysis are conducted. The LOIS assumes that only the higher queued projects listed within Table 1 of this study might go into service before the completion of all Network Upgrades identified within Table 2 of this report. If additional generation projects, listed within Table 3, with queue priority equal to or higher than the study project request rights to go into commercial operation before all Network Upgrades identified within Table 2 of this report are completed, this LOIS may need to be restudied to ensure that interconnection service remains for the GEN-2011-054 request.

Power flow analysis from this LOIS has determined that the GEN-2011-054 request can interconnect 299 MW of generation as an Energy Resource prior to the completion of the required Network Upgrades, listed within Table 2 of this report. Should any other projects, other than those listed within Table 1 of this report, come into service an additional study may be required to determine if any limited operation service is available. It should be noted that although this LOIS analyzed many of the most probable contingencies, it is not an all-inclusive list that can account for every operational situation. Additionally, the generator may not be able to inject any power onto the Transmission System due to constraints that fall below the threshold of mitigation for a Generator Interconnection request. Because of this, it is likely that the Customer may be required to reduce their generation output to 0 MW under certain system conditions to allow system operators to maintain the reliability of the transmission network.

Transient stability analysis for this LOIS has determined that the transmission system will remain stable for the one hundred ten (110) selected faults for the limited operation interconnection of GEN-2011-054 and will meet Low Voltage Ride Through (LVRT) requirements of FERC Order #661A.

Nothing in this study should be construed as a guarantee of transmission service. If the customer wishes to sell power from the facility, a separate request for transmission service must be requested on Southwest Power Pool's OASIS by the Customer.

Table of Contents

Executive Summary	i
Table of Contents	iii
Purpose	1
Facilities	5
Generating Facility	5
Interconnection Facilities	5
Base Case Network Upgrades	5
Power Flow Analysis	7
Model Preparation	7
Study Methodology and Criteria	7
Results	7
Limited Operation and System Reliability	8
Stability Analysis	10
Model Preparation	10
Disturbances.....	10
Results	13
FERC LVRT Compliance.....	16
Conclusion	17

Purpose

<OMITTED TEXT> (Interconnection Customer) has requested a restudy of a Limited Operation System Impact Study (LOIS) under the Southwest Power Pool (SPP) Open Access Transmission Tariff (OATT) for an interconnection request into the Transmission System of Oklahoma Gas & Electric (OKGE).

The purpose of this study is to reevaluate the impacts of interconnecting GEN-2011-054 request of 299 MW comprised of One hundred thirty (130) Siemens SWT 2.3 MW wind turbine generators and associated facilities interconnecting into the Cimarron 345kV substation in Canadian County, Oklahoma. The Customer has requested this amount to be studied with Limited Operation Interconnection Service to commence on or around January of 2014.

The Customer has requested a restudy of the LOIS that was previously performed and posted to SPP OASIS on May 8, 2012. That study can be found at the following web address:http://sppoasis.spp.org/documents/swpp/transmission/studies/files/2011_Generation_Studies/GEN-2011-054_LOIS_05-08-2012_final.pdf. The Customer has requested a restudy of this LOIS to confirm that adequate interconnection service remains after the withdrawals and Commercial Operation commencement of certain higher queued projects.

Both power flow and transient stability analysis were conducted for this Limited Operation Interconnection Service. Limited Operation Studies are conducted under GIA Section 5.9.

The LOIS considers the Base Case as well as all Generating Facilities (and with respect to (b) below, any identified Network Upgrades associated with such higher queued interconnection) that, on the date the LOIS is commenced:

- a) are directly interconnected to the Transmission System;
- b) are interconnected to Affected Systems and may have an impact on the Interconnection Request;
- c) have a pending higher queued Interconnection Request to interconnect to the Transmission System listed in Table 1; or
- d) have no Queue Position but have executed an LGIA or requested that an unexecuted LGIA be filed with FERC.

Any changes to these assumptions, for example, one or more of the previously queued requests not included within this study execute an interconnection agreement and commencing commercial operation, may require a re-study of this LOIS at the expense of the Customer.

Nothing within this System Impact Study constitutes a request for transmission service or confers upon the Interconnection Customer any right to receive transmission service rights. Should the Customer require transmission service, those rights should be requested through SPP's Open Access Same-Time Information System (OASIS).

This LOIS study included prior queued generation interconnection requests. Those listed within Table 1 are the generation interconnection requests that are assumed to have rights to either full or partial interconnection service prior to the requested 1/2014 in-service of GEN-2011-054 for this LOIS. Also listed in Table 1 are both the amount of MWs of interconnection service expected at the effective time of this study and the total MWs requested of interconnection service, the fuel type, the point of interconnection (POI), and the current status of each particular prior queued request.

Table 1: Generation Requests Included within LOIS

Project	MW	Total MW	Fuel Source	POI	Status
GEN-2001-014	96	96	Wind	Ft. Supply 138kV	IA FULLY EXECUTED/COMMERCIAL OPERATION
GEN-2001-037	120	120	Wind	FPL Moreland Tap 138kV	IA FULLY EXECUTED/COMMERCIAL OPERATION
GEN-2005-008	120	120	Wind	Woodward 138kV	IA FULLY EXECUTED/COMMERCIAL OPERATION
GEN-2006-024S	18.9	18.9	Wind	Buffalo Bear Tap 69kV	IA FULLY EXECUTED/COMMERCIAL OPERATION
GEN-2006-046	130	130	Wind	Dewey 138kV	IA FULLY EXECUTED/COMMERCIAL OPERATION
GEN-2007-025	300	300	Wind	Viola 345kV	IA FULLY EXECUTED/COMMERCIAL OPERATION
GEN-2007-043	200	200	Wind	Minco 345kV	IA FULLY EXECUTED/COMMERCIAL OPERATION
GEN-2007-050	170	170	Wind	Woodward EHV 138kV	IA FULLY EXECUTED/COMMERCIAL OPERATION
GEN-2008-003	101	101	Wind	Woodward EHV 138kV	IA FULLY EXECUTED/COMMERCIAL OPERATION
GEN-2008-013	300	300	Wind	Hunter 345kV	IA FULLY EXECUTED/COMMERCIAL OPERATION
GEN-2008-023	150	150	Wind	Hobart Junction 138kV	IA FULLY EXECUTED/COMMERCIAL OPERATION
GEN-2008-044	197.8	197.8	Wind	Tatonga 345kV	IA FULLY EXECUTED/COMMERCIAL OPERATION
GEN-2010-011	29.7	29.7	Wind	Tatonga 345kV	IA FULLY EXECUTED/COMMERCIAL OPERATION
GEN-2010-040	298.2	298.2	Wind	Cimarron 345kV	IA FULLY EXECUTED/ON SCHEDULE
GEN-2011-007	250	250	Wind	Tap Cimarron - Woodring (Matthewson) 345kV	IA FULLY EXECUTED/ON SCHEDULE
GEN-2011-010	100.8	100.8	Wind	Minco 345kV	IA FULLY EXECUTED/COMMERCIAL OPERATION

This LOIS was required because the Customer is requesting interconnection prior to the completion of all of their required upgrades listed within the latest iteration of their Definitive Interconnection System Impact Study (DISIS-2011-002). Table 2 below lists the required upgrade projects for which this request has cost responsibility. GEN-2011-054 was included within the DISIS-2011-002 that was posted January 31, 2012. The cluster has been restudied a number of times since the original posting. These reports can be located here at the following GI Study URL:

http://spooasis.spp.org/documents/swpp/transmission/GenStudies.cfm?YearType=2011_Impact_Studies.

Table 2: Upgrade Projects not included but Required for Full Interconnection Service

Upgrade Project	Type	Description	Status
Border – Woodward 345kV	Most recent iteration of DISIS 2011-002. Previous Network Upgrade not responsibility of Customer but required to support full interconnection.	Build Priority Project	Current Estimated In-Service date of 6/30/2014
Border – TUCO 345kV	Most recent iteration of DISIS 2011-002. Previous Network Upgrade not responsibility of Customer but required to support full interconnection.	Build Priority Project	Current Estimated In-Service date of 6/30/2014
Spearville – Clark – Thistle 345kV Dbl CKT	Most recent iteration of DISIS 2011-002. Previous Network Upgrade not responsibility of Customer but required to support full interconnection.	Build Priority Project	Current Estimated In-Service date of 12/31/2014
Thistle – Woodward 345kV CKT 1	Most recent iteration of DISIS 2011-002. Previous Network Upgrade not responsibility of Customer but required to support full interconnection.	Build Priority Project	Current Estimated In-Service date of 12/31/2014
TUCO 345/230kV Autotransformer CKT 2	Most recent iteration of DISIS 2011-002. Previous Network Upgrade not responsibility of Customer but required to support full interconnection.	Build Balanced Portfolio Project	Current Estimated In-Service date of 5/19/2014
Woodward 345/138kV Autotransformer CKT 2	Most recent iteration of DISIS 2011-002. Previous Network Upgrade not responsibility of Customer but required to support full interconnection.	Build Balanced Portfolio Project	Current Estimated In-Service date of 5/19/2014

Any changes to these assumptions, for example, one or more of the previously queued requests not included within this study execute an interconnection agreement and commencing commercial operation, may require a re-study of this LOIS at the expense of the Customer. The higher or equally queued projects that were not included in this study are listed in Table 3. While this list is not all inclusive it is a list of the most probable and affecting prior queued requests that were not included within this LOIS, either because no request for an LOIS has been made or the request is on suspension, etc.

Table 3: Higher or Equally Queued GI Requests not included within LOIS

Project	Remainder MW	Total MW	Fuel	POI	Status
GEN-2007-021	201	201	Wind	Tatonga 345kV	IA FULLY EXECUTED/ON SCHEDULE
GEN-2007-044	300	300	Wind	Tatonga 345kV	IA FULLY EXECUTED/ON SCHEDULE
GEN-2007-062	765	765	Wind	Woodward EHV 345kV	IA FULLY EXECUTED/ON SCHEDULE
GEN-2008-019	300	300	Wind	Tatonga 345kV	IA FULLY EXECUTED/ON SCHEDULE
GEN-2008-029	250.5	250.5	Wind	Woodward EHV 138kV	IA FULLY EXECUTED/ON SCHEDULE
GEN-2008-046	200	200	Wind	Sunnyside 345kV	IA FULLY EXECUTED/ON SUSPENSION
GEN-2008-071	76.8	76.8	Wind	Newkirk 138kV	IA FULLY EXECUTED/ON SUSPENSION
GEN-2009-016	100.8	100.8	Wind	Falcon Road 138kV	IA FULLY EXECUTED/ON SUSPENSION
GEN2011-019	299	299	Wind	Woodward 345kV	IA PENDING
GEN-2011-020	299	299	Wind	Woodward 345kV	IA PENDING
GEN-2011-024	299	299	Wind	Tatonga 345kV	IA PENDING

Nothing in this System Impact Study constitutes a request for transmission service or grants the Interconnection Customer any rights to transmission service.

Facilities

Generating Facility

GEN-2011-054 Interconnection Customer’s request to interconnect a total of 299 MW is comprised of one hundred thirty (130) Siemens SWT 2.3 MW wind turbine generators and associated interconnection facilities.

Interconnection Facilities

The POI for GEN-2011-054 Interconnection Customer is at the Cimarron 345kV substation in Canadian County, Oklahoma. Figure 1 depicts the one-line diagram of the local transmission system including the POI as well as the power flow model representing the request.

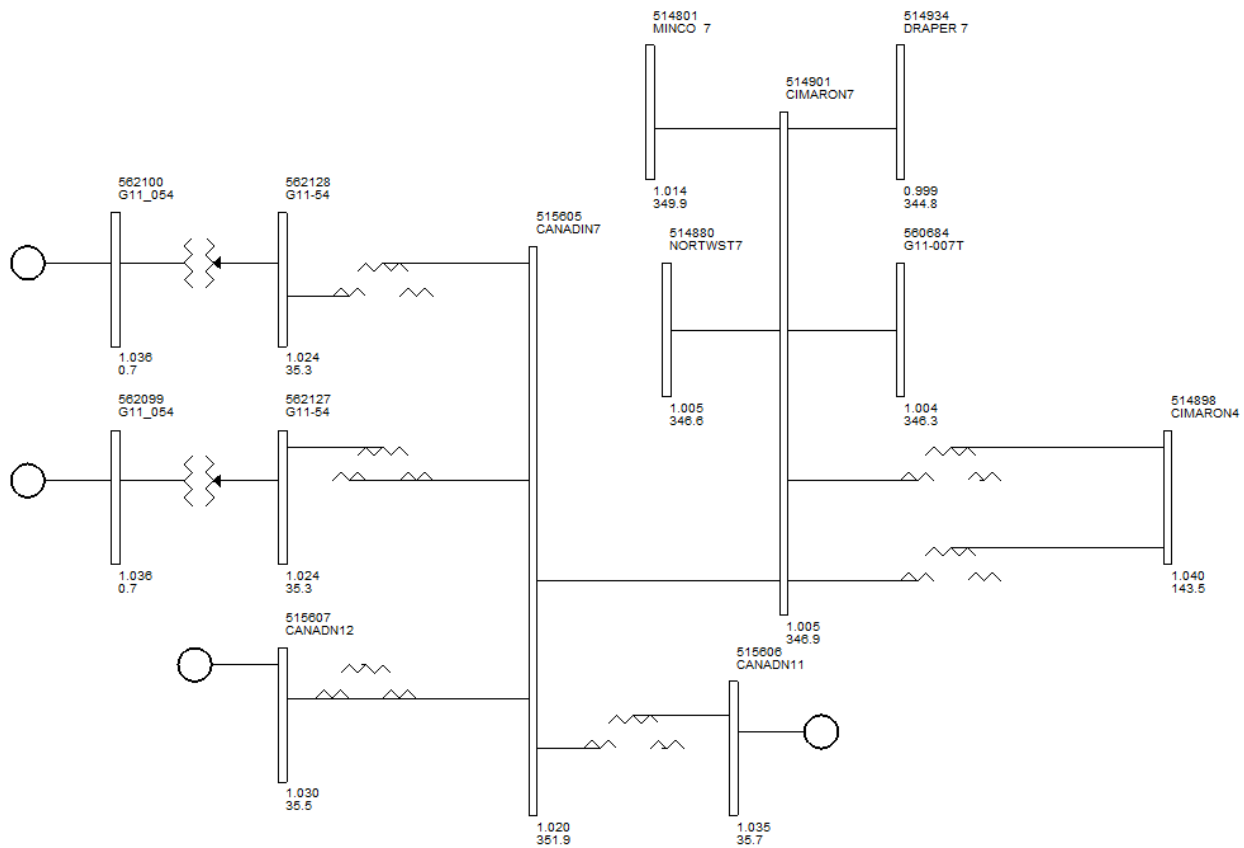

Figure 1: Proposed POI Configuration and Request Power Flow Model

Base Case Network Upgrades

The Network Upgrades included within the cases used for this LOIS study are those facilities that are a part of the SPP Transmission Expansion Plan or the Balanced Portfolio projects that have in-service dates prior to the GEN-2011-054 LOIS requested in-service date of January 2014. These

facilities have an approved Notice to Construct (NTC), or are in construction stages and expected to be in-service at the effective time of this study. No other upgrades were included for this LOIS. If for some reason, construction on these projects is delayed or discontinued, a restudy may be needed to determine the interconnection service availability of the Customer.

Power Flow Analysis

Power flow analysis is used to determine if the transmission system can accommodate the injection from the request without violating thermal or voltage transmission planning criteria.

Model Preparation

Power flow analysis was performed using modified versions of the 2012 series of transmission service request study models including the 2014 (spring, summer, and winter) seasonal models. To incorporate the Interconnection Customer's request, a re-dispatch of existing generation within SPP was performed with respect to the amount of the Customer's injection and the interconnecting Balancing Authority. This method allows the request to be studied as an Energy Resource (ERIS) Interconnection Request. For this LOIS, only the previous queued requests listed in Table 1 were assumed to be in-service.

Study Methodology and Criteria

The ACCC function of PSS/E is used to simulate contingencies, including single and multiple facility (i.e. breaker-to-breaker, etc.) outages, within all of the control areas of SPP and other control areas external to SPP and the resulting data analyzed. This satisfies the "more probable" contingency testing criteria mandated by NERC and the SPP criteria.

The contingency set includes all SPP control area branches and ties 69kV and above, first tier Non-SPP control area branches and ties 115 kV and above, any defined contingencies for these control areas, and generation unit outages for the SPP control areas with SPP reserve share program redispatch.

The monitor elements include all SPP control area branches, ties, and buses 69 kV and above, and all first tier Non-SPP control area branches and ties 69 kV and above. NERC Power Transfer Distribution Flowgates for SPP and first tier Non-SPP control area are monitored. Additional NERC Flowgates are monitored in second tier or greater Non-SPP control areas. Voltage monitoring was performed for SPP control area buses 69 kV and above.

Results

The LOIS ACCC analysis indicates that the Customer can interconnect generation into the OKGE transmission system as requested before all required upgrades listed within the DISIS-2011-002 study can be placed into service. Should any other GI projects, other than those listed within Table 1 of this report, come into service an additional study may be required to determine if any limited operation service is available.

ACCC results for the LOIS can be found in Tables 4, 5 and Appendix A below. Generator Interconnection Energy Resource analysis doesn't mitigate for those issues in which the affecting GI request has less than a 20% OTDF, Table 5 and Appendix A are provided for informational purposes only so that the Customer understands there may be operational conditions when they may be required to reduce their output to maintain system reliability.

Limited Operation and System Reliability

In no way does this study guarantee limited operation for all periods of time. It should be noted that although this LOIS analyzed many of the most probable contingencies, it is not an all-inclusive list and cannot account for every operational situation. Because of this, it is likely that the Customer may be required to reduce their generation output to 0 MW under certain system conditions to allow system operators to maintain the reliability of the transmission network.

Table 4: Interconnection Constraints for Mitigation of GEN-2011-054 LOIS @ 299MW

Season	Dispatch Group	Flow	Monitored Element	RATEA (MVA)	RATEB (MVA)	TDF	TC% LOADING	Max MW Available	Contingency
All	01G11_054		None					299	
All	1		None					299	

Table 5: Additional Constraints of GEN-2011-054 LOIS @ 299MW Not for Mitigation

Season	Dispatch Group	Flow	Monitored Element	RATEA (MVA)	RATEB (MVA)	TDF	TC% LOADING	ATC Available	Contingency
Spring	01G11_054		None						
Spring	1		None						

Stability Analysis

Transient stability analysis is used to determine if the transmission system can maintain angular stability and ensure bus voltages stay within planning criteria bandwidth during and after a disturbance while considering the addition of a generator interconnection request.

Model Preparation

Transient stability analysis was performed using modified versions of the 2012 series of Model Development Working Group (MDWG) dynamic study models including the 2014 summer and 2013 winter peak dynamic cases. The cases were adapted to resemble the power flow study cases with regards to prior queued generation requests and topology. Finally the prior queued and study generation was dispatched into the SPP footprint. Initial simulations are then carried out for a no-disturbance run of twenty (20) seconds to verify the numerical stability of the model.

Disturbances

The one hundred ten (110) contingencies were identified for the Limited Operation scenario for use in this study. These faults are listed within Table 6. These contingencies included three-phase faults and single-phase line faults at locations defined by SPP. Single-phase line faults were simulated by applying fault impedance to the positive sequence network at the fault location to represent the effect of the negative and zero sequence networks on the positive sequence network. The fault impedance was computed to give a positive sequence voltage at the specified fault location of approximately 60% of pre-fault voltage. This method is in agreement with SPP current practice.

With exception to transformers, the typical sequence of events for a three-phase and single-phase fault is as follows:

1. apply fault at particular location
2. continue fault for five (5) cycles, clear the fault by tripping the faulted facility
3. after an additional twenty (20) cycles, re-close the previous facility back into the fault
4. continue fault for five (5) additional cycles
5. trip the faulted facility and remove the fault

Transformer faults are typically only performed for three-phase faults, unless otherwise noted. Additionally the sequence of events for a transformer is to 1) apply a three-phase fault for five (5) cycles and 2) clear the fault by tripping the affected transformer facility. Unless otherwise noted there will be no re-closing into a transformer fault.

Table 6: Contingencies Evaluated for Limited Operation

Contingency Number and Name		Description
1	FLT_01_CIMARON7_MINCO7_345kV_3PH	3-Phase fault on the Cimaron –Minco 345kV line near the Cimarron 345kV bus.
2	FLT_02_CIMARON7_MINCO7_345kV_1PH	Single-phase fault similar to previous fault.
3	FLT_03_MINCO7_GRACMNT7_345kV_3PH	3-Phase fault on the Minco –Gracemont 345kV line near the Minco 345kV bus.
4	FLT_04_MINCO7_GRACMNT7_345kV_1PH	Single-phase fault similar to previous fault.
5	FLT_05_GRACMNT7_LES7_345kV_3PH	3-Phase fault on the Gracemont –Lawton Eastside 345kV line near the Gracemont 345kV bus.
6	FLT_06_GRACMNT7_LES7_345kV_1PH	Single-phase fault similar to previous fault.
7	FLT_07_GRACMNT7_GRACMNT4_345_138kV_3PH	3-Phase fault on the Gracemont 345kV/138kV transformer near the Gracemont 345kV bus.
8	FLT_08_GRACMNT7_GRACMNT4_345_138kV_1PH	Single-phase fault similar to previous fault.
9	FLT_09_LES7_OKU7_345kV_3PH	3-Phase fault on the Lawton Eastside-Oklaunion 345kV line near the Lawton Eastside 345kV bus.
10	FLT_10_LES7_OKU7_345kV_1PH	Single-phase fault similar to previous fault.
11	FLT_11_LES7_SUNNYS7_345kV_3PH	3-Phase fault on the Lawton Eastside –Sunnyside 345kV line near the Lawton Eastside 115kV bus.
12	FLT_12_LES7_SUNNYS7_345kV_1PH	Single-phase fault similar to previous fault.
13	FLT_13_LES7_LES4_345_138kV_3PH	3-Phase fault on the Lawton Eastside 345kV/138kV circuit #1 transformer near the Lawton Eastside 345kV bus.
14	FLT_14_LES7_LES4_345_138kV_1PH	Single-phase fault similar to previous fault.
15	FLT_15_LES7_LES4_345_138kV_3PH	3-Phase fault on the Lawton Eastside 345kV/138kV circuit #2 transformer near the Lawton Eastside 345kV bus.
16	FLT_16_LES7_LES4_345_138kV_1PH	Single-phase fault similar to previous fault.
17	FLT_17_CIMARON7_NORTWST7_345kV_3PH	3-Phase fault on the Cimaron –Northwest 345kV line near the Cimaron 345kV bus.
18	FLT_18_CIMARON7_NORTWST7_345kV_1PH	Single-phase fault similar to previous fault.
19	FLT_19_NORTWST7_SPRNGCK7_345kV_3PH	3-Phase fault on the Northwest – Spring Creek345kV line near the Northwest 345kV bus.
20	FLT_20_NORTWST7_SPRNGCK7_345kV_1PH	Single-phase fault similar to previous fault.
21	FLT_21_NORTWST7_ARCADIA7_345kV_3PH	3-Phase fault on the Northwest – Arcadia 345kV line near the Northwest 345kV bus.
22	FLT_22_NORTWST7_ARCADIA7_345kV_1PH	Single-phase fault similar to previous fault.
23	FLT_23_NORTWST7_MATTHEWSON_345kV_3PH	3-Phase fault on the Northwest– Matthewson 2 345kV line near the Northwest 345kV bus.
24	FLT_24_NORTWST7_MATTHEWSON_345kV_1PH	Single-phase fault similar to previous fault.
25	FLT_25_NORTWST7_NORTWST4_345_138kV_3PH	3-Phase fault on the Northwest 345kV/138kV circuit 1 transformer near the Northwest 345kV bus.
26	FLT_26_NORTWST7_NORTWST4_345_138kV_1PH	Single-phase fault similar to previous fault.
27	FLT_27_NORTWST7_NORTWST4_345_138kV_3PH	3-Phase fault on the Northwest 345kV/138kV circuit 2 transformer near the Northwest 345kV bus.
28	FLT_28_NORTWST7_NORTWST4_345_138kV_1PH	Single-phase fault similar to previous fault.
29	FLT_29_SPRNGCK7_SOONER7_345kV_3PH	3-Phase fault on the Springcreek – Sooner 345kV line near the Springcreek 345kV bus.
30	FLT_30_SPRNGCK7_SOONER7_345kV_1PH	Single-phase fault similar to previous fault.
31	FLT_31_SOONER7_CLEVLND7_345kV_3PH	3-Phase fault on the Sooner – Cleaveland1 345kV line near the Sooner 345kV bus.
32	FLT_32_SOONER7_CLEVLND7_345kV_1PH	Single-phase fault similar to previous fault.
33	FLT_33_SOONER7_WOODRNG7_345kV_3PH	3-Phase fault on the Sooner – Woodring 345kV line near the Sooner 345kV bus.
34	FLT_34_SOONER7_WOODRNG7_345kV_1PH	Single-phase fault similar to previous fault.
35	FLT_35_SOONER7_ROSEHIL7_345kV_3PH	3-Phase fault on the Sooner – Rose Hill 345kV line near the Sooner 345kV bus.
36	FLT_36_SOONER7_ROSEHIL7_345kV_1PH	Single-phase fault similar to previous fault.
37	FLT_37_SOONER7_SOONER4_345_138kV_3PH	3-Phase fault on the Sooner 345kV/138kV transformer near the Sooner 345kV bus.

Contingency Number and Name		Description
38	FLT_38_SOONER7_SOONER4_345_138kV_1PH	Single-phase fault similar to previous fault.
39	FLT_39_ARCADIA7_REDBUD7_345kV_3PH	3-Phase fault on the Arcadia – RedBud circuit #1 345kV line near the Arcadia 345kV bus.
40	FLT_40_ARCADIA7_REDBUD7_345kV_1PH	Single-phase fault similar to previous fault.
41	FLT_41_ARCADIA7_REDBUD7_345kV_3PH	3-Phase fault on the Arcadia – RedBud circuit #2 345kV line near the Arcadia 345kV bus.
42	FLT_42_ARCADIA7_REDBUD7_345kV_1PH	Single-phase fault similar to previous fault.
43	FLT_43_ARCADIA7_SEMINOL7_345kV_3PH	3-Phase fault on the Arcadia – Seminole 345kV line near the Arcadia 345kV bus.
44	FLT_44_ARCADIA7_SEMINOL7_345kV_1PH	Single-phase fault similar to previous fault.
45	FLT_45_ARCADIA7_ARCADIA4_345_138kV_3PH	3-Phase fault on the Arcadia 345kV/138kV circuit 1 transformer near the Arcadia 345kV bus.
46	FLT_46_ARCADIA7_ARCADIA4_345_138kV_1PH	Single-phase fault similar to previous fault.
47	FLT_47_ARCADIA7_ARCADIA4_345_138kV_3PH	3-Phase fault on the Arcadia 345kV/138kV circuit 2 transformer near the Arcadia 345kV bus.
48	FLT_48_ARCADIA7_ARCADIA4_345_138kV_1PH	Single-phase fault similar to previous fault.
49	FLT_49_ARCADIA7_ARCADIA4_345_138kV_3PH	3-Phase fault on the Arcadia 345kV/138kV circuit 3 transformer near the Arcadia 345kV bus.
50	FLT_50_ARCADIA7_ARCADIA4_345_138kV_1PH	Single-phase fault similar to previous fault.
51	FLT_51_REDBUD7_RSS7_345kV_3PH	3-Phase fault on the RedBud – R.S.S. 345kV line near the RedBud 345kV bus.
52	FLT_52_REDBUD7_RSS7_345kV_1PH	Single-phase fault similar to previous fault.
53	FLT_53_SEMINOL7_PITTSB7_345kV_3PH	3-Phase fault on the Seminole – Pittsburgh 345kV line near the Seminole 345kV bus.
54	FLT_54_SEMINOL7_PITTSB7_345kV_1PH	Single-phase fault similar to previous fault.
55	FLT_55_SEMINOL7_DRAPER7_345kV_3PH	3-Phase fault on the Seminole – Draper 345kV circuit 1 line near the Seminole 345kV bus.
56	FLT_56_SEMINOL7_DRAPER7_345kV_1PH	Single-phase fault similar to previous fault.
57	FLT_57_SEMINOL7_DRAPER7_345kV_3PH	3-Phase fault on the Seminole – Draper 345kV circuit 2 line near the Seminole 345kV bus.
58	FLT_58_SEMINOL7_DRAPER7_345kV_1PH	Single-phase fault similar to previous fault.
59	FLT_59_SEMINOL7_DRAPER7_345kV_3PH	3-Phase fault on the Seminole – Draper 345kV circuit 2 line near the Seminole 345kV bus.
60	FLT_60_SEMINOL7_DRAPER7_345kV_1PH	Single-phase fault similar to previous fault.
61	FLT_61_SEMINOL7_MUSKOGEE7_345kV_3PH	3-Phase fault on the Seminole – Muskogee 345kV line near the Seminole 345kV bus.
62	FLT_62_SEMINOL7_MUSKOGEE7_345kV_1PH	Single-phase fault similar to previous fault.
63	FLT_63_SEMINOL7_SEMINOL4_345_138kV_3PH	3-Phase fault on the Seminole 345kV/138kV circuit 1 transformer near the Seminole 345kV bus.
64	FLT_64_SEMINOL7_SEMINOL4_345_138kV_1PH	Single-phase fault similar to previous fault.
65	FLT_65_SEMINOL7_SEMINOL4_345_138kV_3PH	3-Phase fault on the Seminole 345kV/138kV circuit 2 transformer near the Seminole 345kV bus.
66	FLT_66_SEMINOL7_SEMINOL4_345_138kV_1PH	Single-phase fault similar to previous fault.
67	FLT_67_MATTHEWSON_TATONGA7_345kV_3PH	3-Phase fault on the Matthewson 2 – Tatonga 345kV line near the Matthewson 2 345kV bus.
68	FLT_68_MATTHEWSON_TATONGA7_345kV_1PH	Single-phase fault similar to previous fault.
69	FLT_69_TATONGA7_WWRDEHV7_345kV_3PH	3-Phase fault on the Tatonga – Woodward 345kV line near the Matthewson 2 345kV bus.
70	FLT_70_TATONGA7_WWRDEHV7_345kV_1PH	Single-phase fault similar to previous fault.
71	FLT_71_WWRDEHV7_WWDREHV4_345_138kV_3PH	3-Phase fault on the Woodward 345kV/138kV circuit 1 transformer near the Woodward 345kV bus.
72	FLT_72_WWRDEHV7_WWDREHV4_345_138kV_1PH	Single-phase fault similar to previous fault.
73	FLT_73_WWRDEHV7_WWDREHV4_345_138kV_3PH	3-Phase fault on the Woodward 345kV/138kV circuit 2 transformer near the Woodward 345kV bus.
74	FLT_74_WWRDEHV7_WWDREHV4_345_138kV_1PH	Single-phase fault similar to previous fault.
75	FLT_75_CIMARON7_DRAPER7_345kV_3PH	3-Phase fault on the Cimaron – Draper 345kV line near the Cimarron 345kV bus.
76	FLT_76_CIMARON7_DRAPER7_345kV_1PH	Single-phase fault similar to previous fault.

Contingency Number and Name		Description
77	FLT_77_DRAPER7_DRAPER4_345_138kV_3PH	3-Phase fault on the Draper 345kV/138kV circuit 1 transformer near the Draper 345kV bus.
78	FLT_78_DRAPER7_DRAPER4_345_138kV_1PH	Single-phase fault similar to previous fault.
79	FLT_79_DRAPER7_DRAPER4_345_138kV_3PH	3-Phase fault on the Draper 345kV/138kV circuit 2 transformer near the Draper 345kV bus.
80	FLT_80_DRAPER7_DRAPER4_345_138kV_1PH	Single-phase fault similar to previous fault.
81	FLT_81_DRAPER7_DRAPER4_345_138kV_3PH	3-Phase fault on the Draper 345kV/138kV circuit 3 transformer near the Draper 345kV bus.
82	FLT_82_DRAPER7_DRAPER4_345_138kV_1PH	Single-phase fault similar to previous fault.
83	FLT_83_CIMARON7_GEN 11-07T_345kV_3PH	3-Phase fault on the Cimarron – GEN 11-07T 345kV line near the Cimarron 345kV bus.
84	FLT_84_CIMARON7_GEN 11-07T_345kV_1PH	Single-phase fault similar to previous fault.
85	FLT_85_GEN 11-07T_WOODRNG7_345kV_3PH	3-Phase fault on the GEN 11-07T – Woodring 345kV line near the GEN 11-07T 345kV bus.
86	FLT_86_GEN 11-07T_WOODRNG7_345kV_1PH	Single-phase fault similar to previous fault.
87	FLT_87_WOODRNG7_HUNTERS7_345kV_3PH	3-Phase fault on the Woodring – Hunters 345kV line near the Woodring 345kV bus.
88	FLT_88_WOODRNG7_HUNTERS7_345kV_1PH	Single-phase fault similar to previous fault.
89	FLT_89_WOODRNG7_WOODRNG4_345_138kV_3PH	3-Phase fault on the Woodring 345kV/138kV transformer near the Woodring 345kV bus.
90	FLT_90_WOODRNG7_WOODRNG4_345_138kV_1PH	Single-phase fault similar to previous fault.
91	FLT_91_HUNTERS7_VIOLA7_345kV_3PH	3-Phase fault on the Hunters – Viola 345kV line near the Hunters 345kV bus.
92	FLT_92_HUNTERS7_VIOLA7_345kV_1PH	Single-phase fault similar to previous fault.
93	FLT_93_VIOLA7_WICHITA7_345kV_3PH	3-Phase fault on the Viola – Wichita 345kV line near the Wichita 345kV bus.
94	FLT_94_VIOLA7_WICHITA7_345kV_1PH	Single-phase fault similar to previous fault.
95	FLT_95_CIMARON7_CIMARON4_345_138kV_3PH	3-Phase fault on the Cimarron 345kV/138kV circuit 1 transformer near the Cimarron 345kV bus.
96	FLT_96_CIMARON7_CIMARON4_345_138kV_1PH	Single-phase fault similar to previous fault.
97	FLT_97_CIMARON7_CIMARON4_345_138kV_3PH	3-Phase fault on the Cimarron 345kV/138kV circuit 2 transformer near the Cimarron 345kV bus.
98	FLT_98_CIMARON7_CIMARON4_345_138kV_1PH	Single-phase fault similar to previous fault.
99	FLT_99_CIMARON4_TUTCONT4_138kV_3PH	3-Phase fault on the Cimarron – Tuttle Conoco Tap 138kV line near the Cimarron 138kV bus.
100	FLT_100_CIMARON4_TUTCONT4_138kV_1PH	Single-phase fault similar to previous fault.
101	FLT_101_CIMARON4_ELRENO4_138kV_3PH	3-Phase fault on the Cimarron – El Reno 138kV line near the Cimarron 138kV bus.
102	FLT_102_CIMARON4_ELRENO4_138kV_1PH	Single-phase fault similar to previous fault.
103	FLT_103_CIMARON4_JENSENT4_138kV_3PH	3-Phase fault on the Cimarron – Jensen Tap 138kV line near the Cimarron 138kV bus.
104	FLT_104_CIMARON4_JENSENT4_138kV_1PH	Single-phase fault similar to previous fault.
105	FLT_105_CIMARON4_HAYMAKR4_138kV_3PH	3-Phase fault on the Cimarron – Haymaker 138kV line near the Cimarron 138kV bus.
106	FLT_106_CIMARON4_HAYMAKR4_138kV_1PH	Single-phase fault similar to previous fault.
107	FLT_107_CIMARON4_CZECHAL4_138kV_3PH	3-Phase fault on the Cimarron – Czech Hall 138kV line near the Cimarron 138kV bus.
108	FLT_108_CIMARON4_CZECHAL4_138kV_1PH	Single-phase fault similar to previous fault.
109	FLT_109_CIMARON4_SARA4_138kV_3PH	3-Phase fault on the Cimarron – Sara 138kV line near the Cimarron 138kV bus.
110	FLT_110_CIMARON4_SARA4_138kV_1PH	Single-phase fault similar to previous fault.

Results

Results of the stability analysis are summarized in Table 7. These results are valid for GEN-2011-054 interconnecting with a generation amount up to 299 MW

Table 7: Fault Analysis Results for Limited Operation

Contingency Number and Name		2014SP	2013WP
1	FLT_01_CIMARON7_MINCO7_345kV_3PH	Stable	Stable
2	FLT_02_CIMARON7_MINCO7_345kV_1PH	Stable	Stable
3	FLT_03_MINCO7_GRACMNT7_345kV_3PH	Stable	Stable
4	FLT_04_MINCO7_GRACMNT7_345kV_1PH	Stable	Stable
5	FLT_05_GRACMNT7_LES7_345kV_3PH	Stable	Stable
6	FLT_06_GRACMNT7_LES7_345kV_1PH	Stable	Stable
7	FLT_07_GRACMNT7_GRACMNT4_345_138kV_3PH	Stable	Stable
8	FLT_08_GRACMNT7_GRACMNT4_345_138kV_1PH	Stable	Stable
9	FLT_09_LES7_OKU7_345kV_3PH	Stable	Stable
10	FLT_10_LES7_OKU7_345kV_1PH	Stable	Stable
11	FLT_11_LES7_SUNNYS7_345kV_3PH	Stable	Stable
12	FLT_12_LES7_SUNNYS7_345kV_1PH	Stable	Stable
13	FLT_13_LES7_LES4_345_138kV_3PH	Stable	Stable
14	FLT_14_LES7_LES4_345_138kV_1PH	Stable	Stable
15	FLT_15_LES7_LES4_345_138kV_3PH	Stable	Stable
16	FLT_16_LES7_LES4_345_138kV_1PH	Stable	Stable
17	FLT_17_CIMARON7_NORTWST7_345kV_3PH	Stable	Stable
18	FLT_18_CIMARON7_NORTWST7_345kV_1PH	Stable	Stable
19	FLT_19_NORTWST7_SPRNGCK7_345kV_3PH	Stable	Stable
20	FLT_20_NORTWST7_SPRNGCK7_345kV_1PH	Stable	Stable
21	FLT_21_NORTWST7_ARCADIA7_345kV_3PH	Stable	Stable
22	FLT_22_NORTWST7_ARCADIA7_345kV_1PH	Stable	Stable
23	FLT_23_NORTWST7_MATTHEWSON_345kV_3PH	Stable	Stable
24	FLT_24_NORTWST7_MATTHEWSON_345kV_1PH	Stable	Stable
25	FLT_25_NORTWST7_NORTWST4_345_138kV_3PH	Stable	Stable
26	FLT_26_NORTWST7_NORTWST4_345_138kV_1PH	Stable	Stable
27	FLT_27_NORTWST7_NORTWST4_345_138kV_3PH	Stable	Stable
28	FLT_28_NORTWST7_NORTWST4_345_138kV_1PH	Stable	Stable
29	FLT_29_SPRNGCK7_SOONER7_345kV_3PH	Stable	Stable
30	FLT_30_SPRNGCK7_SOONER7_345kV_1PH	Stable	Stable
31	FLT_31_SOONER7_CLEVLND7_345kV_3PH	Stable	Stable
32	FLT_32_SOONER7_CLEVLND7_345kV_1PH	Stable	Stable
33	FLT_33_SOONER7_WOODRNG7_345kV_3PH	Stable	Stable
34	FLT_34_SOONER7_WOODRNG7_345kV_1PH	Stable	Stable
35	FLT_35_SOONER7_ROSEHIL7_345kV_3PH	Stable	Stable
36	FLT_36_SOONER7_ROSEHIL7_345kV_1PH	Stable	Stable
37	FLT_37_SOONER7_SOONER4_345_138kV_3PH	Stable	Stable
38	FLT_38_SOONER7_SOONER4_345_138kV_1PH	Stable	Stable
39	FLT_39_ARCADIA7_REDBUD7_345kV_3PH	Stable	Stable
40	FLT_40_ARCADIA7_REDBUD7_345kV_1PH	Stable	Stable
41	FLT_41_ARCADIA7_REDBUD7_345kV_3PH	Stable	Stable
42	FLT_42_ARCADIA7_REDBUD7_345kV_1PH	Stable	Stable
43	FLT_43_ARCADIA7_SEMINOL7_345kV_3PH	Stable	Stable
44	FLT_44_ARCADIA7_SEMINOL7_345kV_1PH	Stable	Stable
45	FLT_45_ARCADIA7_ARCADIA4_345_138kV_3PH	Stable	Stable
46	FLT_46_ARCADIA7_ARCADIA4_345_138kV_1PH	Stable	Stable
47	FLT_47_ARCADIA7_ARCADIA4_345_138kV_3PH	Stable	Stable
48	FLT_48_ARCADIA7_ARCADIA4_345_138kV_1PH	Stable	Stable
49	FLT_49_ARCADIA7_ARCADIA4_345_138kV_3PH	Stable	Stable
50	FLT_50_ARCADIA7_ARCADIA4_345_138kV_1PH	Stable	Stable
51	FLT_51_REDBUD7_RSS7_345kV_3PH	Stable	Stable
52	FLT_52_REDBUD7_RSS7_345kV_1PH	Stable	Stable
53	FLT_53_SEMINOL7_PITTSB7_345kV_3PH	Stable	Stable
54	FLT_54_SEMINOL7_PITTSB7_345kV_1PH	Stable	Stable

Contingency Number and Name		2014SP	2013WP
55	FLT_55_SEMINOL7_DRAPER7_345kv_3PH	Stable	Stable
56	FLT_56_SEMINOL7_DRAPER7_345kv_1PH	Stable	Stable
57	FLT_57_SEMINOL7_DRAPER7_345kv_3PH	Stable	Stable
58	FLT_58_SEMINOL7_DRAPER7_345kv_1PH	Stable	Stable
59	FLT_59_SEMINOL7_DRAPER7_345kv_3PH	Stable	Stable
60	FLT_60_SEMINOL7_DRAPER7_345kv_1PH	Stable	Stable
61	FLT_61_SEMINOL7_MUSKOG7_345kv_3PH	Stable	Stable
62	FLT_62_SEMINOL7_MUSKOG7_345kv_1PH	Stable	Stable
63	FLT_63_SEMINOL7_SEMINOL4_345_138kv_3PH	Stable	Stable
64	FLT_64_SEMINOL7_SEMINOL4_345_138kv_1PH	Stable	Stable
65	FLT_65_SEMINOL7_SEMINOL4_345_138kv_3PH	Stable	Stable
66	FLT_66_SEMINOL7_SEMINOL4_345_138kv_1PH	Stable	Stable
67	FLT_67_MATTHEWSON_TATONGA7_345kv_3PH	Stable	Stable
68	FLT_68_MATTHEWSON_TATONGA7_345kv_1PH	Stable	Stable
69	FLT_69_TATONGA7_WWRDEHV7_345kv_3PH	Stable	Stable
70	FLT_70_TATONGA7_WWRDEHV7_345kv_1PH	Stable	Stable
71	FLT_71_WWRDEHV7_WWDREHV4_345_138kv_3PH	Stable	Stable
72	FLT_72_WWRDEHV7_WWDREHV4_345_138kv_1PH	Stable	Stable
73	FLT_73_WWRDEHV7_WWDREHV4_345_138kv_3PH	Stable	Stable
74	FLT_74_WWRDEHV7_WWDREHV4_345_138kv_1PH	Stable	Stable
75	FLT_75_CIMARON7_DRAPER7_345kv_3PH	Stable	Stable
76	FLT_76_CIMARON7_DRAPER7_345kv_1PH	Stable	Stable
77	FLT_77_DRAPER7_DRAPER4_345_138kv_3PH	Stable	Stable
78	FLT_78_DRAPER7_DRAPER4_345_138kv_1PH	Stable	Stable
79	FLT_79_DRAPER7_DRAPER4_345_138kv_3PH	Stable	Stable
80	FLT_80_DRAPER7_DRAPER4_345_138kv_1PH	Stable	Stable
81	FLT_81_DRAPER7_DRAPER4_345_138kv_3PH	Stable	Stable
82	FLT_82_DRAPER7_DRAPER4_345_138kv_1PH	Stable	Stable
83	FLT_83_CIMARON7_GEN 11-07T_345kv_3PH	Stable	Stable
84	FLT_84_CIMARON7_GEN 11-07T_345kv_1PH	Stable	Stable
85	FLT_85_GEN 11-07T_WOODRNG7_345kv_3PH	Stable	Stable
86	FLT_86_GEN 11-07T_WOODRNG7_345kv_1PH	Stable	Stable
87	FLT_87_WOODRNG7_HUNTERS7_345kv_3PH	Stable	Stable
88	FLT_88_WOODRNG7_HUNTERS7_345kv_1PH	Stable	Stable
89	FLT_89_WOODRNG7_WOODRNG4_345_138kv_3PH	Stable	Stable
90	FLT_90_WOODRNG7_WOODRNG4_345_138kv_1PH	Stable	Stable
91	FLT_91_HUNTERS7_VIOLA7_345kv_3PH	Stable	Stable
92	FLT_92_HUNTERS7_VIOLA7_345kv_1PH	Stable	Stable
93	FLT_93_VIOLA7_WICHITA7_345kv_3PH	Stable	Stable
94	FLT_94_VIOLA7_WICHITA7_345kv_1PH	Stable	Stable
95	FLT_95_CIMARON7_CIMARON4_345_138kv_3PH	Stable	Stable
96	FLT_96_CIMARON7_CIMARON4_345_138kv_1PH	Stable	Stable
97	FLT_97_CIMARON7_CIMARON4_345_138kv_3PH	Stable	Stable
98	FLT_98_CIMARON7_CIMARON4_345_138kv_1PH	Stable	Stable
99	FLT_99_CIMARON4_TUTCONT4_138kv_3PH	Stable	Stable
100	FLT_100_CIMARON4_TUTCONT4_138kv_1PH	Stable	Stable
101	FLT_101_CIMARON4_ELRENO4_138kv_3PH	Stable	Stable
102	FLT_102_CIMARON4_ELRENO4_138kv_1PH	Stable	Stable
103	FLT_103_CIMARON4_JENSENT4_138kv_3PH	Stable	Stable
104	FLT_104_CIMARON4_JENSENT4_138kv_1PH	Stable	Stable
105	FLT_105_CIMARON4_HAYMAKR4_138kv_3PH	Stable	Stable
106	FLT_106_CIMARON4_HAYMAKR4_138kv_1PH	Stable	Stable
107	FLT_107_CIMARON4_CZECHAL4_138kv_3PH	Stable	Stable
108	FLT_108_CIMARON4_CZECHAL4_138kv_1PH	Stable	Stable
109	FLT_109_CIMARON4_SARA4_138kv_3PH	Stable	Stable
110	FLT_110_CIMARON4_SARA4_138kv_1PH	Stable	Stable

FERC LVRT Compliance

FERC Order #661A places specific requirements on wind farms through its Low Voltage Ride Through (LVRT) provisions. For Interconnection Agreements signed after December 31, 2006, wind farms shall stay on line for faults at the POI that draw the voltage down at the POI to 0.0 pu.

Fault contingencies were developed to verify that wind farms remain on line when the POI voltage is drawn down to 0.0 pu. These contingencies are shown in Table 8.

Table 8: LVRT Contingencies

Contingency Number and Name		Description
1	FLT_01_CIMARON7_MINCO7_345kV_3PH	3-Phase fault on the Cimaron –Minco 345kV line near the Cimarron 345kV bus.
2	FLT_17_CIMARON7_NORTWST7_345kV	3-Phase fault on the Cimaron –Northwest 345kV line near the Cimaron 345kV bus.
3	FLT_75_CIMARON7_DRAPER7_345kV_3PH	3-Phase fault on the Cimaron – Draper 345kV line near the Cimarron 345kV bus.
4	FLT_83_CIMARON7_GEN 11-07T_345kV_3PH	3-Phase fault on the Cimaron – GEN 11-07T 345kV line near the Cimarron 345kV bus.
5	FLT_95_CIMARON7_CIMARON4_345_138kV_3PH	3-Phase fault on the Cimarron 345kV/138kV circuit 1 transformer near the Cimarron 345kV bus.
6	FLT_97_CIMARON7_CIMARON4_345_138kV_3PH	3-Phase fault on the Cimarron 345kV/138kV circuit 2 transformer near the Cimarron 345kV bus.

The study and prior queued project wind farms remained online for the fault contingencies described in this section as well as the fault contingencies described in the Disturbances section of this report. GEN-2011-054 is found to be in compliance with FERC Order #661A.

Conclusion

<OMITTED TEXT> (Interconnection Customer, GEN-2011-054) has requested a Limited Operation System Impact Study under the Southwest Power Pool Open Access Transmission Tariff (OATT) for 299 MW of wind generation to be interconnected into a transmission facility of Oklahoma Gas & Electric (OKGE) in Canadian County, Oklahoma. The point of interconnection will be the Cimarron 345kV substation in Canadian County, Oklahoma. GEN-2011-054, under GIA Section 5.9, has requested this Limited Operation Interconnection Study (LOIS) to determine the impacts of interconnecting to the transmission system before all required Network Upgrades identified in the DISIS-2011-002 (or most recent iteration) Impact Study can be placed into service.

Power flow analysis from this LOIS has determined that the GEN-2011-054 request can interconnect prior to the completion of the required Network Upgrades, listed within Table 2 of this report.

Transient stability analysis indicates that with all with the power factor requirements stated in the DISIS-2011-002 study and with transmission topology as expected on January 1, 2014, the transmission system will remain stable for the contingencies listed within Table 6 with the addition of GEN-2011-054 generation. Additionally, GEN-2011-054 was found to be in compliance with FERC Order #661A when studied as listed within this report.

Any changes to these assumptions, for example, one or more of the previously queued requests not included within this study execute an interconnection agreement and commencing commercial operation, may require a re-study of this LOIS at the expense of the Customer.

Nothing in this System Impact Study constitutes a request for transmission service or confers upon the Interconnection Customer any right to receive transmission service.