



SPP

*Southwest
Power Pool*

***Facility Study
For
Generation Interconnection
Request
GEN-2010-045***

***SPP Generation
Interconnection***

(#GEN-2010-045)

July 2011

Summary

Sunflower Electric Power Corporation (SUNC) performed a detailed Facility Study at the request of Southwest Power Pool (SPP) for Generation Interconnection request GEN-2010-045. The request for interconnection was placed with SPP in accordance with SPP's Open Access Transmission Tariff, which covers new generation interconnections on SPP's transmission system.

Interconnection Customer Interconnection Facilities

The Interconnection Customer will be responsible for the 345 kV transmission line from its wind turbine Collector Substation to the Point of Interconnection (POI), the Gray County 345kV substation located in Gray County. In addition, the customer will be responsible for reactive power compensation equipment to maintain 95% lagging (providing vars) and 95% leading (absorbing vars) power factor at the point of interconnection.

Transmission Owner Interconnection Facilities and Non-Shared Network Upgrades

Per the following Facility Study, the Interconnection Customer is responsible for **\$5,000,000** of Transmission Owner Interconnection Facilities and non-shared network upgrades.

Shared Network Upgrades

The interconnection customer was studied within the DISIS-2010-002 Impact Study. At this time, the Interconnection Customer is allocated the following cost for shared network upgrades:

Upgrade Description	Allocated Cost	Total Cost
Beaver County – Gray County 345kV. Build 345kV transmission line between Beaver County and Kansas State Line. Includes substation work at Beaver County. (Construction by OG&E)	\$28,112,592	\$105,609,050
Beaver County – Gray County 345kV. Build 48 miles of 345kV transmission line between Gray County and Oklahoma State Line. Includes construction of additional 345kV line terminal with reactor at Gray County. (Construction by Sunflower)	\$17,196,191	\$64,600,000
St. John – St. John 115kV CKT 1. Rebuild 115kV tie between St. John – St. John transmission line. (Construction by MIDW)	\$84,588	\$500,000
Total	\$50,390,963	

If higher queued interconnection customers withdraw from the queue, suspend or terminate their GIA, restudies will have to be conducted to determine the Interconnection Customers' allocation of shared network upgrades. All studies have been conducted on the basis of higher queued interconnection requests and the upgrades associated with those higher queued interconnection requests being placed in service.

Additional Required Network Upgrades

Certain Network Upgrades that are not the cost responsibility of the Customer are required for Interconnection. These Network Upgrades include:

1. Hitchland - Woodward 345kV double circuit transmission line,
2. Medicine Lodge – Woodward 345kV double circuit transmission line,
3. Spearville-Clark-Medicine Lodge 345kV double circuit 345kV transmission line
4. Medicine Lodge – Wichita 345kV double circuit 345kV transmission line

These network upgrades are not schedule to be in service until December 31, 2014. Depending upon the status of higher or equally queued customers, the Interconnection Customer's in service date may be delayed until the in service date of these Network Upgrades.

Executive Summary

<OMITTED TEXT> (Customer) has requested a Facility Study under the Southwest Power Pool Open Access Transmission Tariff (OATT) for interconnecting a 197.8 MW wind powered generation facility in Gray County, Kansas to the transmission system of Sunflower Electric Power Corporation (SUNC). The wind powered generation facility studied is comprised of eighty-six (86) Siemens SWT 2.3 MW wind turbines. The wind powered generation facility will interconnect into the planned Gray County 345 kV Substation.

SUNC will add a 345kV breaker and half leg to the ring bus at the planned Gray County substation and terminate the GEN-2010-045 wind farm. No reactor is included. The Interconnection Customer's non shared network upgrades and interconnection facilities are estimated at \$5,000,000.

The Customer will be responsible for reactive power compensation equipment to maintain 95% lagging (providing vars) and 95% leading (absorbing vars) power factor at the point of interconnection.

1. Introduction

<OMITTED TEXT> (Customer) has requested a Facility Study under the Southwest Power Pool Open Access Transmission Tariff (OATT) for interconnecting a 197.8 MW wind powered generation facility in Gray County, Kansas to the transmission system of Sunflower Electric Power Corporation (SUNC). The wind powered generation facility studied is comprised of eighty-six (86) Siemens SWT 2.3 MW wind turbines. The wind powered generation facility will interconnect into the planned Gray County 345kV Substation.

2. Interconnection Facilities and Network Upgrades

The cost for the Interconnection Facilities and Network Upgrades is listed below in Table 1. The one-line diagram is shown in Figure 1.

Table 1: Required Interconnection Facilities and Non Shared Network Upgrades

Project	Description	Estimated Cost
1	SUNC-add 345kV breaker and half leg to the ring bus at the planned Gray County substation, and terminate GEN-2010-045 wind farm. No reactor included.	\$5,000,000
	Total:	\$5,000,000

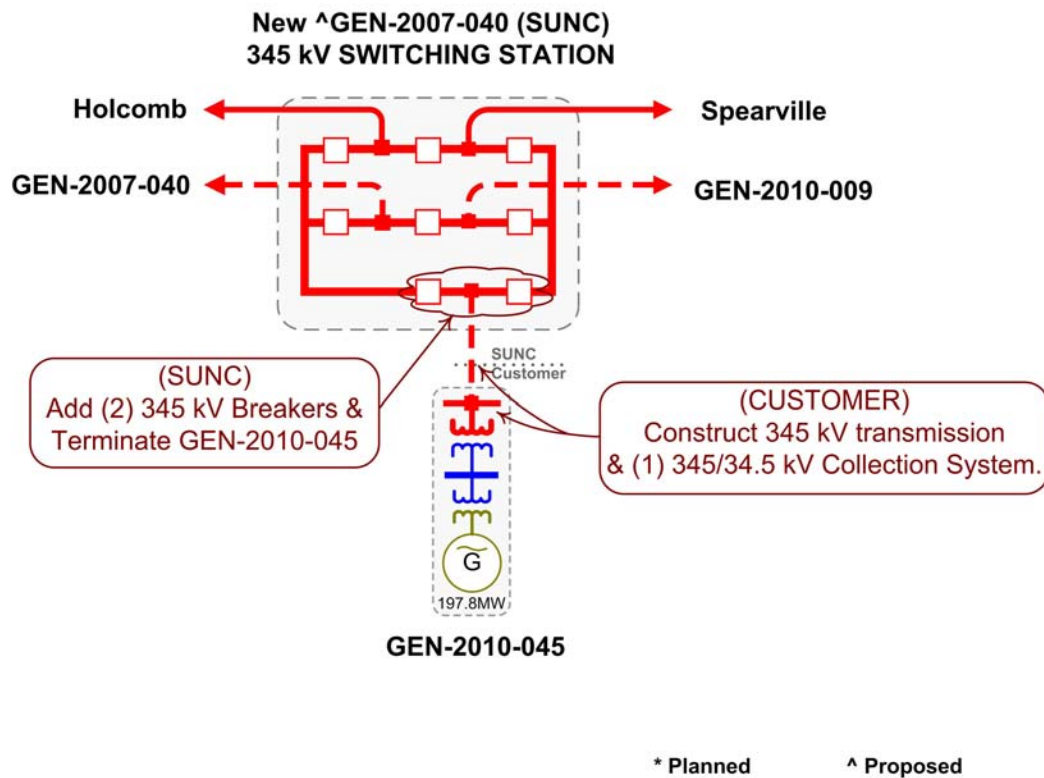

Figure 1. Interconnection Configuration for GEN-2010-045

2.1. Customer Facilities – The Customer will be responsible for its Generating Facility and its 345/34.5 kV substation that will contain its 345/34.5 kV transformer(s) and wind turbine collector feeders. In addition, the Customer will be required to install the following equipment in its facilities.

2.1.1. Reactive Power Equipment – The Customer will be responsible for reactive power compensation equipment to maintain 95% lagging (providing vars) and 95% leading (absorbing vars) power factor at the point of interconnection. Any capacitor banks installed by the Interconnection Customer shall not cause voltage distortion in accordance with Article 9.7.4 of the standard SPP Generation Interconnection Agreement.

3. Conclusion

The Interconnection Customer's interconnection facilities are estimated at \$5,000,000.