



***Facility Study  
For  
Generation Interconnection  
Request  
GEN-2010-058***

***SPP Generation  
Interconnection***

***(#GEN-2010-058)***

**December 2011**

## **Summary**

Xcel Energy Inc. (Xcel) performed a detailed Facility Study at the request of Southwest Power Pool (SPP) for Generation Interconnection request GEN-2010-058 (20 MW). The request for interconnection was placed with SPP in accordance with SPP's Open Access Transmission Tariff, which covers new generation interconnections on SPP's transmission system.

## **Interconnection Customer Interconnection Facilities**

The Interconnection Customer will be responsible for the 115 kV transmission line from its solar Collector Substation to the Point of Interconnection (POI), the Chaves County 115kV. In addition, the customer will be responsible for reactive power compensation equipment to maintain 95% lagging (providing vars) and 95% leading (absorbing vars) power factor at the point of interconnection.

## **Transmission Owner Interconnection Facilities and Non-Shared Network Upgrades**

Per the following Facility Study, the Interconnection Customer is responsible for **\$1,206,694** of Transmission Owner Interconnection Facilities and non-shared network upgrades.

## **Shared Network Upgrades**

The interconnection customer was studied within the DISIS-2011-001 Impact Study. At this time, the Interconnection Customer is allocated \$0 for shared network upgrades. If higher queued interconnection customers withdraw from the queue, suspend or terminate their GIA, restudies will have to be conducted to determine the Interconnection Customers' allocation of shared network upgrades. All studies have been conducted on the basis of higher queued interconnection requests and the upgrades associated with those higher queued interconnection requests being placed in service.

## **Additional Required Network Upgrades**

Certain Network Upgrades that are not the cost responsibility of the Customer are required for Interconnection. These Network Upgrades include:

1. Hitchland - Woodward 345kV double circuit transmission line,
2. Tuco – Woodward 345kV transmission line

These network upgrades are not schedule to be in service until June 30, 2014. Depending upon the status of higher or equally queued customers, the Interconnection Customer's in service date may be delayed until the in service date of these Network Upgrades.



**Facilities Study For  
Southwest Power Pool (SPP)**  
20 MW GCL-SR Solar Energy  
Chaves County, New Mexico  
SPP #GEN-2010-058

October 28, 2011

Xcel Energy Services, Inc.  
Transmission Planning

## Executive Summary

[omitted text] (“Interconnection Customer”) in 2011 requested the interconnection of a solar energy facility located in Chaves County, New Mexico to the Southwestern Public Service Company (SPS), transmission network. SPS is a New Mexico Corporation and wholly owned subsidiary of Xcel Energy Inc. This facility has a net capacity of 20 MW. The Interconnection Customer’s facility will connect to an existing SPS Chaves County Interchange on the 115 kV, which is located approximately 3.5 miles northeast of Roswell, New Mexico. The Solar Farm is across the street to the west of Chaves County Interchange. The Interconnection Customer’s expected commercial operation date is December 31, 2014.

The Southwest Power Pool (SPP) evaluated the request to interconnect the solar farm facility to the SPS transmission system in a Definitive Interconnection System Impact Study (DISIS)-2011-001 for GEN-2010-020 completed in July 2011. The interconnection request was studied using forty (40) Emerson Model SPV-900 rated at 500 kW each for a total output of 20 MW at their substation, which will have one (1) 20/25 MVA 115/12.47 kV transformer. The Interconnection Customer is required to build 115 kV transmission line from their solar farm’s substation to the SPS 115 kV at Chaves Interchange. The Interconnection Customer is required to maintain a Power Factor of 0.95 lagging and 0.95 leading at the Point of Interconnection (POI), based on SPP’s DISIS-2011-001 for Cluster Group 6. The customer is required to add the capacitor banks on the 12.47 kV side of their collector’s 115/12.47 kV transformer. The customer shows a 1.8 MVAR capacitor bank on their one line diagram and SPP shows a 7.2 MVAR capacitor in Table 4-2 “Power Factor Requirements”.

SPS requires that all construction for this request be in compliance with the latest revision of the Xcel Energy Interconnection Guidelines for Transmission Interconnection Producer-Owned Generation 20 MW or less, available at:

([http://www.xcelenergy.com/Energy\\_Partners/Generation\\_Owners/Interconnection\\_Guidelines/Interconnections\\_for\\_Transmission](http://www.xcelenergy.com/Energy_Partners/Generation_Owners/Interconnection_Guidelines/Interconnections_for_Transmission)). This document describes the requirements for connecting new generation to the Xcel Energy transmission systems including technical, protection, commissioning, operation, and maintenance. This document also has a section on Frequency and Frequency Control for the SPP Region on page 21, under SPP criteria, to open tie lines at 58.5 Hz and automatically trip generators. Due to the structure of the under-frequency load-shedding plan, it is necessary that generators be able to sustain frequencies to at least 58.5 Hz. SPS will also require that the Interconnection Customer be in compliance with all applicable criteria, guidelines, standards, requirements, regulations, and procedures issued by the North American Electric Reliability Corporation (NERC), Southwest Power Pool (SPP), and the Federal Energy Regulatory Commission (FERC) or their successor organizations.

The Interconnection Customer is responsible for the cost of the Interconnection Facilities, installation of capacitor banks required and any Direct Assigned Interconnection Facilities; inclusive of all construction required for the 115 kV transmission line from the Interconnection Customer’s substation to Chaves County Interchange.

As for this request (GEN-2010-058), it is anticipated that the entire process of adding a new 115 kV breaker at Chaves County Interchange for the acceptance of the solar farm facility output, will require approximately 15 months to complete after an Interconnection Agreement is signed and an authorization to proceed is received.

The cost of these upgrades, inclusive of the Interconnection Customer’s cost for the interconnection of this solar farm facility, is shown below in Table 1, with the detailed description of the cost shown in Table 3.

**Table 1, Cost Summary<sup>1</sup>**

	Interchange
Network Upgrades:	<b>\$ 51,000</b>
Interconnection Facilities <sup>2</sup> :	<b>\$1,155,694</b>
<b>Total:</b>	<b>\$1,206,694</b>

<sup>1</sup> The cost estimates are 2011 dollars with an accuracy level of ±20%.

<sup>2</sup> This is a direct assigned cost to the Interconnection Customer.

## General Description of SPS Facilities<sup>3</sup>

1. **Construction of New Line Terminal:** See Appendix A, Figure A-1 for general vicinity location map.
  - 1.1. **Location:** SPS will add a 115 kV breaker to a Breaker and Half bus configuration at Chaves County Interchange. Appendix A, Figure A-2, shows a preliminary one-line, while Appendix A, Figure A-3, shows typical elevation view of the Point of Interconnection (POI).
  - 1.2. **Bus Design:** The new 115 kV breaker at Chaves County Interchange will be added to accommodate the output from the solar energy facility.
  - 1.3. **Line Terminals:** The 115 kV lines and static wire terminals will be designed to accommodate 2,000 pounds per phase conductor at maximum tension, with a maximum 15-degree pull off from normal.
  - 1.4. **Control House:** The existing control house will be utilized to house the new metering, protective relaying and control devices, terminal cabinets, and any fiber-optic cable terminations, etc. for the new 115 kV breaker terminals.
  - 1.5. **Security Fence:** The existing security fence shall be extended if required when the new bay is added for the new 115 kV line terminal.
  - 1.6. **Ground Grid:** The existing ground grid shall be extended to accommodate the additional bay if required for the new line terminal per ANSI/IEEE STD 80-1986, with our standard 4/0 copper ground mesh on 40-foot centers with ground rods and 20-foot centers in corners and loop outside of fence.
  - 1.7. **Site Grading:** Company contractor, per company specifications, will perform any site grading and erosion control to accommodate the new line terminal. Soil compaction shall be not less than 95% of laboratory density as determined by ASTM-D-698.
  - 1.8. **Station Power:** The existing station power, provided from the local distribution system, will be utilized.
  - 1.9. **Relay and Protection Scheme:** The new 115 kV breaker line terminal primary and back-up protection to the interconnection customer's 115 kV transmission line will use dual microprocessor step-distance relaying. This relaying is subject to change. An optical fiber installed in the static of the customer's 115 kV transmission line will be required for relay communications.

An SEL DTA-2 will display the bus voltage, GCB amps, MW, MVAR, and fault location.

---

<sup>3</sup> All modifications to SPS facilities will be owned, maintained and operated by SPS.

- 1.10. **Revenue Metering:** On the existing SPS Chaves County Interchange 115 kV line terminal at the Customer's Point of Interconnection, an individual billing meter will be installed along with a meter per ANSI C12.1 accuracy class 0.2 (3-PT's IEEE C57.13 accuracy class 0.3 and 3 CT's IEEE C57.13 accuracy class 0.15) for full 3-phase 4-wire metering. Also installed for the metering units will be 3-PT's and 3-CT's for full 3-phase 4-wire metering. There will be two meters per line terminal: one will be primary and the other will be back up, each will have full 4 quadrant metering. Pulses out of the primary billing meter will be sent via SCADA to the Transmission Owner's Control Center in Amarillo, Texas.
- 1.11. **Disturbance Monitoring Device:** A Disturbance-Fault Recorder (DFR), capable of recording faults, swings, and long term trending, will be installed to monitor and record conditions in the substation and on the transmission lines. The disturbance equipment shall also be equipped with a GPS time synch clock. This equipment will have communication capability with a dedicated communication circuit. The disturbance equipment will have its own dedicated dial-up communications telephone circuit.
- 1.12. **Remote Terminal Unit (RTU):** The existing RTU will be utilized to accommodate the new 115 kV line terminals at Chaves County Interchange. SPS will provide and install if needed additional RTU cards for metering and telemetry as required by the latest Xcel Energy Interconnection Guidelines. The direct cost will be charged to the Interconnection Customer.



- 1.13. **Communications:** To meet its Communications obligations, the Interconnection Customer shall be responsible for making arrangements with the local phone company to provide telephone circuits as required by the Transmission Owner. Transmission Owner equipment may include, but is not limited to, the following: relay communication equipment, RTU, and disturbance monitoring equipment at the new Switching Station. Prior to any construction, the Interconnection Customer is required to contact the Transmission Owner substation-engineering department for all communication details.

The following communications schematic diagram, which includes communication equipment information for the Interconnection Customer, Transmission Provider (Southwest Power Pool) and Transmission Owner (Southwestern Public Service), is provided to assist the Parties.

A schematic outlining the proposed communications is provided below:

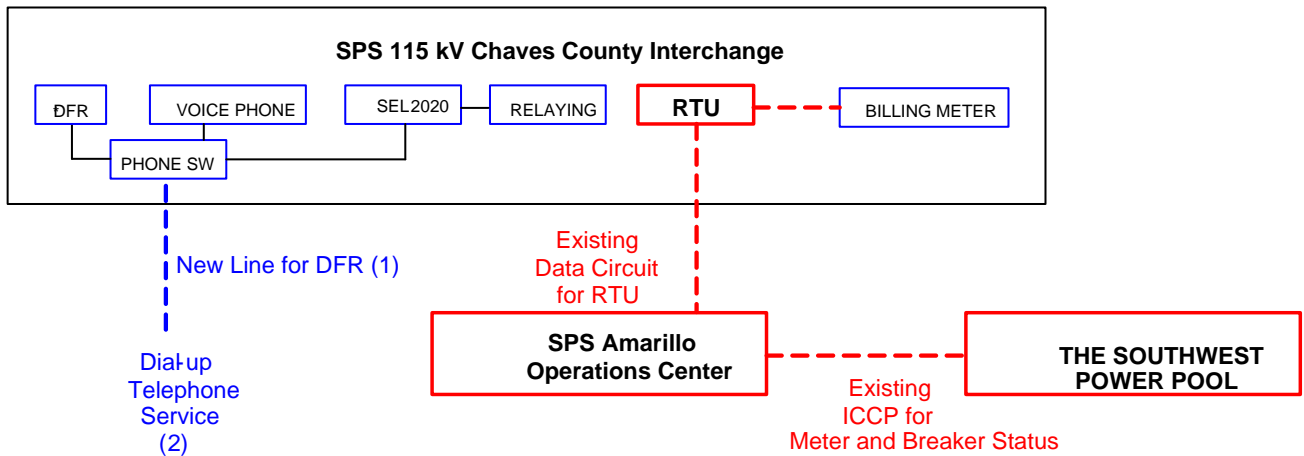

The Interconnection Customer shall be responsible for providing fiber optic communication circuit installed in their overhead transmission line static wire for protective relaying from the customer substation to Chaves County Interchange indicated in Section 1.9.

## 2. Transmission Work:

- 2.1. The Interconnection Customer will construct, own, operate, and maintain any customer owned 115 kV transmission line from the Interconnection Customer's substation to the Point of Interconnection at Chaves County Interchange located approximately 150 meters west of customer's substation as shown in Appendix A, Figure A-1. ***The SPS transmission design group prior to any construction by the Interconnection Customer or its contractor on any customer 115 kV transmission lines, or doing work in close proximity to any SPS transmission line, will require an engineering review of the customer's design. The customer needs to route their 115 kV line to enter SPS Chaves County Interchange from the south to avoid crossing any SPS transmission lines. It is the Interconnection Customer's responsibility to initiate the design review in a timely manner before construction of any transmission line begins. If the review has not been made or the design at any of the aforementioned locations is deemed inadequate, the crossing(s) and or termination into the SPS Chaves County Interchange will be delayed until the matters are resolved. SPS will not be held responsible for these delays.***

## 3. Right-Of-Way and Permits:

- 3.1. **Permitting:** Permitting for the construction of a new 115 kV line terminal at Chaves County Interchange is not required from the Public Utility Commission in the State of New Mexico. The interconnection customer will be responsible for any permitting and right of way of their substation and the 115 kV transmission line from their substation to Chaves County Interchange located northeast of Roswell, New Mexico.

4. **Construction Power and Distribution Service:** It is the sole responsibility of the Interconnection Customer to make arrangements for both construction and station power, which may be required for the Interconnection Customer's solar farm facility. **Additionally, if the Interconnection Customer's substation(s) and/or construction site(s) are located outside of the SPS service area, SPS cannot provide station power (retail distribution service) and the Interconnection Customer needs to make arrangements for distribution service from the local retail provider.**

## 5. Project and Operating Concerns:

- 5.1. Close work between the Transmission group, the Interconnection Customer's personnel and local operating groups will be imperative in order to meet any in-service date that has been established.
- 5.2. It is understood that any Capacitor Bank will be installed at the Interconnection Customer's 12.47 bus to avoid voltage spikes on the 115 kV that adversely affects the Xcel Energy transmission system. See the latest revision of the Xcel Energy Interconnection Guidelines for Transmission Interconnection Producer-Owned Generation for 20 MW or less.

6. **Fault Current Study:** The available fault current at the interconnection location, without any contribution from the solar farm facilities, is shown in Table 2 below.

**Table 2, - Available fault current at Point of Interconnection Location**

Short Circuit Current Availability at Chaves County Interchange without contribution from Solar Farm Facility (GEN 2010-058)				
Fault Location	Fault Current (Amps)		Impedance ( $\Omega$ )	
	Line-to-Ground	3-Phase	$Z^+$	$Z^0$
115 kV Bus	6,073	5,383	1.492 +j12.24	0.511 +j8.135

## Estimated Construction Costs

The projects required for the interconnection of this 20 MW Solar Farm facility consist of the projects summarized in the table below.

**Table 3, Required Interconnection Projects**

Project	Description	Estimated Cost <sup>4</sup>
<b>Network Upgrades</b>		
1	Disturbance Monitoring Device	\$ 51,000
2	Transmission Line Work	\$ 0
3	Right of Way	\$ 00
<b>Subtotal:</b>		<b>\$ 51,000</b>
<b>Transmission Owner Interconnection Facilities (at the Interconnection Customer's expense)</b>		
4	Communications <sup>5</sup>	\$ See footnote
5	Build 115 kV Breaker.	\$ 919,348
6	Remote Terminal Unit (RTU)	\$ 51,346
7	Revenue metering	\$ 165,000
8	115 kV Line arrestors	\$ 20,000
<b>Subtotal:</b>		<b>\$1,155,694</b>
<b>Total Cost:</b>		<b>\$1,206,694</b>

## Engineering and Construction:

An engineering and construction schedule for the installation of the 115 kV breaker line terminals is estimated at approximately 15 months. Other factors associated with clearances, equipment delays and work schedules could cause additional delays. The estimated time (15 months) is applicable after all required agreements are signed and internal approvals are granted.

ID	Task Name	Duration	Start	Finish	2012	2013
1	Chaves Solar Gen 2010-058	315 days?	Mon 4/2/12	Fri 6/14/13	Jan   Feb   Mar   Apr   May   Jun   Jul   Aug   Sep   Oct   Nov   Dec	Jan   Feb   Mar   Apr   May   Jun   Jul   Aug
2	Engineering activities	5.5 mons	Mon 4/2/12	Fri 8/31/12	4/2	8/31
3	Material Procurement	128 days?	Tue 9/4/12	Thu 2/28/13	9/4	2/28
4	115 kV Terminal	15 wks	Mon 3/4/13	Fri 6/14/13	3/4	6/14

All additional cost for work not identified in this study is the sole responsibility of the Interconnection Customer unless other arrangements are made.

<sup>4</sup> The cost estimates are 2011 dollars with an accuracy level of ±20%.

<sup>5</sup> If necessary, It is the Requester's responsibility to provide both the data circuit and both dial-up telephone circuits, see Section 1.13.

**Appendix A (next page)**

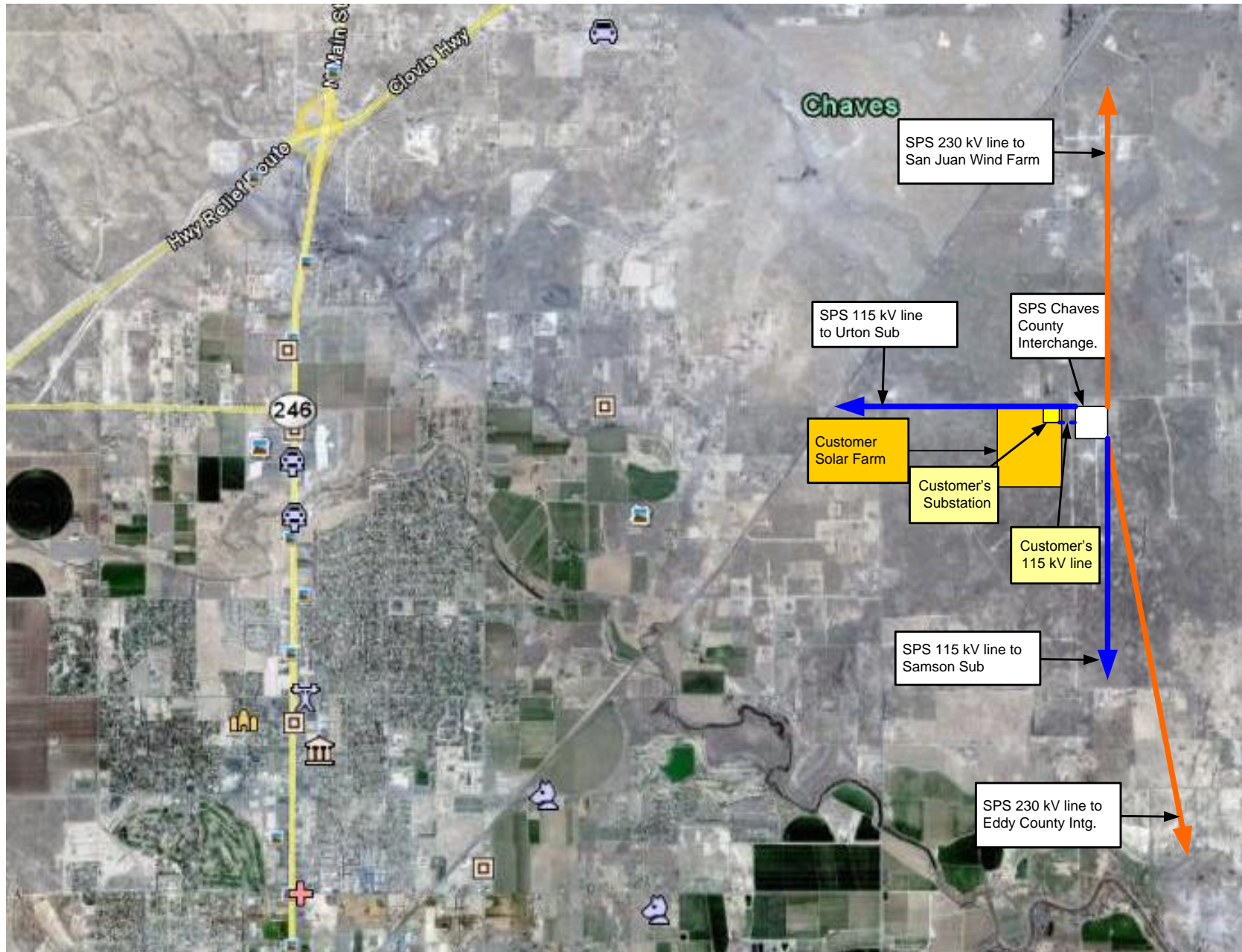

**Figure A-1. Approximate location of proposed Solar Farm Facility and Interconnection Customer's 115 kV Transmission Line.**

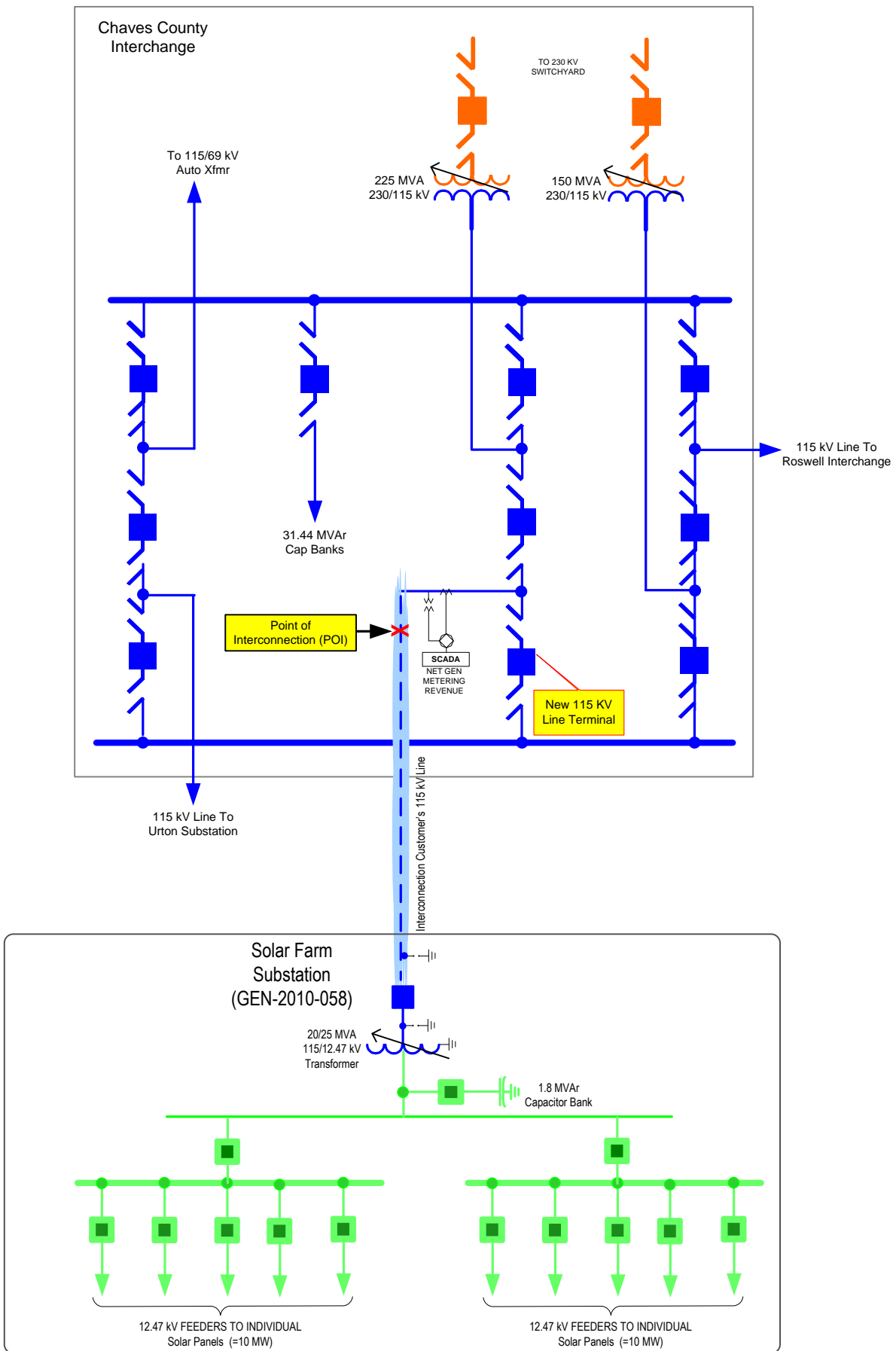

**Figure A- 1 One-line Diagram of Chaves County Interchange**

CUSTOMER SHALL PROVIDE ALL MATERIAL FOR DEAD ENDING PHASES AND STATIC TO 115 kV DEAD END TOWER. DEMONSTRATION PURPOSES.

Customer's Responsibility

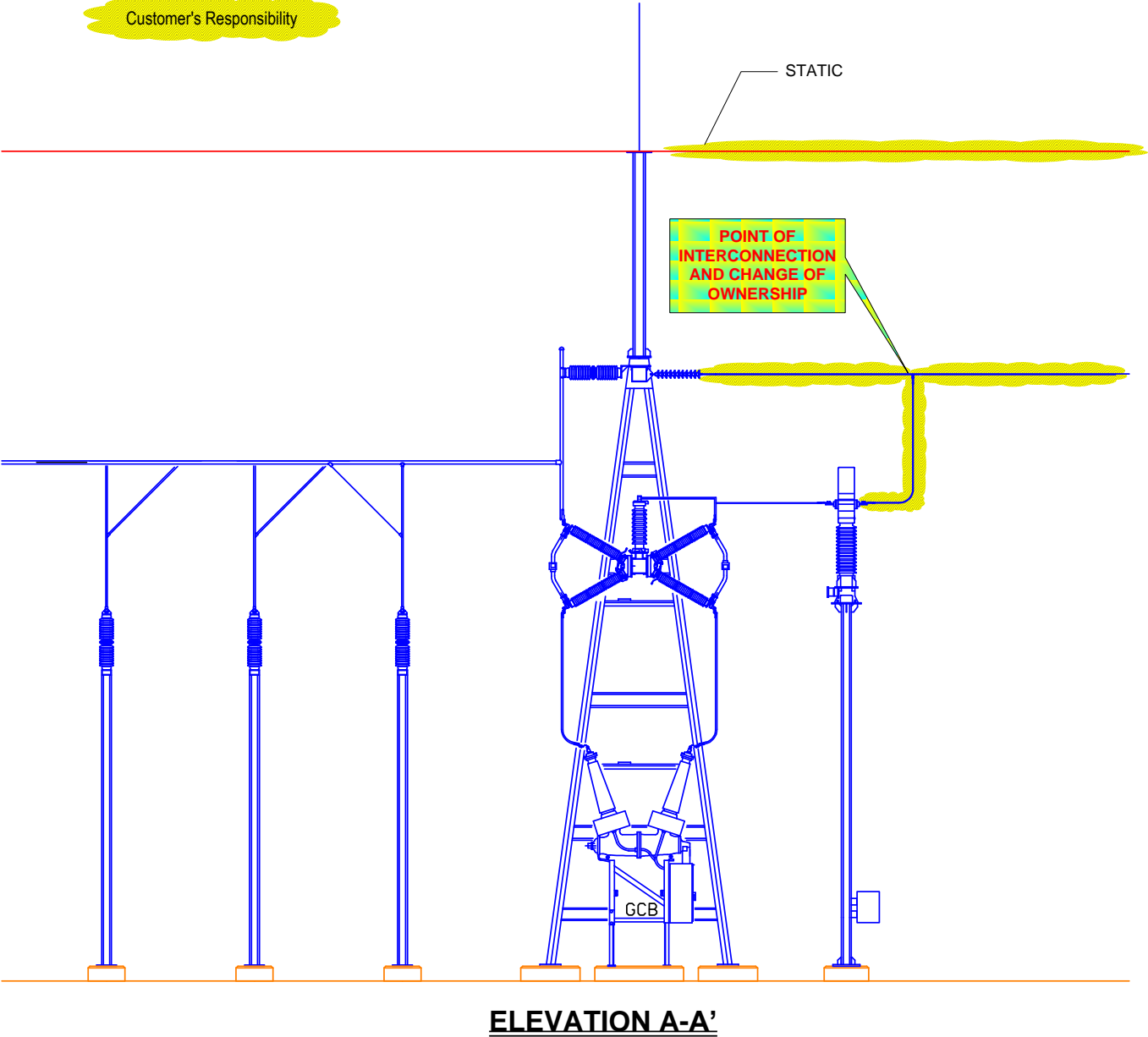

Figure A-3 Point of Interconnection & Change of Ownership (Typical)



*– END OF REPORT –*