



***Limited Operational
Impact Study
For
Generation Interconnection
Request
GEN-2010-045***

***SPP Generation
Interconnection***

(#GEN-2010-045)

May 2011

Executive Summary

<OMITTED TEXT> (Customer) has requested a Limited Operation Impact Study under the Southwest Power Pool Open Access Transmission Tariff (OATT) for interconnection of 197.8 MW of wind generation within the balancing authority of Sunflower Electric Power Corp. (SUNC) in Ford County, Kansas. Customer has requested this Limited Operation Interconnection Study (LOIS) to determine the impacts of interconnecting its generating facility to the transmission system before all required Network Upgrades identified in the DISIS-2010-002 Impact Study can be placed into service. Limited Operation Studies are conducted under GIA Section 5.9.

This study assumed that only the higher queued projects identified in Table 4 of this study might go into service before the completion of all Network Upgrades identified in DISIS-2010-002. If any additional generation projects not identified in Table 4 but with queue priority equal to or over GEN-2010-045 request to go into commercial operation before all Network Upgrades identified through the DISIS-2010-002 study process as required, then this study must be conducted again to determine whether sufficient limited interconnection capacity exists to interconnect the GEN-2010-045 interconnection request in addition to all higher priority requests in operation or pending operation. These projects are listed in Table 5.

Power flow and Stability analysis showed that the Customer's wind facility cannot interconnect until the Balanced Portfolio Project, Spearville-Post Rock 345kV Line, is in-service.

Power flow analysis was based on both summer and winter peak conditions and light loading cases.

The wind generation facility was studied with eighty-six (86) Siemens 2.3 MW wind turbine generators. This Impact study addresses the dynamic stability effects of interconnecting the plant to the rest of the SUNC transmission system for the system condition as it will be on June 1, 2012. Two seasonal base cases were used in the study to analyze the stability impacts of the proposed generation facility. The cases studied were modified 2011 summer peak and 2011 winter peak cases that were adjusted to reflect system conditions at the requested in-service date. Each case was modified to include prior queued projects that are listed in the body of the report. Fifty-five (55) contingencies were identified for use in this study. The Siemens 2.3 MW wind turbines were modeled using information provided by the Customer.

Nothing in this study should be construed as a guarantee of transmission service. If the customer wishes to sell power from the facility, a separate request for transmission service shall be requested on Southwest Power Pool's OASIS by the Customer.

1.0 Introduction

<OMITTED TEXT> (Customer) has requested an Impact Study under the Southwest Power Pool Open Access Transmission Tariff (OATT) for interconnection of 197.8 MW of wind generation within the balancing authority of Sunflower Electric Power Corp. (SUNC) in Ford County, Kansas. Customer has requested this Limited Operation Interconnection Study (LOIS) to determine the impacts of interconnecting its generating facility to the transmission system before all required Network Upgrades identified in the DISIS-2010-002 Impact Study can be placed into service. Limited Operation Studies are conducted under GIA Section 5.9.

This Impact study addresses the dynamic stability effects of interconnecting the plant to the rest of the SUNC transmission system for the system condition as it will be on June 1, 2012. The wind generation facility was studied with eighty-six (86) Siemens 2.3 MW wind turbine generators. Two seasonal base cases were used in the study to analyze the stability impacts of the proposed generation facility. The cases studied were modified versions of the 2011 summer peak and 2011 winter peak to reflect the system conditions at the requested in-service date. Each case was modified to include prior queued projects that are listed in the body of the report. Fifty-five (55) contingencies were identified for this study.

2.0 Purpose

The purpose of this Limited Operation Interconnection Study (LOIS) is to evaluate the impact of the proposed interconnection on the reliability of the Transmission System. The LOIS considers the Base Case as well as all Generating Facilities (and with respect to (b) below, any identified Network Upgrades associated with such higher queued interconnection) that, on the date the LOIS is commenced:

- a) are directly interconnected to the Transmission System;
- b) are interconnected to Affected Systems and may have an impact on the Interconnection Request;
- c) have a pending higher queued Interconnection Request to interconnect to the Transmission System listed in Table 4; or
- d) have no Queue Position but have executed an LGIA or requested that an unexecuted LGIA be filed with FERC.

Any changes to these assumptions, for example, one or more of the previously queued projects not included in this study signing an interconnection agreement, may require a re-study of this request at the expense of the customer.

Nothing in this System Impact Study constitutes a request for transmission service or confers upon the Interconnection Customer any right to receive transmission service.

3.0 Facilities

3.1 Generating Facility

The project was modeled as equivalent wind turbine generators of 101.2 MW and 96.6 MW output. The wind turbines are connected to equivalent 0.69/34.5KV generator step units (GSU). The high side of each GSU is connected to the 34.5/345kV substation transformer. A 345kV transmission line connects the Customer's substation transformer to the POI.

3.2 Interconnection Facility

The Point of Interconnection will be at a tap on the Transmission Owners Holcomb-Spearville 345kV transmission line. Figure 1 shows the proposed POI. Figure 2 shows the Point of Interconnection.

Cost to interconnect on a Limited basis is estimated at \$4,484,903.

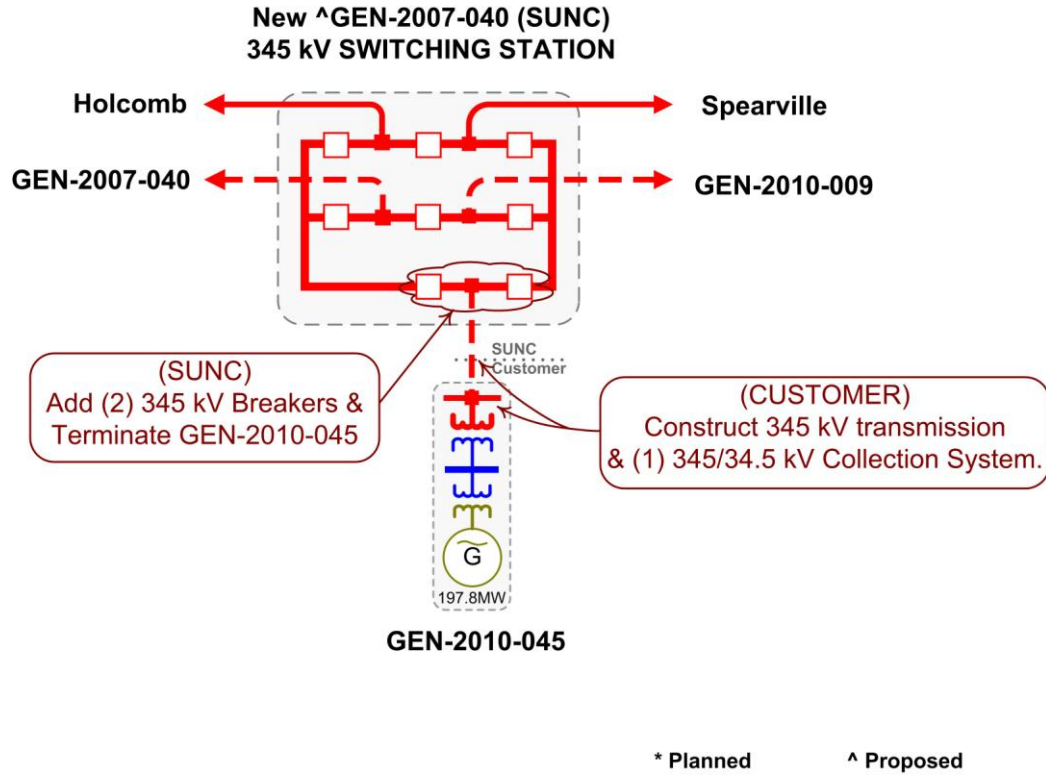

Figure 1: GEN-2010-045 Facility and Proposed Interconnection Configuration

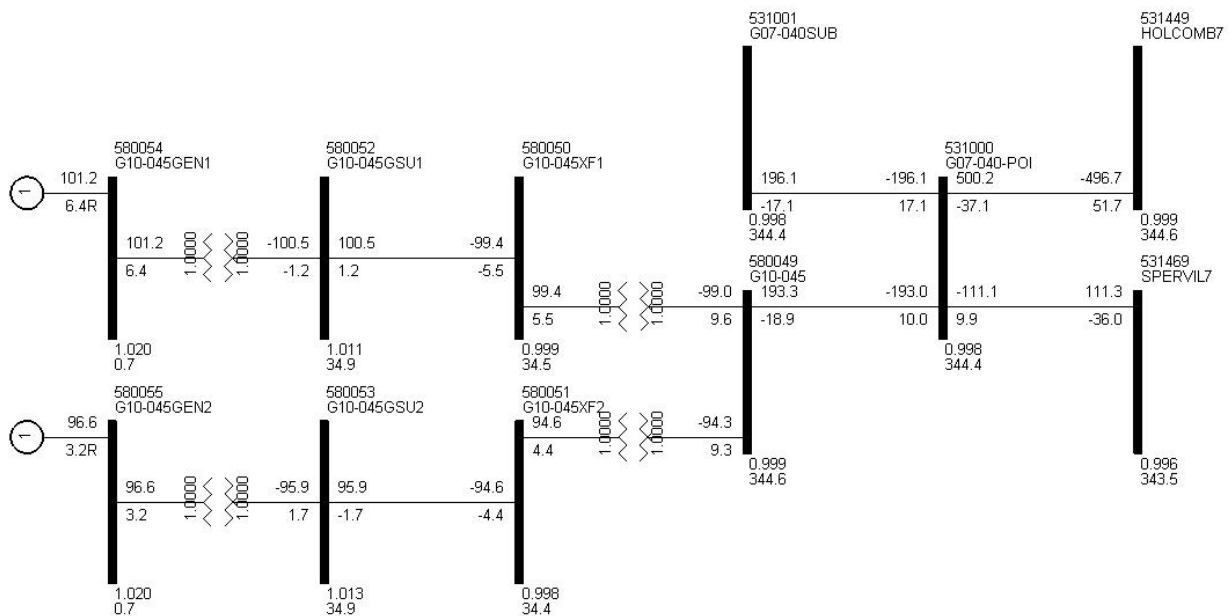

Figure 2: GEN-2010-045 Bus Interconnection

4.0 Power Flow Analysis

A power flow analysis was conducted for the Interconnection Customer's facility using a modified version of the 2011 spring, 2012 summer, and 2012 winter seasonal models. The output of the Interconnection Customer's facility was offset in the model by a reduction in output of existing online SPP generation. This method allows the request to be studied as an Energy Resource (ERIS) Interconnection Request. This analysis was conducted assuming that previous queued requests listed in Table 4 were in-service.

The Southwest Power Pool (SPP) Criteria states that:

“The transmission system of the SPP region shall be planned and constructed so that the contingencies as set forth in the Criteria will meet the applicable NERC Reliability Standards for transmission planning. All MDWG power flow models shall be tested to verify compliance with the System Performance Standards from NERC Table 1 – Category A.”

The ACCC function of PSS/E was used to simulate single contingencies in portions of or all of the control area of SUNC and other control areas within SPP and the resulting data analyzed. This satisfies the “more probable” contingency testing criteria mandated by NERC and the SPP criteria.

Higher queued projects listed in Table 5 were not modeled as in service. If any of these come in service, this study will need to be performed again to determine if any limited interconnection service is available.

The ACCC analysis indicates that as a result of the Customer's project at full nameplate power, possible voltage collapse and other thermal overloads on the SUNC transmission system will occur as shown in Table 1. Table 2 displays ACCC analysis after Balanced Portfolio Project, Spearville-Post Rock 345kV Line, is in-service, which indicates no thermal overloads for this Limited Operation Impact Study.

Table 1: ACCC Analysis without Spearville-PostRock 345kV Ckt 1

SEASON	SOURCE	DIRECTION	MONTCOMMONNAME	RATEA	RATEB	TDF	TC%LOADING	MW Available	CONTNAME
11G	G10_045		NCONV	1102	1328	0.65433	37.05108	0	GRAY CO 345.00 - HOLCOMB 345KV CKT 1
11G	G10_045	FROM->TO	HITCHLAND INTERCHANGE (H TP80148301) 230/115/13.2KV TRANSFORMER CKT 1	250	250	0.19979	122.7983	0	POTTER COUNTY INTERCHANGE (WAUK 90343-A) 345/230/13.2KV TRANSFORMER CKT 1
11G	G10_045	FROM->TO	HITCHLAND INTERCHANGE (H TP80148301) 230/115/13.2KV TRANSFORMER CKT 1	250	250	0.19979	122.7553	0	Hitchland Interchange - POTTER COUNTY INTERCHANGE 345KV CKT 1
12WP	G10_045	FROM->TO	SPEARVILLE (SPEARVL) 345/230/13.8KV TRANSFORMER CKT 1	336	336	0.98571	121.6921	0	GRAY CO 345.00 - HOLCOMB 345KV CKT 1
12SP	G10_045	FROM->TO	SPEARVILLE (SPEARVL) 345/230/13.8KV TRANSFORMER CKT 1	336	336	0.98941	121.2851	0	GRAY CO 345.00 - HOLCOMB 345KV CKT 1
12WP	G10_045	FROM->TO	SPEARVILLE (SPEARVL) 345/230/13.8KV TRANSFORMER CKT 1	336	336	0.98571	120.8804	41.19455	GRAY CO 345.00 - HOLCOMB 345KV CKT 1
12SP	G10_045	FROM->TO	SPEARVILLE (SPEARVL) 345/230/13.8KV TRANSFORMER CKT 1	336	336	0.98941	120.6276	45.6895	GRAY CO 345.00 - HOLCOMB 345KV CKT 1
11G	G10_045	FROM->TO	HITCHLAND INTERCHANGE (H TP80148301) 230/115/13.2KV TRANSFORMER CKT 1	250	250	0.19979	120.4229	46.01438	POTTER COUNTY INTERCHANGE (WAUK 90343-A) 345/230/13.2KV TRANSFORMER CKT 1
11G	G10_045	FROM->TO	HITCHLAND INTERCHANGE (H TP80148301) 230/115/13.2KV TRANSFORMER CKT 1	250	250	0.19979	120.1835	124.0579	Hitchland Interchange - POTTER COUNTY INTERCHANGE 345KV CKT 1
11G	G10_045	TO->FROM	MULLERGREN - SPEARVILLE 230KV CKT 1	330.3	355.3	0.36637	116.1691	125.7166	SPP-SWPS-05
11G	G10_045	TO->FROM	MULLERGREN - SPEARVILLE 230KV CKT 1	330.3	355.3	0.36637	115.7056	126.8248	FINNEY SWITCHING STATION - HOLCOMB 345KV CKT 1
11G	G10_045	TO->FROM	MULLERGREN - SPEARVILLE 230KV CKT 1	330.3	355.3	0.36637	115.6721	127.9494	FINNEY SWITCHING STATION - Hitchland Interchange 345KV CKT 1
12SP	G10_045	FROM->TO	SPEARVILLE (SPEARVL) 345/230/13.8KV TRANSFORMER CKT 1	336	336	0.43713	103.8942	168.0672	FINNEY SWITCHING STATION - Hitchland Interchange 345KV CKT 1
12SP	G10_045	FROM->TO	SPEARVILLE (SPEARVL) 345/230/13.8KV TRANSFORMER CKT 1	336	336	0.43713	103.7469	169.1995	FINNEY SWITCHING STATION - Hitchland Interchange 345KV CKT 1

Table 2: ACCC Analysis with Spearville-PostRock 345kV Ckt 1

SEASON	SOURCE	DIRECTION	MONTCOMMONNAME	RATEA	RATEB	TDF	TC%LOADING	MW Available	CONTNAME
			None						

5.0 Stability Analysis

5.1 Contingencies Simulated

Fifty-five (55) contingencies were considered for the transient stability simulations. These contingencies included three phase faults and single phase line faults at locations defined by SPP. Single-phase line faults were simulated by applying a fault impedance to the positive sequence network at the fault location to represent the effect of the negative and zero sequence networks on the positive sequence network. The fault impedance was computed to give a positive sequence voltage at the specified fault location of approximately 60% of pre-fault voltage. This method is in agreement with SPP current practice.

The faults that were defined and simulated are listed in Table 3 below.

Table 3: Contingencies Evaluated

Cont. No.	Cont. Name	Description
1	FLT01-3PH	3 phase fault on the Woodward (515375) to Tatonga (515407) 345kV line, near Woodward. a. Apply fault at the Woodward 345kV bus. b. Clear fault after 5 cycles by tripping the faulted line.
2	FLT02-1PH	Single phase fault on the line in previous a. Apply single phase fault. b. Clear fault after 5 cycles by tripping the faulted line. c. Wait 20 cycles, and then re-close the line in (b) back into the fault. d. Leave fault on for 5 cycles, then trip the line in (b) and remove fault.
3	FLT03-3PH	3 phase fault on one of the Finney (523853) to Hitchland (523097) 345kV lines, near Finney. a. Apply fault at the Finney 345kV bus. b. Clear fault after 5 cycles by tripping the faulted line.
4	FLT04-1PH	Single phase fault on the line in previous a. Apply single phase fault. b. Clear fault after 5 cycles by tripping the faulted line. c. Wait 20 cycles, and then re-close the line in (b) back into the fault. d. Leave fault on for 5 cycles, then trip the line in (b) and remove fault.
5	FLT05-3PH	3 phase fault on one of the Finney (523853) to Holcomb (531449) 345kV lines, near Finney. a. Apply fault at the Finney 345kV bus. b. Clear fault after 5 cycles by tripping the faulted line.
6	FLT06-1PH	Single phase fault on the line in previous a. Apply single phase fault. b. Clear fault after 5 cycles by tripping the faulted line. c. Wait 20 cycles, and then re-close the line in (b) back into the fault. d. Leave fault on for 5 cycles, then trip the line in (b) and remove fault.

Cont. No.	Cont. Name	Description
7	FLT07-3PH	3 phase fault on the Finney (523853) to Lamar (599950) 345kV line, near Finney. a. Apply fault at Finney (599950) 345kV bus. b. Clear fault after 5 cycles by tripping the faulted line. c. Wait 20 cycles, and then re-close the line in (b) back into the fault. d. Leave fault on for 5 cycles, then trip the line in (b) and remove fault.
8	FLT08-1PH	<i>Single phase fault and sequence like previous</i>
9	FLT09-3PH	3 phase fault on the Post Rock (530584) to South Hays (530582) 230kV line, near Post Rock. a. Apply fault at the Post Rock 230kV bus. b. Clear fault after 5 cycles by tripping the faulted line. c. Wait 20 cycles, and then re-close the line in (b) back into the fault. d. Leave fault on for 5 cycles, then trip the line in (b) and remove fault.
10	FLT10-1PH	<i>Single phase fault and sequence like previous</i>
11	FLT11-3PH	3 phase fault on the Knoll (530558) to Smoky Hills (530592) 230kV line, near Knoll. a. Apply fault at the Knoll 230kV bus. b. Clear fault after 5 cycles by tripping the faulted line. c. Wait 20 cycles, and then re-close the line in (b) back into the fault. d. Leave fault on for 5 cycles, then trip the line in (b) and remove fault.
12	FLT12-1PH	<i>Single phase fault and sequence like previous</i>
13	FLT13-3PH	3 phase fault on the Holcomb (531449) to GEN-2007-040 (531000) 345kV line, near GEN-2007-040. a. Apply fault at the GEN-2007-040 345kV bus. b. Clear fault after 5 cycles by tripping the faulted line.
14	FLT14-1PH	Single phase fault on the line in previous a. Apply single phase fault. b. Clear fault after 5 cycles by tripping the faulted line. c. Wait 20 cycles, and then re-close the line in (b) back into the fault. d. Leave fault on for 5 cycles, then trip the line in (b) and remove fault.
15	FLT15-3PH	3 phase fault on the Spearville (531469) to GEN-2007-040 (531000) 345kV line, near GEN-2007-040. a. Apply fault at the GEN-2007-040 345kV bus. b. Clear fault after 5 cycles by tripping the faulted line. c. Wait 20 cycles, and then re-close the line in (b) back into the fault. d. Leave fault on for 5 cycles, then trip the line in (b) and remove fault.
16	FLT16-1PH	<i>Single phase fault and sequence like previous</i>
17	FLT17-3PH	3 phase fault on the Pioneer (531391) to Hickock (531378) 115kV line, near Pioneer. a. Apply fault at the Pioneer 115kV bus. b. Clear fault after 5 cycles by tripping the faulted line. c. Wait 20 cycles, and then re-close the line in (b) back into the fault. d. Leave fault on for 5 cycles, then trip the line in (b) and remove fault.
18	FLT18-1PH	<i>Single phase fault and sequence like previous</i>
19	FLT19-3PH	3 phase fault on the Pioneer (531391) to PK Goab (531400) 115kV line, near Pioneer. a. Apply fault at the Pioneer 115kV bus. b. Clear fault after 5 cycles by tripping the faulted line. c. Wait 20 cycles, and then re-close the line in (b) back into the fault. d. Leave fault on for 5 cycles, then trip the line in (b) and remove fault.

Cont. No.	Cont. Name	Description
20	FLT20-1PH	<i>Single phase fault and sequence like previous</i>
21	FLT21-3PH	3 phase fault on the Holcomb 345kV (531449) to 115kV (531448) transformer, near the 345 kV bus. a. Apply fault at the Holcomb 345kV bus. b. Clear fault after 5 cycles by tripping the faulted transformer.
22	FLT23-3PH	3 phase fault on the Holcomb (531449) to Setab (531465) 345kV line, near Holcomb. a. Apply fault at the Holcomb 345kV bus. b. Clear fault after 5 cycles by tripping the faulted line.
23	FLT24-1PH	Single phase fault on the line in previous a. Apply single phase fault. b. Clear fault after 5 cycles by tripping the faulted line. c. Wait 20 cycles, and then re-close the line in (b) back into the fault. d. Leave fault on for 5 cycles, then trip the line in (b) and remove fault.
24	FLT25-3PH	3 phase fault on the Spearville 345kV (531469) to 230kV (539695) transformer, near the 345 kV bus. a. Apply fault at the Spearville 345kV bus. b. Clear fault after 5 cycles by tripping the faulted transformer.
25	FLT27-3PH	3 phase fault on the Hugoton (531481) to Walkmyr (531405)115kV line, near Hugoton. a. Apply fault at the Hugoton 115kV bus. b. Clear fault after 5 cycles by tripping the faulted line. c. Wait 20 cycles, and then re-close the line in (b) back into the fault. d. Leave fault on for 5 cycles, then trip the line in (b) and remove fault.
26	FLT28-1PH	<i>Single phase fault and sequence like previous</i>
27	FLT29-3PH	3 phase fault on the Hugoton (531481) to Grant Tap (531483)115kV line, near Hugoton. a. Apply fault at the Hugoton 115kV bus. b. Clear fault after 5 cycles by tripping the faulted line. c. Wait 20 cycles, and then re-close the line in (b) back into the fault. d. Leave fault on for 5 cycles, then trip the line in (b) and remove fault.
28	FLT30-1PH	<i>Single phase fault and sequence like previous</i>
29	FLT31-3PH	3 phase fault on the Kismet (539646) to CMRIVTP (539652) 115kV line, near Kismet. a. Apply fault at the Kismet 115kV bus. b. Clear fault after 5 cycles by tripping the faulted line. c. Wait 20 cycles, and then re-close the line in (b) back into the fault. d. Leave fault on for 5 cycles, then trip the line in (b) and remove fault.
30	FLT32-1PH	<i>Single phase fault and sequence like previous</i>
31	FLT33-3PH	3 phase fault on the Kismet (539646) to Cudahy (539659) 115kV line, near Kismet. a. Apply fault at the Kismet 115kV bus. b. Clear fault after 5 cycles by tripping the faulted line. c. Wait 20 cycles, and then re-close the line in (b) back into the fault. d. Leave fault on for 5 cycles, then trip the line in (b) and remove fault.
32	FLT34-1PH	<i>Single phase fault and sequence like previous</i>

Cont. No.	Cont. Name	Description
33	FLT35-3PH	3 phase fault on the CMRIVTP (539652) to E-Liber (539672) 115kV line, near CMRIVTP. a. Apply fault at the CMRIVTP 115kV bus. b. Clear fault after 5 cycles by tripping the faulted line. c. Wait 20 cycles, and then re-close the line in (b) back into the fault. d. Leave fault on for 5 cycles, then trip the line in (b) and remove fault.
34	FLT36-1PH	<i>Single phase fault and sequence like previous</i>
35	FLT37-3PH	3 phase fault on the Cudahy (539659) to GEN-2008-079 (573029) 115kV line, near Cudahy. a. Apply fault at the Cudahy 115kV bus. b. Clear fault after 5 cycles by tripping the faulted line. c. Wait 20 cycles, and then re-close the line in (b) back into the fault. d. Leave fault on for 5 cycles, then trip the line in (b) and remove fault.
36	FLT38-1PH	<i>Single phase fault and sequence like previous</i>
37	FLT39-3PH	3 phase fault on the Medicine Lodge (539673) to Sun City (539697) 115kV line, near Medicine Lodge. a. Apply fault at the Medicine Lodge 115kV bus. b. Clear fault after 5 cycles by tripping the faulted line. c. Wait 20 cycles, and then re-close the line in (b) back into the fault. d. Leave fault on for 5 cycles, then trip the line in (b) and remove fault.
38	FLT40-1PH	<i>Single phase fault and sequence like previous</i>
39	FLT41-3PH	3 phase fault on the Mullergren (539679) to South Hays (530582) 230kV line, near Mullergren. a. Apply fault at the Mullergren 230kV bus. b. Clear fault after 5 cycles by tripping the faulted line. c. Wait 20 cycles, and then re-close the line in (b) back into the fault. d. Leave fault on for 5 cycles, then trip the line in (b) and remove fault.
40	FLT42-1PH	<i>Single phase fault and sequence like previous</i>
41	FLT43-3PH	3 phase fault on the Mullergren (539679) to Circle (532871) 230kV line, near Mullergren. a. Apply fault at the Mullergren 230kV bus. b. Clear fault after 5 cycles by tripping the faulted line. c. Wait 20 cycles, and then re-close the line in (b) back into the fault. d. Leave fault on for 5 cycles, then trip the line in (b) and remove fault.
42	FLT44-1PH	<i>Single phase fault and sequence like previous</i>
43	FLT45-3PH	3 phase fault on the Pratt (539687) to Ninnescah (539648) 115kV line, near Pratt. a. Apply fault at the Pratt 115kV bus. b. Clear fault after 5 cycles by tripping the faulted line. c. Wait 20 cycles, and then re-close the line in (b) back into the fault. d. Leave fault on for 5 cycles, then trip the line in (b) and remove fault.
44	FLT46-1PH	<i>Single phase fault and sequence like previous</i>
45	FLT47-3PH	3 phase fault on the Pratt (539687) to Sawyer (539649) 115kV line, near Pratt. a. Apply fault at the Pratt 115kV bus. b. Clear fault after 5 cycles by tripping the faulted line. c. Wait 20 cycles, and then re-close the line in (b) back into the fault. d. Leave fault on for 5 cycles, then trip the line in (b) and remove fault.
46	FLT48-1PH	<i>Single phase fault and sequence like previous</i>

Cont. No.	Cont. Name	Description
47	FLT49-3PH	3 phase fault on the Spearville (539695) to Mullergren (539679) 230kV line, near Spearville. a. Apply fault at the Spearville 230kV bus. b. Clear fault after 5 cycles by tripping the faulted line. c. Wait 20 cycles, and then re-close the line in (b) back into the fault. d. Leave fault on for 5 cycles, then trip the line in (b) and remove fault.
48	FLT50-1PH	<i>Single phase fault and sequence like previous</i>
49	FLT51-3PH	3 phase fault on the Spearville 230kV (539695) to 115kV (539694) transformer, near the 230 kV bus. a. Apply fault at the Spearville 230kV bus. b. Clear fault after 5 cycles by tripping the faulted transformer.
50	FLT53-3PH	3 phase fault on the GEN-2001-039A (579025) to Fort Dodge (539671) 115kV line, near GEN-2001-039A. a. Apply fault at the GEN-2001-039A 115kV bus. b. Clear fault after 5 cycles by tripping the faulted line. c. Wait 20 cycles, and then re-close the line in (b) back into the fault. d. Leave fault on for 5 cycles, then trip the line in (b) and remove fault.
51	FLT54-1PH	<i>Single phase fault and sequence like previous</i>
52	FLT55-3PH	3 phase fault on the Axtell (640065) to Pauline (640312) 345kV line, near Axtell. a. Apply fault at the Axtell 345kV bus. b. Clear fault after 5 cycles by tripping the faulted line. c. Wait 20 cycles, and then re-close the line in (b) back into the fault. d. Leave fault on for 5 cycles, then trip the line in (b) and remove fault.
53	FLT56-1PH	<i>Single phase fault and sequence like previous</i>
54	FLT57-3PH	3 phase fault on the Axtell (640065) to Sweetwater (640374) 345kV line, near Axtell. a. Apply fault at the Axtell 345kV bus. b. Clear fault after 5 cycles by tripping the faulted line. c. Wait 20 cycles, and then re-close the line in (b) back into the fault. d. Leave fault on for 5 cycles, then trip the line in (b) and remove fault.
55	FLT58-1PH	<i>Single phase fault and sequence like previous</i>

5.2 Further Model Preparation

The base cases contain prior queued projects as shown in Table 4.

The wind generation from the study customer and the previously queued customers were dispatched into the SPP footprint.

Initial simulations were carried out on both base cases and cases with the added generation for a no-disturbance run of 20 seconds to verify the numerical stability of the model. All cases were confirmed to be stable.

Table 4: Prior Queued Projects Included

Project	MW
Montezuma	110
GEN-2002-025A	150
GEN-2006-021	100
GEN-2003-019	250
GEN-2001-039A	105
GEN-2005-012	160
GEN-2008-079	100
GEN-2007-040	200

The projects listed in Table 5 are higher or equally queued projects that are not included in this analysis. If any of these projects come into service, this study will need to be re-performed to determine if any limited capacity is available.

Table 5: Prior Queued Projects Not Included

Project	MW
GEN-2004-014	150
GEN-2005-012	90
GEN-2006-006	205
GEN-2007-038	200
GEN-2008-018	405
GEN-2008-124	200
GEN-2009-062	115
GEN-2010-009	166
GEN-2010-015	200
GEN-2010-016	200
GEN-2010-049	50
GEN-2010-052	301
GEN-2010-053	200

A stability analysis showed that the Customer's wind facility cannot interconnect until the Balanced Portfolio Project, Spearville-Post Rock 345kV Line, is in-service.

5.3 Results

Results of the stability analysis are summarized in Table 6. The results indicate that for all contingencies studied the transmission system remains stable with the Balanced Portfolio Project, Spearville-Post Rock 345kV Line, in-service.

Table 6: Results of Simulated Contingencies

Cont. No.	Cont. Name	Description	Without upgrades		Spearville – Post Rock 345kV in-service	
			2011 Summer	2011 Winter	2011 Summer	2011 Winter
1	FLT01-3PH	3 phase fault on the Woodward (515375) to Tatonga (515407) 345kV line, near Woodward.	Stable	Stable	Stable	Stable
2	FLT02-1PH	Single phase fault on the line in previous	Stable	Stable	Stable	Stable
3	FLT03-3PH	3 phase fault on one of the Finney (523853) to Hitchland (523097) 345kV lines, near Finney.	Stable	Stable	Stable	Stable
4	FLT04-1PH	Single phase fault on the line in previous	Stable	Stable	Stable	Stable
5	FLT05-3PH	3 phase fault on one of the Finney (523853) to Holcomb (531449) 345kV lines, near Finney.	Unstable	Stable	Stable	Stable
6	FLT06-1PH	Single phase fault on the line in previous	Unstable	Stable	Stable	Stable
7	FLT07-3PH	3 phase fault on the Finney (523853) to Lamar (599950) 345kV line, near Finney.	Stable	Stable	Stable	Stable
8	FLT08-1PH	<i>Single phase fault and sequence like previous</i>	Stable	Stable	Stable	Stable
9	FLT09-3PH	3 phase fault on the Post Rock (530584) to South Hays (530582) 230kV line, near Post Rock.	Stable	Stable	Stable	Stable
10	FLT10-1PH	<i>Single phase fault and sequence like previous</i>	Stable	Stable	Stable	Stable
11	FLT11-3PH	3 phase fault on the Knoll (530558) to Smoky Hills (530592) 230kV line, near Knoll.	Stable	Stable	Stable	Stable
12	FLT12-1PH	<i>Single phase fault and sequence like previous</i>	Stable	Stable	Stable	Stable
13	FLT13-3PH	3 phase fault on the Holcomb (531449) to GEN-2007-040 (531000) 345kV line, near GEN-2007-040.	Unstable	Unstable	Stable	Stable
14	FLT14-1PH	Single phase fault on the line in previous	Unstable	Unstable	Stable	Stable
15	FLT15-3PH	3 phase fault on the Spearville (531469) to GEN-2007-040 (531000) 345kV line, near GEN-2007-040.	Stable	Stable	Stable	Stable
16	FLT16-1PH	<i>Single phase fault and sequence like previous</i>	Stable	Stable	Stable	Stable
17	FLT17-3PH	3 phase fault on the Pioneer (531391) to Hickock (531378) 115kV line, near Pioneer.	Stable	Stable	Stable	Stable
18	FLT18-1PH	<i>Single phase fault and sequence like previous</i>	Stable	Stable	Stable	Stable
19	FLT19-3PH	3 phase fault on the Pioneer (531391) to PK Goab (531400) 115kV line, near Pioneer.	Stable	Stable	Stable	Stable
20	FLT20-1PH	<i>Single phase fault and sequence like previous</i>	Stable	Stable	Stable	Stable
21	FLT21-3PH	3 phase fault on the Holcomb 345kV (531449) to 115kV (531448) transformer, near the 345 kV bus.	Stable	Stable	Stable	Stable
22	FLT23-3PH	3 phase fault on the Holcomb (531449) to Setab (531465) 345kV line, near Holcomb.	Stable	Stable	Stable	Stable
23	FLT24-1PH	Single phase fault on the line in previous	Stable	Stable	Stable	Stable

Cont. No.	Cont. Name	Description	Without upgrades		Spearville – Post Rock 345kV in-service	
			2011 Summer	2011 Winter	2011 Summer	2011 Winter
24	FLT25-3PH	3 phase fault on the Spearville 345kV (531469) to 230kV (539695) transformer, near the 345 kV bus.	Stable	Stable	Stable	Stable
25	FLT27-3PH	3 phase fault on the Hugoton (531481) to Walkmyr (531405) 115kV line, near Hugoton.	Stable	Stable	Stable	Stable
26	FLT28-1PH	<i>Single phase fault and sequence like previous</i>	Stable	Stable	Stable	Stable
27	FLT29-3PH	3 phase fault on the Hugoton (531481) to Grant Tap (531483) 115kV line, near Hugoton.	Stable	Stable	Stable	Stable
28	FLT30-1PH	<i>Single phase fault and sequence like previous</i>	Stable	Stable	Stable	Stable
29	FLT31-3PH	3 phase fault on the Kismet (539646) to CMRIVTP (539652) 115kV line, near Kismet.	Stable	Stable	Stable	Stable
30	FLT32-1PH	<i>Single phase fault and sequence like previous</i>	Stable	Stable	Stable	Stable
31	FLT33-3PH	3 phase fault on the Kismet (539646) to Cudahy (539659) 115kV line, near Kismet.	Stable	Stable	Stable	Stable
32	FLT34-1PH	<i>Single phase fault and sequence like previous</i>	Stable	Stable	Stable	Stable
33	FLT35-3PH	3 phase fault on the CMRIVTP (539652) to E-Liber (539672) 115kV line, near CMRIVTP.	Stable	Stable	Stable	Stable
34	FLT36-1PH	<i>Single phase fault and sequence like previous</i>	Stable	Stable	Stable	Stable
35	FLT37-3PH	3 phase fault on the Cudahy (539659) to GEN-2008-079 (573029) 115kV line, near Cudahy.	Stable	Stable	Stable	Stable
36	FLT38-1PH	<i>Single phase fault and sequence like previous</i>	Stable	Stable	Stable	Stable
37	FLT39-3PH	3 phase fault on the Medicine Lodge (539673) to Sun City (539697) 115kV line, near Medicine Lodge.	Stable	Stable	Stable	Stable
38	FLT40-1PH	<i>Single phase fault and sequence like previous</i>	Stable	Stable	Stable	Stable
39	FLT41-3PH	3 phase fault on the Mullergren (539679) to South Hays (530582) 230kV line, near Mullergren.	Stable	Stable	Stable	Stable
40	FLT42-1PH	<i>Single phase fault and sequence like previous</i>	Stable	Stable	Stable	Stable
41	FLT43-3PH	3 phase fault on the Mullergren (539679) to Circle (532871) 230kV line, near Mullergren.	Stable	Stable	Stable	Stable
42	FLT44-1PH	<i>Single phase fault and sequence like previous</i>	Stable	Stable	Stable	Stable
43	FLT45-3PH	3 phase fault on the Pratt (539687) to Ninnescah (539648) 115kV line, near Pratt.	Stable	Stable	Stable	Stable
44	FLT46-1PH	<i>Single phase fault and sequence like previous</i>	Stable	Stable	Stable	Stable
45	FLT47-3PH	3 phase fault on the Pratt (539687) to Sawyer (539649) 115kV line, near Pratt.	Stable	Stable	Stable	Stable
46	FLT48-1PH	<i>Single phase fault and sequence like previous</i>	Stable	Stable	Stable	Stable
47	FLT49-3PH	3 phase fault on the Spearville (539695) to Mullergren (539679) 230kV line, near Spearville.	Stable	Stable	Stable	Stable

Cont. No.	Cont. Name	Description	Without upgrades		Spearville – Post Rock 345kV in-service	
			2011 Summer	2011 Winter	2011 Summer	2011 Winter
48	FLT50-1PH	<i>Single phase fault and sequence like previous</i>	Stable	Stable	Stable	Stable
49	FLT51-3PH	3 phase fault on the Spearville 230kV (539695) to 115kV (539694) transformer, near the 230 kV bus.	Stable	Stable	Stable	Stable
50	FLT53-3PH	3 phase fault on the GEN-2001-039A (579025) to Fort Dodge (539671) 115kV line, near GEN-2001-039A.	Stable	Stable	Stable	Stable
51	FLT54-1PH	<i>Single phase fault and sequence like previous</i>	Stable	Stable	Stable	Stable
52	FLT55-3PH	3 phase fault on the Axtell (640065) to Pauline (640312) 345kV line, near Axtell.	Stable	Stable	Stable	Stable
53	FLT56-1PH	<i>Single phase fault and sequence like previous</i>	Stable	Stable	Stable	Stable
54	FLT57-3PH	3 phase fault on the Axtell (640065) to Sweetwater (640374) 345kV line, near Axtell.	Stable	Stable	Stable	Stable
55	FLT58-1PH	<i>Single phase fault and sequence like previous</i>	Stable	Stable	Stable	Stable

5.4 FERC LVRT Compliance

FERC Order #661A places specific requirements on wind farms through its Low Voltage Ride Through (LVRT) provisions. For Interconnection Agreements signed after December 31, 2006, wind farms shall stay on line for faults at the POI that draw the voltage down at the POI to 0.0 pu.

Two fault contingencies were developed to verify that the wind farm will remain on line when the POI voltage is drawn down to 0.0 pu. These contingencies are shown in Table 7.

Table 7: LVRT Fault Contingencies

Cont. Name	Description
FLT13-3PH	3 phase fault on the Holcomb (531449) to GEN-2007-040 (531000) 345kV line, near GEN-2007-040. a. Apply fault at the GEN-2007-040 345kV bus. b. Clear fault after 5 cycles by tripping the faulted line.
FLT15-3PH	3 phase fault on the Spearville (531469) to GEN-2007-040 (531000) 345kV line, near GEN-2007-040. a. Apply fault at the GEN-2007-040 345kV bus. b. Clear fault after 5 cycles by tripping the faulted line. c. Wait 20 cycles, and then re-close the line in (b) back into the fault. d. Leave fault on for 5 cycles, then trip the line in (b) and remove fault.

The project wind farm remained online for the fault contingencies described in this section and for all the fault contingencies described in section 6.2. GEN-2010-045 is found to be in compliance with FERC Order #661A.

6.0 Conclusion

<OMITTED TEXT> (Customer) has requested an Limited Operation Impact Study for limited interconnection service of 197.8 MW of wind generation within the balancing authority of Sunflower Electric Power Corp (SUNC) in Ford County, Kansas, , in accordance with the Article 5.9 of the Standard Generation Interconnection Agreement (GIA) in the SPP OATT.

The results of this study show that the wind generation facility and the transmission system remain stable for all contingencies studied. Also, GEN-2010-045 is found to be in compliance with FERC Order #661A.

The projects listed in Table 5 are higher or equally queued projects that are not included in this analysis. If any of these projects come into service, this study will need to be re-performed to determine if any limited capacity is available.

Both power flow and stability analysis showed that the Customer's wind facility cannot interconnect until the Balanced Portfolio Project, Spearville-Post Rock 345kV Line, is in-service.

The estimates do not include any costs associated with the deliverability of the energy to final customers. These costs are determined by separate studies if the Customer requests transmission service through Southwest Power Pool's OASIS. It should be noted that the models used for simulation do not contain all SPP transmission service.