



SPP *Southwest
Power Pool*

***Facility Study
For
Generation Interconnection
Request
GEN-2010-007***

***SPP Generation
Interconnection***

(#GEN-2010-007)

April 2011

Summary

Xcel Energy Inc. (Xcel) performed a detailed Facility Study at the request of Southwest Power Pool (SPP) for Generation Interconnection request GEN-2010-007. The interconnection of the 73.8 MW wind energy facility located in Hutchison County, Texas is in the control area of the Southwestern Public Service Company (SPS) transmission network. SPS is a New Mexico Corporation and wholly owned subsidiary of Xcel Energy Inc. The request for interconnection was placed with SPP in accordance with SPP's Open Access Transmission Tariff, which covers new generation interconnections on SPP's transmission system.

Interconnection Customer Interconnection Facilities

The Interconnection Customer will be responsible for the 115 kV transmission line from the Wind turbine Collector Substation to the Point of Interconnection (POI), a new SPS switching station located on the 115 kV line between Pringle Interchange and Riverview Interchange approximately four (4) miles northeast of Stinnett, Texas. In addition, the customer will be responsible for reactive power compensation equipment to maintain 95% lagging (providing vars) and 95% leading (absorbing vars) power factor at the point of interconnection. Any capacitor banks installed by the Customer shall not cause voltage or other distortion on the transmission system in accordance with Article 9.7.6 of the Standard GIA, Power Quality.

Transmission Owner Interconnection Facilities and Non-Shared Network Upgrades

Per the following Facility Study, the Interconnection Customer is responsible for **\$2,867,363** of Transmission Owner Interconnection Facilities and non-shared network upgrades.

Shared Network Upgrades

The interconnection customer was studied within the DISIS-2010-001-1 Impact Restudy. At this time, the Interconnection Customer is allocated the following costs for shared network upgrades:

Upgrade Type	Allocated Costs
Build 105 miles of double circuit 345 kV transmission line from Hitchland to mid-point of TUCO to Woodward 345 kV line. Includes substation work at Hitchland and Border.	\$9,053,827
Add -50/+100MVAR SVC at Hitchland 230kV substation	\$980,565
Add 230/115/13.2kV Transformer Ckt2 at Hitchland 230kV substation	\$883,512
TOTAL	\$10,917,904

If higher queued interconnection customers withdraw from the queue, suspend or terminate their GIA, restudies will have to be conducted to determine the Interconnection Customers' allocation of shared network upgrades. All studies have been conducted on the basis of higher queued interconnection requests and the upgrades associated with those higher queued interconnection requests being placed in service.

Additional Required Network Upgrades

Certain Network Upgrades that are not the cost responsibility of the Customer are required for Interconnection. These Network Upgrades include:

1. Hitchland – Woodward 345kV double circuit transmission line,
2. Tuco – Woodward 345kV transmission line,
3. Medicine Lodge – Woodward 345kV double circuit transmission line, and
4. Medicine Lodge – Wichita double circuit 345kV transmission line.

These network upgrades are not schedule to be in service until December 31, 2014. Depending upon the status of higher or equally queued customers, the Interconnection Customer's in service date may be delayed until the in service date of these Network Upgrades.



**Facilities Study For
Southwest Power Pool (SPP)**
73.8 MW Wind-Generated Energy Facility
Hutchinson County, Texas
SPP #GEN-2010-007

November 1, 2010

Xcel Energy Services, Inc.
Transmission Planning

<Omitted text> in 2010 requested the interconnection of a wind energy facility located in Hutchinson County, Texas to the Southwestern Public Service Company (SPS), transmission network. SPS is a New Mexico Corporation and wholly owned subsidiary of Xcel Energy Inc. This facility has a net capacity of 73.8 MW. The Interconnection Customer's facility will connect to a new SPS switching station located the 115 kV line between Pringle Interchange and Riverview Interchange approximately four (4) miles northeast of Stinnett, Texas. The Interconnection Customer's expected commercial operation date and the requested back-feed date is June 30, 2012 and March 15, 2012, respectively.

The Southwest Power Pool (SPP) evaluated the request to interconnect the wind farm facility to the SPS transmission system in a System Impact Study (SIS) GEN-2010-007 completed in July 2010. The interconnection request was studied using forty-one (41) Vestas V100 wind turbines rated at 1.8 MW each for a total output of 73.8 MW at their substation, which will have one (1) 48/64/80 MVA 115/34.5 kV transformers. The Interconnection Customer is required to build 115 kV transmission line from their substation wind farm facility to the SPS new 115 kV switching station. The Interconnection Customer is required to provide capacitor banks to provide 23 MVAR of reactance at the point of interconnection and to maintain a Power Factor of 0.95 lagging and 0.95 leading at the Point of Interconnection (POI), based on SPP's SIS for Cluster Group 2, See table on page 15.

SPS requires that all construction for this request be in compliance with the latest revision of the Xcel Energy Interconnection Guidelines for Transmission Interconnection Producer-Owned Generation Greater than 20 MW, available at:

(http://www.xcelenergy.com/Texas/Company/Transmission/Pages/Transmission_Services_Interconnection_Guidelines.aspx). This document describes the requirements for connecting new generation to the Xcel Energy transmission systems including technical, protection, commissioning, operation, and maintenance. SPS will also require that the Interconnection Customer be in compliance with all applicable criteria, guidelines, standards, requirements, regulations, and procedures issued by the North American Electric Reliability Corporation (NERC), Southwest Power Pool (SPP), and the Federal Energy Regulatory Commission (FERC) or their successor organizations.

The Interconnection Customer is responsible for the cost of the Interconnection Facilities, installation of any necessary cap banks and any Direct Assigned Interconnection Facilities; inclusive of all construction required for the 115 kV transmission line from the Interconnection Customer's substation to the new SPS switching station.

As for this request (GEN-2010-007), it is anticipated that the entire process of adding the new 115 kV switching station for the acceptance of the wind farm facility output, will require approximately 24 months to complete after an Interconnection Agreement is signed and an authorization to proceed is received.

The cost of these upgrades, inclusive of the Interconnection Customer's cost for the interconnection of this wind farm facility, is shown below in Table 1, with the detailed description of the cost shown in Table 3.

Table 1, Cost Summary¹

	Interchange
Network Upgrades:	\$2,631,017
Interconnection Facilities ² :	\$ 236,346
Total:	\$2,867,363

¹ The cost estimates are 2010 dollars with an accuracy level of $\pm 20\%$.

² This is a direct assigned cost to the Interconnection Customer.

1. **Construction of New Switching Station:** See Appendix A, **Figure A- 1** for general vicinity location map.
 - 1.1. **Location:** SPS will construct a new 115 kV three (3) breaker ring bus at a new switching station. Appendix A, Figure A-2, shows a preliminary one-line of the new switching station, while, Figure A-3, shows typical elevation view of the Point of Interconnection (POI).
 - 1.2. **Bus Design:** The new 115 kV three-breaker ring-bus switching station will be built to accommodate the output from the wind energy facility.
 - 1.3. **Line Terminals:** The 115kV lines and static wire terminals will be designed to accommodate 2,000 pounds per phase conductor at maximum tension, with a maximum 15-degree pull off from normal.
 - 1.4. **Control House:** The control house for the proposed switching station will be utilized to house the new metering, protective relaying and control devices, terminal cabinets, and any fiber-optic cable terminations, etc. for the new 115kV line breaker terminals.
 - 1.5. **Security Fence:** The switching station will have a 7-foot chain-link fence with steel posts set in concrete with 1-foot of barbed wire on the top in a “V” configuration. the enclosed area will be approximately 400’ x 400’, with a rock yard surface.
 - 1.6. **Ground Grid:** A complete round grid will be installed per ANSI/IEEE STD 80-1986, with our standard 4/0 copper ground mesh on 40-foot centers with ground rods and 20-foot centers in corners and loop outside of fence.
 - 1.7. **Site Grading:** Company contractor, per company specifications, will perform any site grading and erosion control of the new switching station. Soil compaction shall be not less than 95% of laboratory density as determined by ASTM-D-698.
 - 1.8. **Station Power:** A 66 kV/120-240 volt transformer tapped off of the 115 kV bus will provide station power. A backup station power source will be taken from local distribution if it is available or a generator will be installed if none is available. A flip-flop to automatically transfer the station power will be installed.
 - 1.9. **Relay and Protection Scheme:** The new 115 kV three (3) breaker ring-bus line terminals primary protection to the interconnection customer 115 kV transmission line will use line current differential relaying over optical fiber installed in the static of the customer’s 115 kV transmission line. Secondary relaying will use mirrored bit, Permissive Overreaching Transfer Trip (POTT) over the optical fiber. An SEL 311L and an SEL 421 will be used as primary and secondary relays, respectively. No automatic re-closing scheme will be used. The SEL 421 will be used for line/bus SCADA closing conditions for the 115 kV breaker. Also, a SEL 501-0 will be used for breaker failure.

³ All modifications to SPS facilities will be owned, maintained and operated by SPS.

An SEL DTA-2 will display the bus voltage, GCB amps, MW, MVAR, and fault location. An SEL 2020 will be installed for relay communications and other functions as required.

- 1.10. **Revenue Metering:** On the SPS new switching station 115 kV line terminal to the Interconnection Customer's substation, an individual billing meter will be installed along with a meter per ANSI C12.1 accuracy class 0.2 (3-PT's IEEE C57.13 accuracy class 0.3 and 3 CT's IEEE C57.13 accuracy class 0.15) for full 3 phase 4-wire metering. Also installed for the metering units will be 3-PT's and 3-CT's for full 3-phase 4-wire metering. There will be two meters per line terminal: one will be primary and the other will be back up, each will have full 4 quadrant metering. Pulses out of the primary billing meter will be sent via SCADA to the Transmission Owner's Control Center in Amarillo, Texas.
- 1.11. **Disturbance Monitoring Device:** Disturbance-monitoring equipment (DFR), capable of recording faults, swings, and long term trending, will be installed to monitor and record conditions in the substation and on the transmission lines. The disturbance equipment shall also be equipped with a GPS time synch clock. This equipment will have communication capability with a dedicated communication circuit. The disturbance equipment will have its own dedicated dial-up communications telephone circuit.
- 1.12. **Remote Terminal Unit (RTU):** A new RTU will be utilized with communications for the new switching station. AN SEL 2020 will be installed for relay communications and other functions as required. SPS will provide and install an RTU for metering and telemetry at the Interconnection Customer's facility as required by the latest Xcel Energy Interconnection Guidelines. The direct cost will be charged to the Interconnection Customer.
- 1.13. **Communications:** To meet its Communications obligations under Article 8 of this GIA, the Interconnection Customer shall be responsible for making arrangements with the local phone company to provide telephone circuits as required by the Transmission Owner. Transmission Owner equipment may include, but is not limited to, the following: relay communication equipment, RTU, and disturbance monitoring equipment at the new Switching Station. Prior to any construction, the Interconnection Customer is required to contact the Transmission Owner substation-engineering department for all communication details.

Pursuant to Article 8.1 of this GIA, the Interconnection Customer shall provide the dedicated data circuit(s) necessary to provide Interconnection Customer data to Transmission Owner as set forth in Appendix D of this GIA. The Interconnection Customer and Transmission Owner shall cooperate reasonably to ensure that all Parties comply with the terms, recommendations, and standards in Appendix D of this GIA. The following communications schematic diagram, which includes communication equipment information for the Interconnection Customer, Transmission Provider (Southwest Power Pool) and Transmission Owner (Southwestern Public Service) is provided to assist the Parties in meeting the standards set forth in Appendix D of the GIA.

A schematic outlining the proposed communications is provided below:

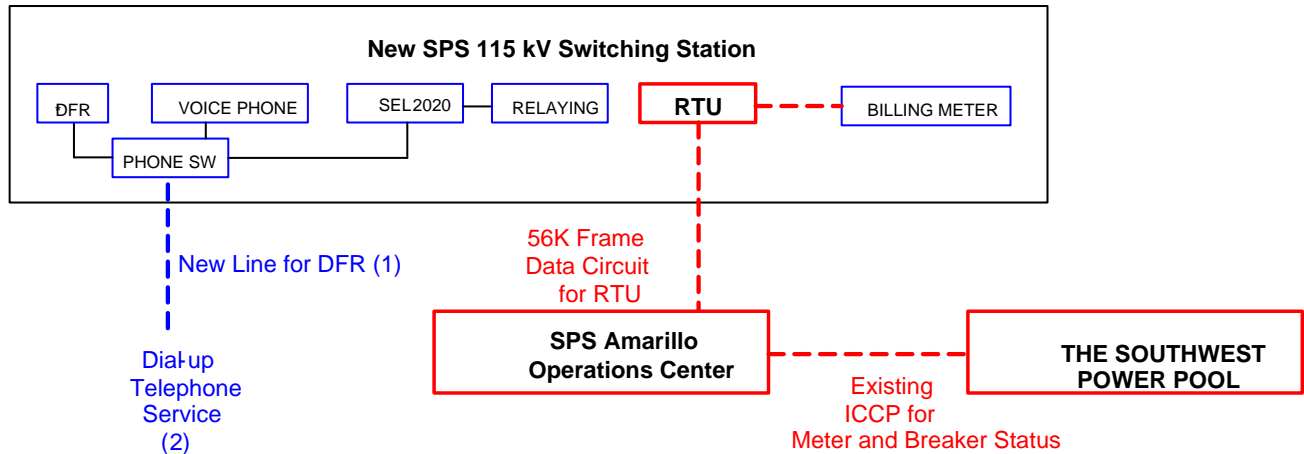

The Interconnection Customer shall be responsible for providing fiber optic communication circuit installed in their overhead transmission line static wire for protective relaying from the customer substation to the existing Pringle Interchange indicated in Section 1.9.

2. Transmission Work:

- 2.1. The Interconnection Customer will construct, own, operate, and maintain any customer owned 115 kV transmission line from the Interconnection Customer's substation to the Interconnection Point at the new SPS switching station located approximately 8 miles south of Pringle Interchange as shown in Appendix A, Figure A- 1. ***The SPS transmission design group prior to any construction by the Interconnection Customer or its contractor on any customer 115 kV transmission lines, or doing work in close proximity to any SPS transmission line, will require an engineering review of the customer's design. It is the Interconnection Customer's responsibility to initiate the design review in a timely manner before construction of any transmission line begins. If the review has not been made or the design at any of the aforementioned locations is deemed inadequate, the crossing(s) and or termination into the SPS Pringle Interchange will be delayed until the matters are resolved. SPS will not be held responsible for these delays.***

3. Right-Of-Way and Permits:

- 3.1. **Permitting:** Permitting for the construction of a new 115 kV line switching station south of Pringle Interchange is not required from the Public Utility Commission in the State of Texas. The interconnection customer will be responsible for any permitting and right of way of their substation and the 115 kV transmission line from their substation to the new SPS switching station located approximately 8 miles south of Pringle Interchange.

4. **Construction Power and Distribution Service:** It is the sole responsibility of the Interconnection Customer to make arrangements for both construction and station power, which may be required for the Interconnection Customer's wind farm facility. **Additionally, if the Interconnection Customer's substation(s) and/or construction site(s) are located outside of the SPS service area, SPS cannot provide station power (retail distribution service) and the Interconnection Customer needs to make arrangements for distribution service from the local retail provider.**

5. Project and Operating Concerns:

- 5.1. Close work between the Transmission group, the Interconnection Customer’s personnel and local operating groups will be imperative in order to meet any in-service date that has been established.
- 5.2. It is understood that any necessary capacitor banks will be installed at the Interconnection Customer’s 34.5 bus side to avoid voltage spikes on the 115 kV that adversely affects the Xcel Energy transmission system. The Interconnection customer will be required to switch the 23 MVAR capacitor bank in stages of 20 MVAR or less. This is required to maintain acceptable dynamic voltage rise as per latest revision of the Xcel Energy Interconnection Guidelines for Transmission Interconnection Producer-Owned Generation Greater than 20 MW,
(http://www.xcelenergy.com/Texas/Company/Transmission/Pages/Transmission_Services_Interconnection_Guidelines.aspx).

6. **Fault Current Study:** The available fault current at the interconnection location, without any contribution from the wind farm facilities, is shown in Table 2 below.

Table 2, - Available fault current at Point of Interconnection Location

Short Circuit Current Availability at a New SPS Switching Station located approximately 8 miles south of Pringle Interchange without contribution from Wind Farm Facility (GEN 2010-007)				
Fault Location	Fault Current (Amps)		Impedance (Ω)	
	Line-to-Ground	3-Phase	Z^+	Z^0
115 kV Bus	6,019	8,226	1.782 +j7.872	4.34 +j16.405

Estimated Construction Costs

The projects required for the interconnection of this 73.8 MW Wind Farm facility consist of the projects summarized in the table below.

Table 3, Required Interconnection Projects

Project	Description	Estimated Cost⁴
	Network Upgrades	
1	Disturbance Monitoring Device	\$ 75,000
2	Transmission Line Work	\$ 266,453
3	Build 115 kV 3-ring bus.	\$2,261,444
4	Right of Way	\$ 28,120
	Subtotal:	\$2,631,017
	Transmission Owner Interconnection Facilities (at the Interconnection Customer's expense)	
5	Communications ⁵	\$ See footnote
6	Remote Terminal Unit (RTU)	\$ 51,346
7	Revenue metering	\$ 165,000
8	115 kV Line arrestors	\$ 20,000
	Subtotal:	\$ 236,346
	Total Cost:	\$2,867,363

Engineering and Construction:

An engineering and construction schedule for the installation of the 3-115 kV breakers in a ring bus configuration is depicted below and is estimated at approximately 24 months. Other factors associated with clearances, equipment delays and work schedules could cause additional delays. The estimated time (24 months) is applicable after all required agreements are signed and internal approvals are granted.

All additional cost for work not identified in this study is the sole responsibility of the Interconnection Customer unless other arrangements are made.

⁴ The cost estimates are 2010 dollars with an accuracy level of $\pm 20\%$.

⁵ It is the Requester's responsibility to provide both the data circuit and both dial-up telephone circuits, see Section 1.13.



Figure A- 1 Approximate location of proposed Wind Farm Facility and Interconnection Customer 115 KV Transmission Line⁶

⁶ 115 kV customer transmission line shown does not represent actual route.

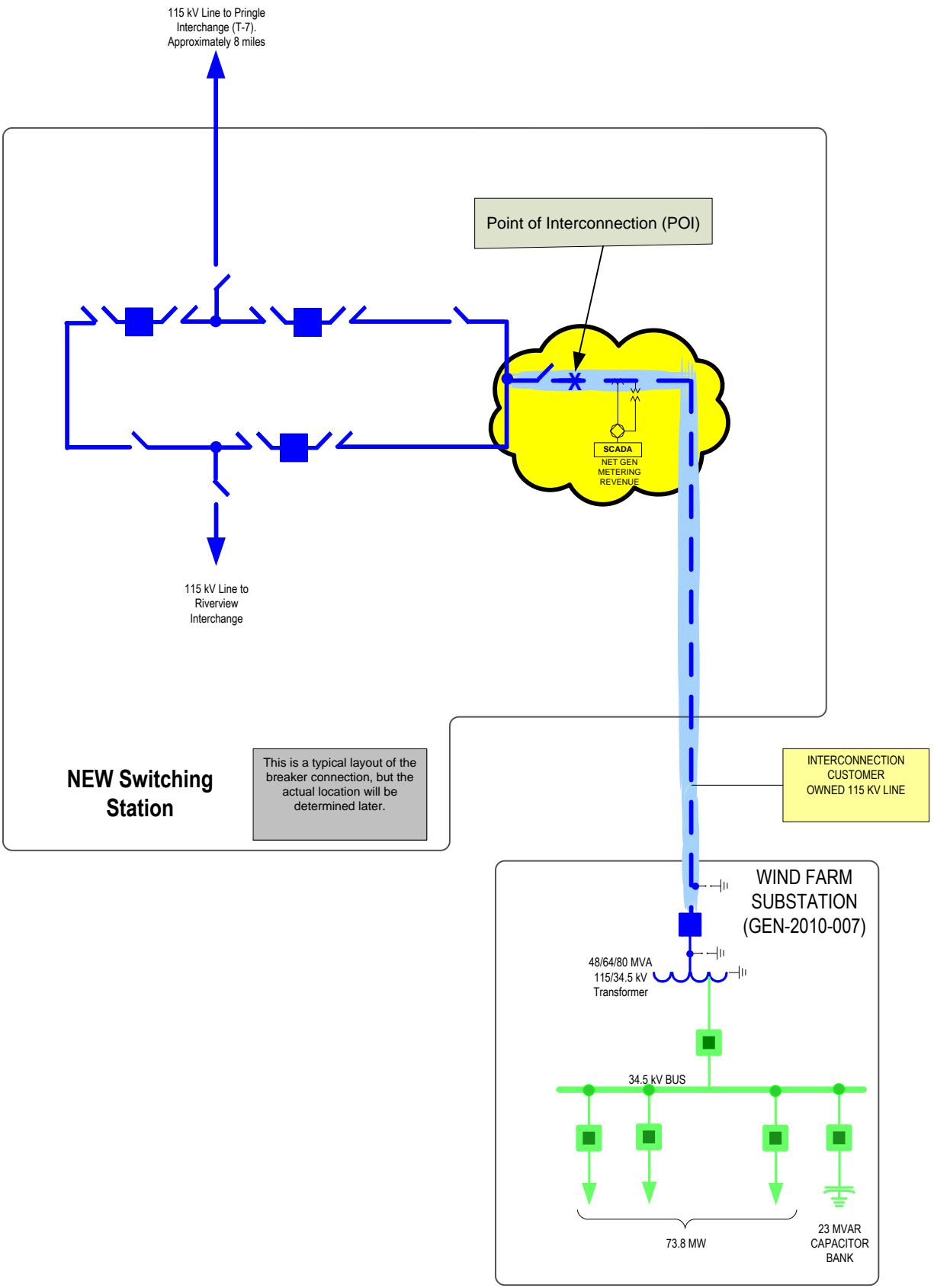

Figure A- 2 One-line Diagram of Pringle Interchange

**CUSTOMER SHALL PROVIDE
ALL MATERIAL FOR DEAD
ENDING PHASES AND STATIC
TO 115 kV DEAD END TOWER.
DEMONSTRATION PURPOSES.**

Customer's Responsibility

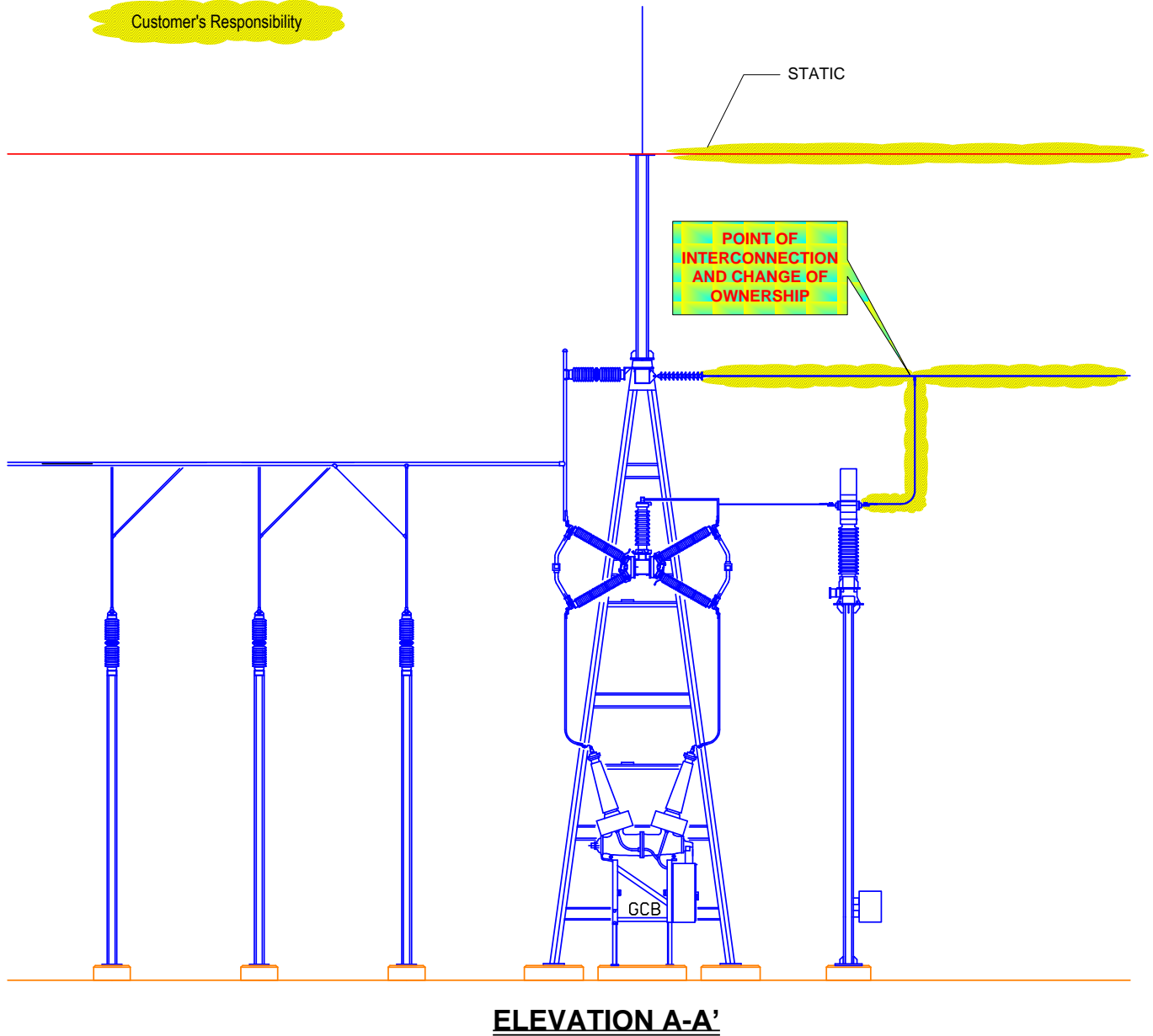

Figure A-3 Point of Interconnection & Change of Ownership (Typical)

– END OF REPORT –