



GEN-2009-008
Impact Restudy #2

***SPP Generation
Interconnection Studies***

GEN-2009-008

February 2013

Executive Summary

This document reports on the findings of a restudy for the GEN-2009-008 interconnection request. The interconnection customer has requested this restudy to determine the effects of changing wind turbine generators from the previously studied GE 1.6MW wind turbine generators to the GE1.7MW wind turbine generators.

The GEN-2009-008 interconnection request was first studied as part of the DISIS-2010-001 Definitive Impact Study, Cluster Group 11 which was posted in July 2010.

In this restudy the project uses one hundred seventeen (117) GE 1.7MW wind turbine generators for an aggregate power of 198.9MW and is located in Ness County, Kansas. The project has one 34.5/230kV substation transformer that will connect the Customer's 230kV transmission line to the Point of Interconnection (POI), the South Hays 230kV Substation.

The restudy showed that no stability problems were found during the summer or the winter peak conditions as a result of changing to the GE 1.7MW wind turbine generators. Additionally, the project wind farm was found to stay connected during the contingencies that were studied and, therefore, will meet the Low Voltage Ride Through (LVRT) requirements of FERC Order #661A.

A power factor analysis was not performed in this study. The power factor analysis results from the DISIS-2010-001 study are still valid, and the facility will be required to maintain a 95% lagging (providing VARs) and 95% leading (absorbing VARs) power factor at the point of interconnection.

With the assumptions outlined in this report and with all the required network upgrades from the GEN-2009-008 GIA in place, GEN-2009-008 should be able to reliably interconnect to the SPP transmission grid.

Nothing in this study should be construed as a guarantee of transmission service. If the customer wishes to sell power from the facility, a separate request for transmission service shall be requested on Southwest Power Pool's OASIS by the Customer.

1.0 Introduction

The interconnection customer has requested this restudy to determine the effects of changing wind turbine generators from the previously studied GE 1.6MW wind turbine generators to the GE1.7MW wind turbine generators.

The GEN-2009-008 interconnection request was first studied as part of the DISIS-2010-001 Definitive Impact Study, Cluster Group 11 which was posted in July 2010.

In this study SPP monitored the generators and transmission lines in Areas 520, 524, 525, 526, 531, 534, 536,539, 544, 640, 645, and 650.

2.0 Purpose

The purpose of this impact restudy is to evaluate the effects of using GE 1.7MW wind turbine generators on the reliability of the Transmission System.

3.0 Facilities

3.1 Customer Facility

With the GE 1.7MW wind turbine generators, the project has a maximum power output of 198.9MW and is to be located in Ness County, Kansas. The project has one 34.5/230kV substation transformer that will connect the Customer's 230kV transmission line to the Point of Interconnection (POI), the South Hays 230kV Substation. The substation transformer will be fed by a collector subsystem that contains one hundred seventeen (117) GE 1.7MW wind turbine generators.

3.2 Interconnection Facility

Figure 1 shows the interconnection facility for GEN-2009-008.

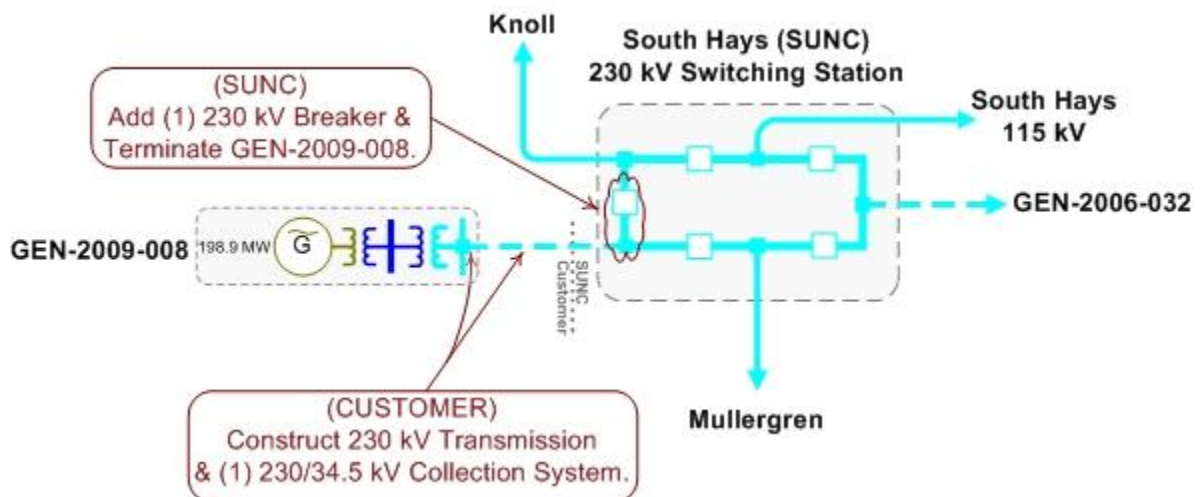

Figure 1: GEN-2009-008 POI One-line Diagram

4.0 Stability Study Criteria

FERC Order 661A Low Voltage Ride-Through Provisions (LVRT), which went into effect January 1, 2006, requires that wind generating plants remain in-service during 3-phase faults at the point of interconnection. This order may require a Static VAR Compensator (SVC) or STATCOM device be specified at the Customer facility to keep the wind generator on-line for the fault. Dynamic Stability studies performed as part of the System Impact Study will provide additional guidance as to whether the reactive compensation can be static or a portion must be dynamic (such as a SVC or STATCOM).

5.0 Model Development

Siemens PSS/E Version 32.1 was the software tool used to perform the impact restudy. For simulation purposes, the Customer's facility was simplified by using the equivalent model of the wind farm as shown in Figure 2. The data used to develop the equivalent wind farm model were supplied by the Customer.

The Customer also supplied the PSS/E Version 32.1 stability models for the GE 1.7MW wind turbine generators. The GE's reactive power capability is +0.90 to -0.90 PF.

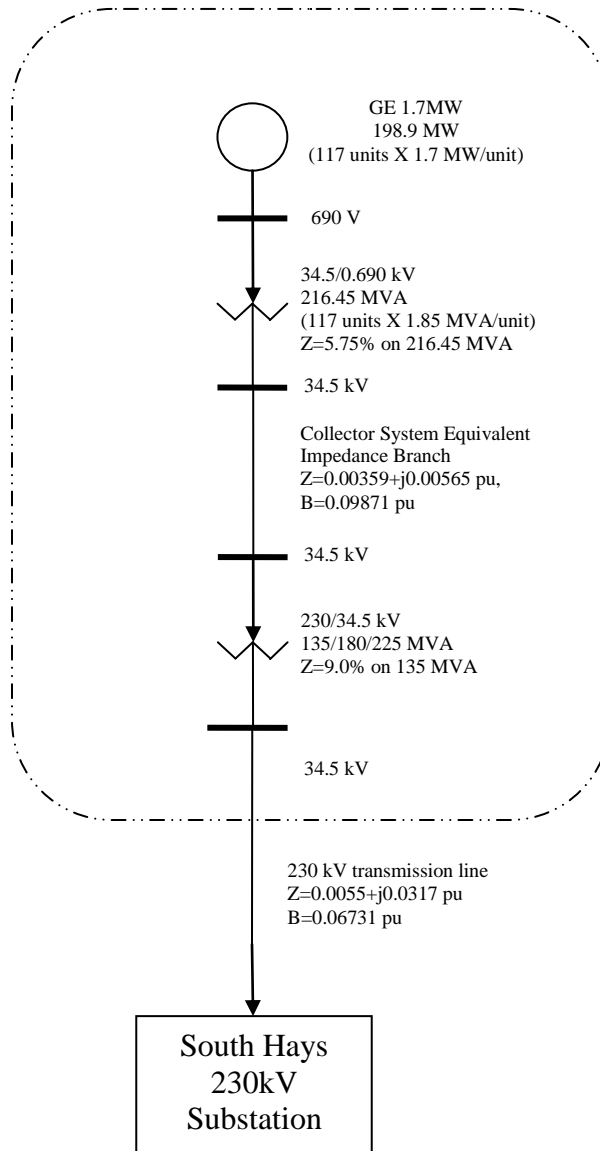

Figure 2: GEN-2009-008 Facility One-line Diagram

Prior queued requests were included in the saved cases. The prior queued requests are shown in Table 1.

Request	Size (MW)	PSS/E Model	Point of Interconnection
GEN-2001-039M	99	Vestas V90VCRS 3.0MW	Central Plains 115kV (531485)
GEN-2003-006A	201	Vestas V90VCRS	Elm Creek 230kV (539639)
GEN-2003-019	249.3	GE 1.5MW & Vestas 3.0MW	Smoky Hills 230kV (530592)
GEN-2006-031	75	Gas	Knoll 115kV (530561)
GEN-2006-032	200	Gamesa 2.0MW	South Hays 230kV (530582)
GEN-2006-040	108	Acciona AW1500 1.5MW	Mingo 115kV (531429)
GEN-2007-011	135	Acciona AW1500 1.5MW	Syracuse 115kV (531437)
GEN-2008-017	300	GE 1.5MW	Setab 345kV (531465)
GEN-2008-025	101.2	Siemens SMK203 2.3MW	Ruleton 115kV (531357)
GEN-2008-092	201	GE 1.5MW	Knoll 230kV (530558)
GEN-2009-020	48.3	Siemens 2.3MW	Tap on the Balzine to Nekoma 69kV line (560306)
GEN-2010-048	70	Nordex 2.5MW	Tap on the Ross Beach to Redline 115kV line (560366)

Table 1: Prior Queued Request Table

6.0 Stability Study Analysis

Forty-eight (48) contingencies were considered for the transient stability simulations in this scenario. These contingencies included three phase faults and single phase line faults at locations defined by SPP. Single-phase line faults were simulated by applying a fault impedance to the positive sequence network at the fault location to represent the effect of the negative and zero sequence networks on the positive sequence network. The fault impedance was computed to give a positive sequence voltage at the specified fault location of approximately 60% of pre-fault voltage. This method is in agreement with SPP current practice. The faults that were defined and simulated are listed in Table 2 below. The faults were simulated on both the summer peak and the winter peak models.

Cont. No.	Cont. Name	Description
1	FLT_01_SHAYS6_POSTROCK6_230kV_3PH	3 phase fault on South Hays 230kV Bus 530582 to Post Rock 230KV Bus 530584 CKT 1, near South Hays. a. Apply fault at the South Hays 230kV bus. b. Clear fault after 5 cycles by tripping the faulted line. c. Wait 20 cycles, and then re-close the line in (b) back into the fault. d. Leave fault on for 5 cycles, then trip the line in (b) and remove fault.
2	FLT_02_SHAYS6_POSTROCK6_230kV_1PH	<i>Single phase fault and sequence like previous</i>
3	FLT_03_SHAYS6_GREATBEND6_230kV_3PH	3 phase fault on the South Hays 230kV Bus 530582 to Great Bend 230KV Bus 539679 CKT 1, near South Hays. a. Apply fault at the South Hays 230kV. b. Clear fault after 5 cycles by tripping the faulted line. c. Wait 20 cycles, and then re-close the line in (b) back into the fault. d. Leave fault on for 5 cycles, then trip the line in (b) and remove fault.
4	FLT_04_SHAYS6_GREATBEND6_230kV_1PH	<i>Single phase fault and sequence like previous</i>
5	FLT_05_POSTROCK6_KNOLL6_230kV_3PH	3 phase fault on the Post Rock 230kV Bus 530584 to Knoll 230kV Bus 530558 CKT 1, near Post Rock. a. Apply fault at the Post Rock 230kV bus. b. Clear fault after 5 cycles by tripping the faulted line. c. Wait 20 cycles, and then re-close the line in (b) back into the fault. d. Leave fault on for 5 cycles, then trip the line in (b) and remove fault.
6	FLT_06_POSTROCK6_KNOLL6_230kV_1PH	<i>Single phase fault and sequence like previous</i>
7	FLT_07_GREATBEND6_HEIZER6_230kV_3PH	3 phase fault on the Great Bend 230kV Bus 539679 to Heizer 230kV Bus 530680 CKT 1, near Great Bend. a. Apply fault at the Great Bend 230kV bus. b. Clear fault after 5 cycles by tripping the faulted line. c. Wait 20 cycles, and then re-close the line in (b) back into the fault. d. Leave fault on for 5 cycles, then trip the line in (b) and remove fault.
8	FLT_08_GREATBEND6_HEIZER6_230kV_1PH	<i>Single phase fault and sequence like previous</i>
9	FLT_09_GREATBEND6_CIRCLE6_230kV_3PH	3 phase fault on the Great Bend 230kV Bus 539679 to Circle 230kV Bus 532871 CKT 1, near Great Bend. a. Apply fault at the Great Bend 230kV bus. b. Clear fault after 5 cycles by tripping the faulted line. c. Wait 20 cycles, and then re-close the line in (b) back into the fault. d. Leave fault on for 5 cycles, then trip the line in (b) and remove fault.
10	FLT_10_GREATBEND6_CIRCLE6_230kV_1PH	<i>Single phase fault and sequence like previous</i>

Cont. No.	Cont. Name	Description
11	FLT_11_GREATBEND6_SPEARVILLE6_230kV_3PH	3 phase fault on the Great Bend 230kV Bus 539679 to Spearville 230kV Bus 539695 CKT 1, near Great Bend. a. Apply fault at the Great Bend 230V bus. b. Clear fault after 5 cycles by tripping the faulted line. c. Wait 20 cycles, and then re-close the line in (b) back into the fault. d. Leave fault on for 5 cycles, then trip the line in (b) and remove fault.
12	FLT_12_GREATBEND6_SPEARVILLE6_230kV_1PH	<i>Single phase fault and sequence like previous</i>
13	FLT_13_POSTROCK7_SPEARVILLE7_345kV_3PH	3 phase fault on the Post Rock 345KV Bus 530583 to Spearville 345KV Bus 531469 CKT 1, near Post Rock. a. Apply fault at the Post Rock 345KV bus. b. Clear fault after 5 cycles by tripping the faulted line. c. Wait 20 cycles, and then re-close the line in (b) back into the fault. d. Leave fault on for 5 cycles, then trip the line in (b) and remove fault.
14	FLT_14_POSTROCK7_G11017POI_345kV_1PH	<i>Single phase fault and sequence like previous</i>
15	FLT_15_POSTROCK7_AXTELL_345kV_3PH	3 phase fault on the Post Rock 345KV Bus 530583 to Axtell 345kV Bus 64005 CKT 1, near Post Rock. a. Apply fault at the Post Rock 345KV bus. b. Clear fault after 5 cycles by tripping the faulted line. c. Wait 20 cycles, and then re-close the line in (b) back into the fault. d. Leave fault on for 5 cycles, then trip the line in (b) and remove fault.
16	FLT_16_POSTROCK7_AXTELL_345kV_1PH	<i>Single phase fault and sequence like previous</i>
17	FLT_17_KNOLL6_SMOKEYHILL6_230kV_3PH	3 phase fault on the Knoll 230kV Bus 530558 to Smokey Hill 230V Bus 530592 CKT 1, near Knoll. a. Apply fault at the Knoll 230kV bus. b. Clear fault after 5 cycles by tripping the faulted line. c. Wait 20 cycles, and then re-close the line in (b) back into the fault. d. Leave fault on for 5 cycles, then trip the line in (b) and remove fault.
18	FLT_18_KNOLL6_SMOKEYHILL6_230kV_1PH	<i>Single phase fault and sequence like previous</i>
19	FLT_19_KNOLL3_SALINE_115kV_3PH	3 phase fault on the Knoll 115kV Bus 530558 to Saline 115kV Bus 530551 CKT 1, near Knoll. a. Apply fault at the Knoll 115kV bus. b. Clear fault after 5 cycles by tripping the faulted line. c. Wait 20 cycles, and then re-close the line in (b) back into the fault. d. Leave fault on for 5 cycles, then trip the line in (b) and remove fault.
20	FLT_20_KNOLL3_SALINE_115kV_1PH	<i>Single phase fault and sequence like previous</i>

Cont. No.	Cont. Name	Description
21	FLT_21_KNOLL3_NHAYS3_115kV_3PH	3 phase fault on the Knoll 115kV Bus 530558 to North Hays 115kV Bus 530581 CKT 1, near Knoll. a. Apply fault at the Knoll 115kV bus. b. Clear fault after 5 cycles by tripping the faulted line. c. Wait 20 cycles, and then re-close the line in (b) back into the fault. d. Leave fault on for 5 cycles, then trip the line in (b) and remove fault.
22	FLT_22_KNOLL3_NHAYS3_115kV_1PH	<i>Single phase fault and sequence like previous</i>
23	FLT_23_KNOLL3_REDLINE_115kV_3PH	3 phase fault on the Knoll 115kV Bus 530558 to Redline 115kV Bus 530605 CKT 1, near Knoll. a. Apply fault at the Knoll 115kV bus. b. Clear fault after 5 cycles by tripping the faulted line. c. Wait 20 cycles, and then re-close the line in (b) back into the fault. d. Leave fault on for 5 cycles, then trip the line in (b) and remove fault.
24	FLT_24_KNOLL3_REDLINE_115kV_1PH	<i>Single phase fault and sequence like previous</i>
25	FLT_25_G09020TAP2_NEKOMA2_69kV_3PH	3 phase fault on the GEN-2009-020 TAP 69kV Bus 560306 to Nekoma 69kV Bus 530564 CKT 1, near GEN-2009-020 TAP. a. Apply fault at the GEN-2009-020 TAP 69kV bus. b. Clear fault after 5 cycles by tripping the faulted line. c. Wait 20 cycles, and then re-close the line in (b) back into the fault. d. Leave fault on for 5 cycles, then trip the line in (b) and remove fault.
26	FLT_26_G09020TAP2_NEKOMA2_69kV_1PH	<i>Single phase fault and sequence like previous</i>
27	FLT_27_G09020TAP2_BAZINE2_69kV_3PH	3 phase fault on the GEN-2009-020 TAP 69kV Bus 560306 to Bazine 69kV Bus 530585 CKT 1, near GEN-2009-020 TAP. a. Apply fault at the GEN-2009-020 TAP 69kV bus. b. Clear fault after 5 cycles by tripping the faulted line. c. Wait 20 cycles, and then re-close the line in (b) back into the fault. d. Leave fault on for 5 cycles, then trip the line in (b) and remove fault.
28	FLT_28_G09020TAP2_BAZINE2_69kV_1PH	<i>Single phase fault and sequence like previous</i>
29	FLT_29_SEWARD2_HUDSON2_69kV_3PH	3 phase fault on the Seward 69kV Bus 530565 to Hudson 69kV Bus 530576 CKT 1, near Seward. a. Apply fault at the Seward 69kV bus. b. Clear fault after 5 cycles by tripping the faulted line. c. Wait 20 cycles, and then re-close the line in (b) back into the fault. d. Leave fault on for 5 cycles, then trip the line in (b) and remove fault.
30	FLT_30_SEWARD2_HUDSON2_69kV_1PH	<i>Single phase fault and sequence like previous</i>

Cont. No.	Cont. Name	Description
31	FLT_31_SEWARD2_GREATBENDS6_69kV_3PH	3 phase fault on the Seward 69kV Bus 530565 to Great Bend 69kV Bus 530569 CKT 1, near Seward. a. Apply fault at the Seward 69kV bus. b. Clear fault after 5 cycles by tripping the faulted line. c. Wait 20 cycles, and then re-close the line in (b) back into the fault. d. Leave fault on for 5 cycles, then trip the line in (b) and remove fault.
32	FLT_32_SEWARD2_GREATBENDS6_69kV_1PH	<i>Single phase fault and sequence like previous</i>
33	FLT_33_NEKOMA3_ALEXANDER3_115kV_3PH	3 phase fault on the Nekoma 115kV Bus 530588 to Alexander 115kV Bus 530606 CKT 1, near Nekoma. a. Apply fault at the Nekoma 115kV bus. b. Clear fault after 5 cycles by tripping the faulted line. c. Wait 20 cycles, and then re-close the line in (b) back into the fault. d. Leave fault on for 5 cycles, then trip the line in (b) and remove fault.
34	FLT_34_NEKOMA3_ALEXANDER3_115kV_1PH	<i>Single phase fault and sequence like previous</i>
35	FLT_35_NEKOMA3_LACROSSTAP3_115kV_3PH	3 phase fault on the Nekoma 115kV Bus 530588 to Lacross Tap 115kV Bus 530602 CKT 1, near Nekoma. a. Apply fault at the Nekoma 115kV bus. b. Clear fault after 5 cycles by tripping the faulted line. c. Wait 20 cycles, and then re-close the line in (b) back into the fault. d. Leave fault on for 5 cycles, then trip the line in (b) and remove fault.
36	FLT_36_NEKOMA3_LACROSSTAP3_115kV_1PH	<i>Single phase fault and sequence like previous</i>
37	FLT_37_NESSCITY3_RANSOM3_115kV_3PH	3 phase fault on the Ness City 115kV Bus 531456 to Ransom 115kV Bus 530607 CKT 1, near Ness City. a. Apply fault at the Ness City 115kV bus. b. Clear fault after 5 cycles by tripping the faulted line. c. Wait 20 cycles, and then re-close the line in (b) back into the fault. d. Leave fault on for 5 cycles, then trip the line in (b) and remove fault.
38	FLT_38_NESSCITY3_RANSOM3_115kV_1PH	<i>Single phase fault and sequence like previous</i>
39	FLT_39_NESSCITY3_BEELER_115kV_3PH	3 phase fault on the Ness City 115kV Bus 531456 to Beeler 115kV Bus 531359 CKT 1, near Ness City. a. Apply fault at the Ness City 115kV bus. b. Clear fault after 5 cycles by tripping the faulted line. c. Wait 20 cycles, and then re-close the line in (b) back into the fault. d. Leave fault on for 5 cycles, then trip the line in (b) and remove fault.
40	FLT_40_NESSCITY3_BEELER_115kV_1PH	<i>Single phase fault and sequence like previous</i>

Cont. No.	Cont. Name	Description
41	FLT_41_SHAYS6_SHAYS3_230_115kV_3PH	3 phase fault on the South Hays 230kV Bus 530582 to South Hays 115kV Bus 530553 to South Hays 12.47kV Bus 530632 CKT 1, near South Hays 230kV. a. Apply fault at the South Hays 230kV bus. b. Clear fault after 5 cycles by tripping the faulted transformer.
42	FLT_42_POSTROCK3_POSTROCK7_230_345kV_3PH	3 phase fault on the Post Rock 230kV Bus 530584 to Post Rock 345kV Bus 530583 to Post Rock 13.8kV Bus 530673 CKT 1, near Post Rock 230 kV. a. Apply fault at the Post Rock 230kV bus. b. Clear fault after 5 cycles by tripping the faulted transformer.
43	FLT_43_GREATBEND6_GREATBEND3_115kV_3PH	3 phase fault on the Great Bend 230kV Bus 539679 to Great Bend 115kV Bus 539678 to Great Bend 13.8kV Bus 539920 CKT 1, near Great Bend 230 kV. a. Apply fault at the Great Bend 230kV bus. b. Clear fault after 5 cycles by tripping the faulted transformer.
44	FLT_44_KNOLL6_KNOLL3_230_115kV_3PH	3 phase fault on the Knoll 230kV Bus 530558 to Knoll 115kV Bus 530561 to Knoll 11.49kV Bus 530629 CKT 1, near Knoll 230 kV. a. Apply fault at the Knoll 230kV bus. b. Clear fault after 5 cycles by tripping the faulted transformer.
45	FLT_45_NEKOMA2_NEKOMA3_69_115kV_3PH	3 phase fault on the Nekoma 69kV Bus 530564 to Nekoma 115kV Bus 530608 to Nekoma 12.5kV Bus 530630 CKT 2, near Nekoma 69 kV. a. Apply fault at the Nekoma 69kV bus. b. Clear fault after 5 cycles by tripping the faulted transformer.
46	FLT_46_HEIZER2_HEIZER3_69_115kV_3PH	3 phase fault on the Heizer 69kV Bus 530563 to Heizer 115kV Bus 530601 to Heizer 12.5kV Bus 530627 CKT 2, near Heizer 69 kV. a. Apply fault at the Heizer 69kV bus. b. Clear fault after 5 cycles by tripping the faulted transformer.
47	FLT_47_SEWARD2_SEWARD3_69_115kV_3PH	3 phase fault on the Seward 69kV Bus 530565 to Seward 115kV Bus 530679 to Seward 12.5kV Bus 530631 CKT 2, near Seward 69 kV. a. Apply fault at the Seward 69kV bus. b. Clear fault after 5 cycles by tripping the faulted transformer.
48	FLT_48_HEIZER3_HEIZER6_115_230kV_3PH	3 phase fault on the Heizer 69kV Bus 530563 to Heizer 230kV Bus 530680 to Heizer 12.5kV Bus 530626 CKT 1, near Heizer 69 kV. a. Apply fault at the Heizer 69kV bus. b. Clear fault after 5 cycles by tripping the faulted transformer.

Table 2: Contingency List

7.0 Simulation Results

All faults were run for both summer and winter cases, and no tripping occurred in this study.

Table 3 summarizes the results for all faults. Complete sets of plots for summer and winter cases are available on request.

Based on the dynamic results and with all network upgrades in service, GEN-2009-008 did not cause any stability problems and remained stable for all faults studied.

No.	Cont. Name	Description	Summer	Winter
1	FLT_01_SHAYS6_POSTROCK6_230kV_3PH	3 phase fault on South Hays 230kV Bus 530582 to Post Rock 230KV Bus 530584 CKT 1, near South Hays	Stable	Stable
2	FLT_02_SHAYS6_POSTROCK6_230kV_1PH	<i>Single phase fault and sequence like previous</i>	Stable	Stable
3	FLT_03_SHAYS6_GREATBEND6_230kV_3PH	3 phase fault on the South Hays 230kV Bus 530582 to Great Bend 230KV Bus 539679 CKT 1, near South Hays	Stable	Stable
4	FLT_04_SHAYS6_GREATBEND6_230kV_1PH	<i>Single phase fault and sequence like previous</i>	Stable	Stable
5	FLT_05_POSTROCK6_KNOLL6_230kV_3PH	3 phase fault on the Post Rock 230kV Bus 530584 to Knoll 230kV Bus 530558 CKT 1, near Post Rock	Stable	Stable
6	FLT_06_POSTROCK6_KNOLL6_230kV_1PH	<i>Single phase fault and sequence like previous</i>	Stable	Stable
7	FLT_07_GREATBEND6_HEIZER6_230kV_3PH	3 phase fault on the Great Bend 230kV Bus 539679 to Heizer 230kV Bus 530680 CKT 1, near Great Bend	Stable	Stable
8	FLT_08_GREATBEND6_HEIZER6_230kV_1PH	<i>Single phase fault and sequence like previous</i>	Stable	Stable
9	FLT_09_GREATBEND6_CIRCLE6_230kV_3PH	3 phase fault on the Great Bend 230kV Bus 539679 to Circle 230kV Bus 532871 CKT 1, near Great Bend	Stable	Stable
10	FLT_10_GREATBEND6_CIRCLE6_230kV_1PH	<i>Single phase fault and sequence like previous</i>	Stable	Stable
11	FLT_11_GREATBEND6_SPEARVILLE6_230kV_3PH	3 phase fault on the Great Bend 230kV Bus 539679 to Spearville 230kV Bus 539695 CKT 1, near Great Bend	Stable	Stable
12	FLT_12_GREATBEND6_SPEARVILLE6_230kV_1PH	<i>Single phase fault and sequence like previous</i>	Stable	Stable
13	FLT_13_POSTROCK7_SPEARVILLE7_345kV_3PH	3 phase fault on the Post Rock 345KV Bus 530583 to Spearville 345KV Bus 531469 CKT 1, near Post Rock.	Stable	Stable
14	FLT_14_POSTROCK7_G11017POI_345kV_1PH	<i>Single phase fault and sequence like previous</i>	Stable	Stable
15	FLT_15_POSTROCK7_AXTELL_345kV_3PH	3 phase fault on the Post Rock 345KV Bus 530583 to Axtell 345kV Bus 64005 CKT 1, near Post Rock.	Stable	Stable
16	FLT_16_POSTROCK7_AXTELL_345kV_1PH	<i>Single phase fault and sequence like previous</i>	Stable	Stable
17	FLT_17_KNOLL6_SMOKEYHILL6_230kV_3PH	3 phase fault on the Knoll 230kV Bus 530558 to Smokey Hill 230V Bus 530592 CKT 1, near Knoll.	Stable	Stable
18	FLT_18_KNOLL6_SMOKEYHILL6_230kV_1PH	<i>Single phase fault and sequence like previous</i>	Stable	Stable
19	FLT_19_KNOLL3_SALINE_115kV_3PH	3 phase fault on the Knoll 115kV Bus 530558 to Saline 115kV Bus 530551 CKT 1, near Knoll.	Stable	Stable
20	FLT_20_KNOLL3_SALINE_115kV_1PH	<i>Single phase fault and sequence like previous</i>	Stable	Stable
21	FLT_21_KNOLL3_NHAYS3_115kV_3PH	3 phase fault on the Knoll 115kV Bus 530558 to North Hays 115kV Bus 530581 CKT 1, near Knoll.	Stable	Stable
22	FLT_22_KNOLL3_NHAYS3_115kV_1PH	<i>Single phase fault and sequence like previous</i>	Stable	Stable
23	FLT_23_KNOLL3_REDLINE_115kV_3PH	3 phase fault on the Knoll 115kV Bus 530558 to Redline 115kV Bus 530605 CKT 1, near Knoll.	Stable	Stable
24	FLT_24_KNOLL3_REDLINE_115kV_1PH	<i>Single phase fault and sequence like previous</i>	Stable	Stable

No.	Cont. Name	Description	Summer	Winter
25	FLT_25_G09020TAP2_NEKOMA2_69kV_3PH	3 phase fault on the GEN-2009-020 TAP 69kV Bus 560306 to Nekoma 69kV Bus 530564 CKT 1, near GEN-2009-020 TAP.	Stable	Stable
26	FLT_26_G09020TAP2_NEKOMA2_69kV_1PH	<i>Single phase fault and sequence like previous</i>	Stable	Stable
27	FLT_27_G09020TAP2_BAZINE2_69kV_3PH	3 phase fault on the GEN-2009-020 TAP 69kV Bus 560306 to Bazine 69kV Bus 530585 CKT 1, near GEN-2009-020 TAP.	Stable	Stable
28	FLT_28_G09020TAP2_BAZINE2_69kV_1PH	<i>Single phase fault and sequence like previous</i>	Stable	Stable
29	FLT_29_SEWARD2_HUDSON2_69kV_3PH	3 phase fault on the Seward 69kV Bus 530565 to Hudson 69kV Bus 530576 CKT 1, near Seward.	Stable	Stable
30	FLT_30_SEWARD2_HUDSON2_69kV_1PH	<i>Single phase fault and sequence like previous</i>	Stable	Stable
31	FLT_31_SEWARD2_GREATBENDS6_69kV_3PH	3 phase fault on the Seward 69kV Bus 530565 to Great Bend 69kV Bus 530569 CKT 1, near Seward.	Stable	Stable
32	FLT_32_SEWARD2_GREATBENDS6_69kV_1PH	<i>Single phase fault and sequence like previous</i>	Stable	Stable
33	FLT_33_NEKOMA3_ALEXANDER3_115kV_3PH	3 phase fault on the Nekoma 115kV Bus 530588 to Alexander 115kV Bus 530606 CKT 1, near Nekoma.	Stable	Stable
34	FLT_34_NEKOMA3_ALEXANDER3_115kV_1PH	<i>Single phase fault and sequence like previous</i>	Stable	Stable
35	FLT_35_NEKOMA3_LACROSSTAP3_115kV_3PH	3 phase fault on the Nekoma 115kV Bus 530588 to Lacross Tap 115kV Bus 530602 CKT 1, near Nekoma.	Stable	Stable
36	FLT_36_NEKOMA3_LACROSSTAP3_115kV_1PH	<i>Single phase fault and sequence like previous</i>	Stable	Stable
37	FLT_37_NESSCITY3_RANSOM3_115kV_3PH	3 phase fault on the Ness City 115kV Bus 531456 to Ransom 115kV Bus 530607 CKT 1, near Ness City.	Stable	Stable
38	FLT_38_NESSCITY3_RANSOM3_115kV_1PH	<i>Single phase fault and sequence like previous</i>	Stable	Stable
39	FLT_39_NESSCITY3_BEELER_115kV_3PH	3 phase fault on the Ness City 115kV Bus 531456 to Beeler 115kV Bus 531359 CKT 1, near Ness City.	Stable	Stable
40	FLT_40_NESSCITY3_BEELER_115kV_1PH	<i>Single phase fault and sequence like previous</i>	Stable	Stable
41	FLT_41_SHAYS6_SHAYS3_230_115kV_3PH	3 phase fault on the South Hays 230kV Bus 530582 to South Hays 115kV Bus 530553 to South Hays 12.47kV Bus 530632 CKT 1, near South Hays 230kV.	Stable	Stable
42	FLT_42_POSTROCK3_POSTROCK7_230_345kV_3PH	3 phase fault on the Post Rock 230kV Bus 530584 to Post Rock 345kV Bus 530583 to Post Rock 13.8kV Bus 530673 CKT 1, near Post Rock 230 kV.	Stable	Stable
43	FLT_43_GREATBEND6_GREATBEND3_115kV_3PH	3 phase fault on the Great Bend 230kV Bus 539679 to Great Bend 115kV Bus 539678 to Great Bend 13.8kV Bus 539920 CKT 1, near Great Bend 230 kV.	Stable	Stable

No.	Cont. Name	Description	Summer	Winter
44	FLT_44_KNOLL6_KNOLL3_230_115kV_3PH	3 phase fault on the Knoll 230kV Bus 530558 to Knoll 115kV Bus 530561 to Knoll 11.49kV Bus 530629 CKT 1, near Knoll 230 kV.	Stable	Stable
45	FLT_45_NEKOMA2_NEKOMA3_69_115kV_3PH	3 phase fault on the Nekoma 69kV Bus 530564 to Nekoma 115kV Bus 530608 to Nekoma 12.5kV Bus 530630 CKT 2, near Nekoma 69 kV	Stable	Stable
46	FLT_46_HEIZER2_HEIZER3_69_115kV_3PH	3 phase fault on the Heizer 69kV Bus 530563 to Heizer 115kV Bus 530601 to Heizer 12.5kV Bus 530627 CKT 2, near Heizer 69 kV.	Stable	Stable
47	FLT_47_SEWARD2_SEWARD3_69_115kV_3PH	3 phase fault on the Seward 69kV Bus 530565 to Seward 115kV Bus 530679 to Seward 12.5kV Bus 530631 CKT 2, near Seward 69 kV.	Stable	Stable
48	FLT_48_HEIZER3_HEIZER6_115_230kV_3PH	3 phase fault on the Heizer 69kV Bus 530563 to Heizer 230kV Bus 530680 to Heizer 12.5kV Bus 530626 CKT 1, near Heizer 69 kV.	Stable	Stable

Table 3: Contingency Simulation Results

8.0 Power Factor Analysis

A power factor analysis was not performed in this study. The power factor analysis results from the DISIS-2010-001 study are still valid, and the facility will be required to maintain a 95% lagging (providing VARs) and 95% leading (absorbing VARs) power factor at the point of interconnection.

9.0 Conclusion

The findings of the restudy show that no stability problems were observed during the summer or the winter peak conditions due to the use of the GE 1.7MW wind turbine generators. Additionally, the project wind farm was found to stay connected during the contingencies that were studied and therefore, meet the Low Voltage Ride Through (LVRT) requirements of FERC Order #661A.

A power factor analysis was not performed in this study. The power factor analysis results from the DISIS-2010-001 study are still valid, and the facility will be required to maintain a 95% lagging (providing VARs) and 95% leading (absorbing VARs) power factor at the point of interconnection.

With the assumptions outlined in this report and with all required network upgrades from the GEN-2009-008 GIA in place, GEN-2009-008 with the wind turbine generators described in the study should be able to reliably interconnect to the SPP transmission grid.