



# Impact Study of Limited Operation for Generator Interconnection

## GEN-2008-086N02

December 2012  
Generation Interconnection



---

## Executive Summary

---

<OMITTED TEXT> (Interconnection Customer; GEN-2008-086N02) has requested a Limited Operation System Impact Study under the Southwest Power Pool Open Access Transmission Tariff (OATT) for 200.6 MW of wind generation to be interconnected as an Energy Resource (ER) into a transmission facility of the Nebraska Public Power District (NPPD) in Madison County, Nebraska. GEN-2008-086N02, under GIA Section 5.9, has requested this Limited Operation Interconnection Study (LOIS) to determine the impacts of interconnecting to the transmission system before all required Network Upgrades identified in the DISIS-2009-001 (or most recent iteration) Impact Study can be placed into service.

This LOIS addresses the effects of interconnecting the plant to the rest of the transmission system for the system topology and conditions as expected on January 1, 2014. GEN-2008-086N02 is requesting the interconnection of one-hundred eighteen (118) General Electric 1.7 MW wind turbine generators and associated facilities into a tap on the Fort Randall – Kelly (Columbus) 230kV. For the typical LOIS, both a power flow and transient stability analysis are conducted. The LOIS assumes that only the higher queued projects listed within Table 1 of this study might go into service before the completion of all Network Upgrades identified within Table 2 of this report. If additional generation projects, listed within Table 3, with queue priority equal to or higher than the study project request rights to go into commercial operation before all Network Upgrades identified within Table 2 of this report are completed, this LOIS may need to be restudied to ensure that interconnection service remains for the GEN-2008-086N02 request.

Power flow analysis from this LOIS has determined that the GEN-2008-086N02 request can interconnect a limited amount of generation as an Energy Resource prior to the completion of the required Network Upgrades, listed within Table 2 of this report. There is no more than 98 MW of Limited Operation Interconnection Service available for the period of January 1, 2014 until the completion of the Fort Randall – Kelly 230kV re-rate upgrades. The upgrades on this line are scheduled for completion in October, 2014. Should any other projects, other than those listed within Table 1 of this report, come into service an additional study may be required to determine if any limited operation service is available. It should be noted that although this LOIS analyzed many of the most probable contingencies, it is not an all-inclusive list that can account for every operational situation. Because of this, it is likely that the Customer may be required to reduce their generation output to 0MW under certain system conditions to allow system operators to maintain the reliability of the transmission network. Transient stability analysis from this LOIS has determined that the transmission system will remain stable for the twenty-five (25) selected faults for the limited operation interconnection of GEN-2008-086N02.

Nothing in this study should be construed as a guarantee of transmission service. If the customer wishes to sell power from the facility, a separate request for transmission service must be requested on Southwest Power Pool's OASIS by the Customer.

---

# Table of Contents

---

<b>Executive Summary</b> .....	<b>i</b>
<b>Table of Contents</b> .....	<b>ii</b>
<b>Purpose</b> .....	<b>1</b>
<b>Facilities</b> .....	<b>4</b>
Generating Facility .....	4
Interconnection Facilities.....	4
Base Case Network Upgrades .....	4
<b>Power Flow Analysis</b> .....	<b>5</b>
Model Preparation .....	5
Study Methodology and Criteria.....	5
Results .....	5
<b>Stability Analysis</b> .....	<b>22</b>
<b>Model Preparation</b> .....	22
<b>Disturbances</b> .....	22
<b>Power Factor Analysis</b> .....	23
<b>Results</b> .....	23
<b>FERC LVRT Compliance</b> .....	24
<b>Conclusion</b> .....	<b>25</b>

---

## Purpose

---

<OMITTED TEXT> (Interconnection Customer) has requested a Limited Operation System Impact Study (LOIS) under the Southwest Power Pool (SPP) Open Access Transmission Tariff (OATT) for an interconnection request into a transmission tie facility between the Western Area Power Administration (WAPA) and the Nebraska Public Power District (NPPD). The point of interconnection facilities will be constructed and owned by NPPD.

The purpose of this study is to evaluate the impacts of interconnecting GEN-2008-086N02 request of 200.6 MW comprised of one-hundred eighteen (118) General Electric 1.7 MW wind turbine generators and associated facilities interconnecting into a tap on the WAPA Fort Randall – NPPD Kelly (Columbus) 230kV transmission line in Madison County, Nebraska. The Customer has requested this amount to be studied as an Energy Resource (ER) with a Limited Operation Interconnection Service to commence on or around January of 2014.

Both power flow and transient stability analysis were conducted for this Limited Operation Interconnection Service. Limited Operation Studies are conducted under GIA Section 5.9.

The LOIS considers the Base Case as well as all Generating Facilities (and with respect to (b) below, any identified Network Upgrades associated with such higher queued interconnection) that, on the date the LOIS is commenced:

- a) are directly interconnected to the Transmission System;
- b) are interconnected to Affected Systems and may have an impact on the Interconnection Request;
- c) have a pending higher queued Interconnection Request to interconnect to the Transmission System listed in Table 1; or
- d) have no Queue Position but have executed an LGIA or requested that an unexecuted LGIA be filed with FERC.

Any changes to these assumptions, for example, one or more of the previously queued requests not included within this study execute an interconnection agreement and commencing commercial operation, may require a re-study of this LOIS at the expense of the Customer.

Nothing within this System Impact Study constitutes a request for transmission service or confers upon the Interconnection Customer any right to receive transmission service rights. Should the Customer require transmission service, those rights should be requested through SPP's Open Access Same-Time Information System (OASIS).

This LOIS study included prior queued generation interconnection requests. Those listed within Table 1 are the generation interconnection requests that are assumed to have rights to either full or partial interconnection service prior to the requested 1/2014 in-service of GEN-2008-086N02 for this LOIS. Also listed in Table 1 are both the amount of MWs of interconnection service expected at the effective time of this study and the total MWs requested of interconnection service, the fuel

type, the point of interconnection (POI), and the current status of each particular prior queued request.

*Table 1: Generation Requests Included within LOIS*

Project	MW	Total MW	Fuel Source	POI	Status
Fort Randle (WAPA)	352.0	352.0	Hydro	Ft. Randle 230kV	Commercial Operation
Gavins Point (WAPA)	132.0	132.0	Hydro	Gavins Point 115kV	Commercial Operation
Spirit Mound BEPC (WAPA)	105.0	105.0	Oil	Spirit Mound 115kV	Commercial Operation
Beatrice Power Station (NPPD)	250.0	250.0	Gas	Beatrice Power Station 115kV	Commercial Operation
Sheldon Station (NPPD)	225.0	225.0	Coal	Sheldon 115kV	Commercial Operation
Columbus (NPPD)	45.0	45.0	Hydro	Columbus 115kV	Commercial Operation
North Platte-Lexington (NPPD)	56.0	56.0	Hydro	John_1, John_2, & Jeffrey 115kV	Commercial Operation
Broken Bow (NPPD)	8.3	8.3	Heat	Broken Bow 115kV	Commercial Operation
Burwell (NPPD)	3.0	3.0	Heat	Ord 115kV	Commercial Operation
Ord (NPPD)	11.9	11.9	Heat	Ord 115kV	Commercial Operation
Stuart (NPPD)	2.1	2.1	Heat	Ainsworth 115kV	Commercial Operation
GEN-2002-023N	0.8	0.8	Wind	Harmony 115kV	Commercial Operation
GEN-2003-021N (Ainsworth)	60.0	75.0	Wind	Ainsworth Wind Tap 115kV	Commercial Operation
GEN-2004-023N (ADM CoGen)	75.0	75.0	Coal	Columbus 115kV	Commercial Operation
GEN-2006-020N (Crofton Hills)	42.0	42.0	Wind	Bloomfield 115kV	Commercial Operation
GEN-2006-038N05 (Broken Bow)	80.0	80.0	Wind	Broken Bow 115kV	Commercial Operation
GEN-2006-038N19 (Laredo Ridge)	80.0	80.0	Wind	Petersburg North 115kV	Commercial Operation
GEN-2006-044N (Petersburg)	40.5	40.5	Wind	Petersburg North 115kV	Commercial Operation
GEN-2007-011N08 (Elkhorn Ridge)	81.0	81.0	Wind	Bloomfield 115kV	Commercial Operation
GEN-2008-119O (Flat Water)	60.0	60.0	Wind	S1399 161kV	Commercial Operation
GEN-2008-086N02	200.6	200.6	Wind	Tap Ft. Randall – Kelly 230kV	IA Executed/On Schedule

This LOIS was required because the Customer is requesting interconnection prior to the completion of all of their required upgrades listed within the latest iteration of their Definitive Interconnection System Impact Study (DISIS). Table below lists the required upgrade projects for which this request has cost responsibility. GEN-2008-086N02 was included within the DISIS-2009-001 that was last restudied in early 2011 and posted April 4, 2011. This report can be located here at the following GI Study URL:

[http://spooasis.spp.org/documents/swpp/transmission/GenStudies.cfm?YearType=2009\\_Impact\\_Studies](http://spooasis.spp.org/documents/swpp/transmission/GenStudies.cfm?YearType=2009_Impact_Studies)

*Table 2: Upgrade Projects not included but Required for Full Interconnection Service*

Upgrade Project	Type	Description	Status
Re-Rate Ft Randall – GEN-2008-086N02 POI – Kelly (Columbus) 230kV	(2b) Network Upgrade which 100% Cost is Customer Responsibility	Raise structures and line clearance necessary to re-rate to 320MVA	Current Estimated In-Service date of 10/1/2014

Any changes to these assumptions, for example, one or more of the previously queued requests not included within this study execute an interconnection agreement and commencing commercial operation, may require a re-study of this LOIS at the expense of the Customer. The higher or equally queued projects that were not included in this study are listed in Table 3. While this list is not all inclusive it is a list of the most probable and affecting prior queued requests that were not

included within this LOIS, either because no request for an LOIS has been made or the request is on suspension, etc.

*Table 3: Higher or Equally Queued GI Requests not included within LOIS*

<b>Project</b>	<b>Total MW</b>	<b>Fuel</b>	<b>POI</b>	<b>Status</b>
GEN-2004-005N	30.0	Wind	St. Francis 115kV	IA Executed/On Suspension
GEN-2007-015	135.0	Wind	Tap S1399 – Kelly (WERE) 161kV	IA Executed/On Schedule for 12/2014
GEN-2006-037N01	75.0	Wind	Broken Bow 115kV	IA Executed/On Suspension

Nothing in this System Impact Study constitutes a request for transmission service or grants the Interconnection Customer any rights to transmission service.

# Facilities

## Generating Facility

GEN-2008-086N02 Interconnection Customer’s request to interconnect a total of 200.6 MW is comprised of one-hundred eighteen (118) General Electric 1.7 MW wind turbine generators and associated interconnection facilities.

## Interconnection Facilities

The POI for GEN-2008-086N02 Interconnection Customer is at a tap on the WAPA Fort Randall – NPPD Kelly (Columbus) 230kV transmission line in Madison County, Nebraska Figure 1 depicts the one-line diagram of the local transmission system including the POI as well as the power flow model representing the request.

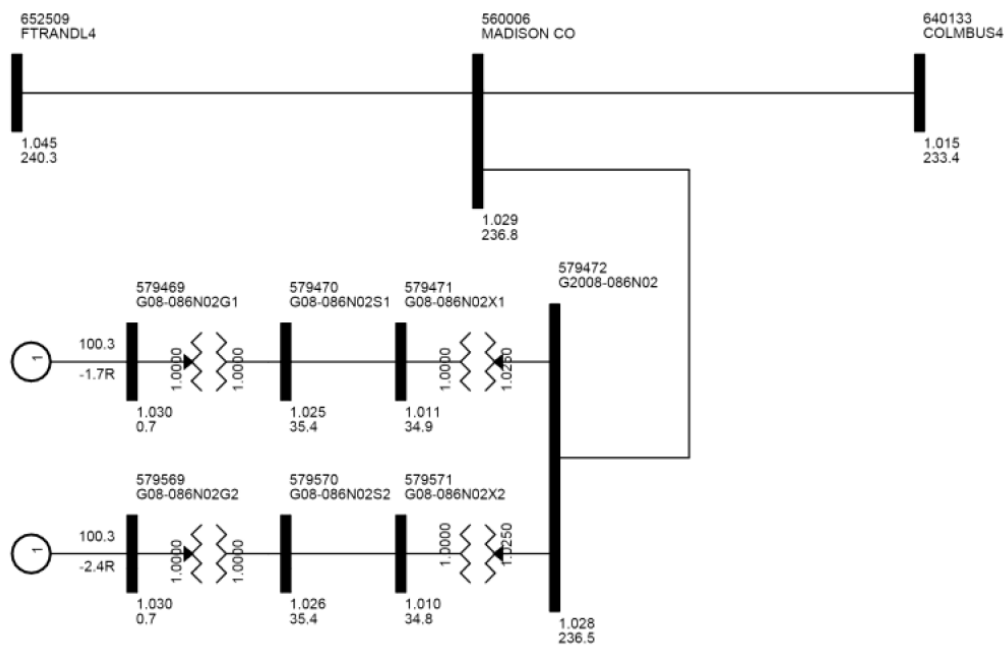

Figure 1: Proposed POI Configuration and Request Power Flow Model

## Base Case Network Upgrades

The Network Upgrades included within the cases used for this LOIS study are those facilities that are a part of the SPP Transmission Expansion Plan or the Balanced Portfolio projects that have in-service dates prior to the GEN-2008-086N02 LOIS requested in-service date of January 1, 2014. These facilities have an approved Notice to Construct (NTC), or are in construction stages and expected to be in-service at the effective time of this study. No other upgrades were included for this LOIS. If for some reason, construction on these projects is discontinued, a restudy may be needed to determine the interconnection service availability of the Customer.

---

## Power Flow Analysis

---

Power flow analysis is used to determine if the transmission system can accommodate the injection from the request without violating thermal or voltage transmission planning criteria.

### Model Preparation

Power flow analysis was performed using modified versions of the 2012 series of transmission service request study models including the 2013 (spring, summer, and winter) seasonal models. To incorporate the Interconnection Customer's request, a re-dispatch of existing generation within SPP was performed with respect to the amount of the Customer's injection and the interconnecting Balancing Authority. This method allows the request to be studied as an Energy Resource (ERIS) Interconnection Request. For this LOIS, only the previous queued requests listed in Table 1 were assumed to be in-service.

### Study Methodology and Criteria

The ACCC function of PSS/E is used to simulate contingencies, including single and multiple facility (i.e. breaker-to-breaker, etc.) outages, within all of the control areas of SPP and other control areas external to SPP and the resulting data analyzed. This satisfies the "more probable" contingency testing criteria mandated by NERC and the SPP criteria.

The contingency set includes all SPP control area branches and ties 69kV and above, first tier Non-SPP control area branches and ties 115 kV and above, any defined contingencies for these control areas, and generation unit outages for the SPP control areas with SPP reserve share program redispatch.

The monitor elements include all SPP control area branches, ties, and buses 69 kV and above, and all first tier Non-SPP control area branches and ties 69 kV and above. NERC Power Transfer Distribution Flowgates for SPP and first tier Non-SPP control area are monitored. Additional NERC Flowgates are monitored in second tier or greater Non-SPP control areas. Voltage monitoring was performed for SPP control area buses 69 kV and above.

### Results

The LOIS ACCC analysis indicates that the Customer can interconnect generation into the NPPD transmission system as requested before all required upgrades listed within the DISIS-2009-001 study can be placed into service. There is no more than 98.9 MW of Limited Operation Interconnection Service available for the period of January 1, 2014 until the completion of the Fort Randall – Kelly 230kV upgrades. Should any other projects, other than those listed within Table 1 of this report, come into service an additional study may be required to determine if any limited operation service is available.

ACCC results for the LOIS can be found in Table 4 below. The most limiting contingencies which affect the limited operation of GEN-2008-086N02 and overload the WAPA Fort Randall – Kelly (Columbus) 230kV are as follows:



Power Flow Analysis

- WAPA Fort Randall – WAPA Utica Junction 230kV
- A multi-facility outage called DAK02WAPAB2 – defined by disconnecting Bus 652526 (Utica Junction 230kV) which switches out of service three 230kV transmission lines and the 230/115/13.2kV Transformer at Utica Junction
- WAPA Fort Thompson – NPPD Grand Island 345kV
- WAPA Fort Randall – WAPA Sioux City 230KV
- NPPD Hoskins – MidAmerican Energy (MEC) Raun 345kV

As can be seen by the previous list of affecting contingencies and those listed within Table 4, the interconnection and limited operation of GEN-2008-086N02 is highly dependent on the system status of area SPP-WAPA and SPP-MEC ties, as well as others. The results listed within Table 4 shows that there will be enough interconnection availability on the transmission system to allow limited operation of no more than 98MW for the system conditions tested. It should be noted that although this LOIS analyzed many of the most probable contingencies, it is not an all-inclusive list that can account for every operational situation. Because of this, it is likely that the Customer may be required to reduce their generation output to 0MW under certain system conditions to allow system operators to maintain the reliability of the transmission network.

Power Flow Analysis

Table 4: Interconnection Constraints for Mitigation of GEN-2008-086N02 LOIS

Season	Dispatch Group	Flow	Overloaded Element	RATEA (MVA)	RATEB (MVA)	TDF	TC% LOADING	Max MW Available	Contingency
13SP	00ALL	TO->FROM	KELLY - MADISONCO 230.00 230KV CKT 1	192	192	0.777	141.2	98.9	FT RANDAL - UTICA JCT 230KV CKT 1
13SP	00G08_086N02	TO->FROM	KELLY - MADISONCO 230.00 230KV CKT 1	192	192	0.777	141.2	98.9	FT RANDAL - UTICA JCT 230KV CKT 1
13SP	00ALL	TO->FROM	KELLY - MADISONCO 230.00 230KV CKT 1	192	192	0.778	141.1	99.2	DAK02WAPAB2
13SP	00G08_086N02	TO->FROM	KELLY - MADISONCO 230.00 230KV CKT 1	192	192	0.778	141.1	99.2	DAK02WAPAB2
13SP	00ALL	TO->FROM	KELLY - MADISONCO 230.00 230KV CKT 1	192	192	0.768	138.4	104.5	FT THOMPSON - GRAND ISLAND 345KV CKT 1
13SP	00G08_086N02	TO->FROM	KELLY - MADISONCO 230.00 230KV CKT 1	192	192	0.768	138.4	104.5	FT THOMPSON - GRAND ISLAND 345KV CKT 1
13SP	00ALL	TO->FROM	KELLY - MADISONCO 230.00 230KV CKT 1	192	192	0.775	135.8	111.9	FT RANDAL - SIOUX CITY 230KV CKT 1
13SP	00G08_086N02	TO->FROM	KELLY - MADISONCO 230.00 230KV CKT 1	192	192	0.775	135.8	111.9	FT RANDAL - SIOUX CITY 230KV CKT 1
13SP	00ALL	TO->FROM	KELLY - MADISONCO 230.00 230KV CKT 1	192	192	0.757	134.2	113.9	HOSKINS - RAUN 345KV CKT 1
13SP	00G08_086N02	TO->FROM	KELLY - MADISONCO 230.00 230KV CKT 1	192	192	0.757	134.2	113.9	HOSKINS - RAUN 345KV CKT 1
13SP	00ALL	TO->FROM	KELLY - MADISONCO 230.00 230KV CKT 1	192	192	0.769	133.1	117.9	NEB001NPPB2
13SP	00ALL	TO->FROM	KELLY - MADISONCO 230.00 230KV CKT 1	192	192	0.769	133.1	117.9	LN-WAPA6
13SP	00G08_086N02	TO->FROM	KELLY - MADISONCO 230.00 230KV CKT 1	192	192	0.769	133.1	117.9	NEB001NPPB2
13SP	00G08_086N02	TO->FROM	KELLY - MADISONCO 230.00 230KV CKT 1	192	192	0.769	133.1	117.9	LN-WAPA6
13SP	00ALL	TO->FROM	KELLY - MADISONCO 230.00 230KV CKT 1	192	192	0.769	133.0	118.1	FT RANDAL - SPENCER 115KV CKT 1
13SP	00G08_086N02	TO->FROM	KELLY - MADISONCO 230.00 230KV CKT 1	192	192	0.769	133.0	118.1	FT RANDAL - SPENCER 115KV CKT 1
13SP	00ALL	TO->FROM	KELLY - MADISONCO 230.00 230KV CKT 1	192	192	0.769	132.7	119	ONEILL - SPENCER 115KV CKT 1
13SP	00G08_086N02	TO->FROM	KELLY - MADISONCO 230.00 230KV CKT 1	192	192	0.769	132.7	119	ONEILL - SPENCER 115KV CKT 1
13SP	00ALL	TO->FROM	KELLY - MADISONCO 230.00 230KV CKT 1	192	192	0.756	132.1	119.1	TRF-HOSKINS
13SP	00G08_086N02	TO->FROM	KELLY - MADISONCO 230.00 230KV CKT 1	192	192	0.756	132.1	119.1	TRF-HOSKINS
13SP	00ALL	TO->FROM	KELLY - MADISONCO 230.00 230KV CKT 1	192	192	0.768	130.9	123.4	GEN640009 1-COOPER NUCLEAR STATION
13SP	00G08_086N02	TO->FROM	KELLY - MADISONCO 230.00 230KV CKT 1	192	192	0.768	130.9	123.4	GEN640009 1-COOPER NUCLEAR STATION
13SP	00ALL	TO->FROM	KELLY - MADISONCO 230.00 230KV CKT 1	192	192	0.752	130.1	123.7	COLUMEAST - NW68TH & HOLDREGE 345KV CKT 1
13SP	00G08_086N02	TO->FROM	KELLY - MADISONCO 230.00 230KV CKT 1	192	192	0.752	130.1	123.7	COLUMEAST - NW68TH & HOLDREGE 345KV CKT 1
13SP	00ALL	TO->FROM	KELLY - MADISONCO 230.00 230KV CKT 1	192	192	0.768	130.5	124.4	GEN645012 2-NEBRASKA CITY 2
13SP	00G08_086N02	TO->FROM	KELLY - MADISONCO 230.00 230KV CKT 1	192	192	0.768	130.5	124.4	GEN645012 2-NEBRASKA CITY 2
13SP	00ALL	TO->FROM	KELLY - MADISONCO 230.00 230KV CKT 1	192	192	0.768	130.3	124.9	GEN532751 1-WOLF CREEK GENERATING STATION UNIT 1
13SP	00G08_086N02	TO->FROM	KELLY - MADISONCO 230.00 230KV CKT 1	192	192	0.768	130.3	124.9	GEN532751 1-WOLF CREEK GENERATING STATION UNIT 1
13SP	00ALL	TO->FROM	KELLY - MADISONCO 230.00 230KV CKT 1	192	192	0.768	130.2	125	GEN645011 1-NEBRASKA CITY 1
13SP	00G08_086N02	TO->FROM	KELLY - MADISONCO 230.00 230KV CKT 1	192	192	0.768	130.2	125	GEN645011 1-NEBRASKA CITY 1
13SP	00ALL	TO->FROM	KELLY - MADISONCO 230.00 230KV CKT 1	192	192	0.768	130.0	125.7	GEN640011 2-GERALD GENTLEMAN STATION UNIT 2
13SP	00G08_086N02	TO->FROM	KELLY - MADISONCO 230.00 230KV CKT 1	192	192	0.768	130.0	125.7	GEN640011 2-GERALD GENTLEMAN STATION UNIT 2
13SP	00ALL	TO->FROM	KELLY - MADISONCO 230.00 230KV CKT 1	192	192	0.768	129.7	126.3	GEN640010 1-GERALD GENTLEMAN STATION UNIT 1
13SP	00G08_086N02	TO->FROM	KELLY - MADISONCO 230.00 230KV CKT 1	192	192	0.768	129.7	126.3	GEN640010 1-GERALD GENTLEMAN STATION UNIT 1

Power Flow Analysis

Season	Dispatch Group	Flow	Overloaded Element	RATEA (MVA)	RATEB (MVA)	TDF	TC% LOADING	Max MW Available	Contingency
13SP	00ALL	TO->FROM	KELLY - MADISONCO 230.00 230KV CKT 1	192	192	0.768	129.5	126.8	GEN542962 2-IATAN UNIT #2
13SP	00G08_086N02	TO->FROM	KELLY - MADISONCO 230.00 230KV CKT 1	192	192	0.768	129.5	126.8	GEN542962 2-IATAN UNIT #2
13SP	00ALL	TO->FROM	KELLY - MADISONCO 230.00 230KV CKT 1	192	192	0.745	128.6	126.9	COLUMWEST - GRAND ISLAND 230KV CKT 1
13SP	00G08_086N02	TO->FROM	KELLY - MADISONCO 230.00 230KV CKT 1	192	192	0.745	128.6	126.9	COLUMWEST - GRAND ISLAND 230KV CKT 1
13SP	00ALL	TO->FROM	KELLY - MADISONCO 230.00 230KV CKT 1	192	192	0.770	129.3	127.6	RASMUSN - UTICA JCT 230KV CKT 1
13SP	00G08_086N02	TO->FROM	KELLY - MADISONCO 230.00 230KV CKT 1	192	192	0.770	129.3	127.6	RASMUSN - UTICA JCT 230KV CKT 1
13SP	00ALL	TO->FROM	KELLY - MADISONCO 230.00 230KV CKT 1	192	192	0.766	129.0	127.8	SIOUX CITY - TWIN CHURCH 230KV CKT 1
13SP	00G08_086N02	TO->FROM	KELLY - MADISONCO 230.00 230KV CKT 1	192	192	0.766	129.0	127.8	SIOUX CITY - TWIN CHURCH 230KV CKT 1
13SP	00ALL	TO->FROM	KELLY - MADISONCO 230.00 230KV CKT 1	192	192	0.768	129.0	128.1	GEN542957 1-IATAN UNIT #1
13SP	00G08_086N02	TO->FROM	KELLY - MADISONCO 230.00 230KV CKT 1	192	192	0.768	129.0	128.1	GEN542957 1-IATAN UNIT #1
13SP	00ALL	TO->FROM	KELLY - MADISONCO 230.00 230KV CKT 1	192	192	0.768	129.0	128.1	GEN532651 1-JEFFREY ENERGY CENTER UNIT 1
13SP	00G08_086N02	TO->FROM	KELLY - MADISONCO 230.00 230KV CKT 1	192	192	0.768	129.0	128.1	GEN532651 1-JEFFREY ENERGY CENTER UNIT 1
13SP	00ALL	TO->FROM	KELLY - MADISONCO 230.00 230KV CKT 1	192	192	0.768	129.0	128.1	NEB02WAPAB2
13SP	00G08_086N02	TO->FROM	KELLY - MADISONCO 230.00 230KV CKT 1	192	192	0.768	129.0	128.1	NEB02WAPAB2
13SP	00ALL	TO->FROM	KELLY - MADISONCO 230.00 230KV CKT 1	192	192	0.768	129.0	128.2	GEN532652 1-JEFFREY ENERGY CENTER UNIT 2
13SP	00G08_086N02	TO->FROM	KELLY - MADISONCO 230.00 230KV CKT 1	192	192	0.768	129.0	128.2	GEN532652 1-JEFFREY ENERGY CENTER UNIT 2
13SP	00ALL	TO->FROM	KELLY - MADISONCO 230.00 230KV CKT 1	192	192	0.768	129.0	128.2	GEN532653 1-JEFFREY ENERGY CENTER UNIT 3
13SP	00G08_086N02	TO->FROM	KELLY - MADISONCO 230.00 230KV CKT 1	192	192	0.768	129.0	128.2	GEN532653 1-JEFFREY ENERGY CENTER UNIT 3
13SP	00ALL	TO->FROM	KELLY - MADISONCO 230.00 230KV CKT 1	192	192	0.768	128.9	128.3	KEYSTONE - SIDNEY 345KV CKT 1
13SP	00G08_086N02	TO->FROM	KELLY - MADISONCO 230.00 230KV CKT 1	192	192	0.768	128.9	128.3	KEYSTONE - SIDNEY 345KV CKT 1
13SP	00ALL	TO->FROM	KELLY - MADISONCO 230.00 230KV CKT 1	192	192	0.768	128.8	128.6	GAVINS POINT - HARTINGTON 115KV CKT 1
13SP	00G08_086N02	TO->FROM	KELLY - MADISONCO 230.00 230KV CKT 1	192	192	0.768	128.8	128.6	GAVINS POINT - HARTINGTON 115KV CKT 1
13SP	00ALL	TO->FROM	KELLY - MADISONCO 230.00 230KV CKT 1	192	192	0.768	128.8	128.7	HANLON - STORLA 230KV CKT 1
13SP	00G08_086N02	TO->FROM	KELLY - MADISONCO 230.00 230KV CKT 1	192	192	0.768	128.8	128.7	HANLON - STORLA 230KV CKT 1
13SP	00ALL	TO->FROM	KELLY - MADISONCO 230.00 230KV CKT 1	192	192	0.768	128.7	128.7	GEN641089 2-ENERGY CENTER 2
13SP	00G08_086N02	TO->FROM	KELLY - MADISONCO 230.00 230KV CKT 1	192	192	0.768	128.7	128.7	GEN641089 2-ENERGY CENTER 2
13SP	00ALL	TO->FROM	KELLY - MADISONCO 230.00 230KV CKT 1	192	192	0.768	128.7	128.8	GEN640028 1-COLUMCOGENERATION
13SP	00G08_086N02	TO->FROM	KELLY - MADISONCO 230.00 230KV CKT 1	192	192	0.768	128.7	128.8	GEN640028 1-COLUMCOGENERATION
13SP	00ALL	TO->FROM	KELLY - MADISONCO 230.00 230KV CKT 1	192	192	0.768	128.6	129.1	ATC_B2_8E2
13SP	00G08_086N02	TO->FROM	KELLY - MADISONCO 230.00 230KV CKT 1	192	192	0.768	128.6	129.1	ATC_B2_8E2
13SP	00ALL	TO->FROM	KELLY - MADISONCO 230.00 230KV CKT 1	192	192	0.768	128.5	129.2	GEN542955 1-LACYGNE UNIT #1
13SP	00G08_086N02	TO->FROM	KELLY - MADISONCO 230.00 230KV CKT 1	192	192	0.768	128.5	129.2	GEN542955 1-LACYGNE UNIT #1
13SP	00ALL	TO->FROM	KELLY - MADISONCO 230.00 230KV CKT 1	192	192	0.768	128.5	129.4	FT RANDAL - WHITE SWAN 115KV CKT 1
13SP	00G08_086N02	TO->FROM	KELLY - MADISONCO 230.00 230KV CKT 1	192	192	0.768	128.5	129.4	FT RANDAL - WHITE SWAN 115KV CKT 1
13SP	00ALL	TO->FROM	KELLY - MADISONCO 230.00 230KV CKT 1	192	192	0.768	128.5	129.5	TYNDALL - WHITE SWAN 115KV CKT 1
13SP	00G08_086N02	TO->FROM	KELLY - MADISONCO 230.00 230KV CKT 1	192	192	0.768	128.5	129.5	TYNDALL - WHITE SWAN 115KV CKT 1
13SP	00ALL	TO->FROM	KELLY - MADISONCO 230.00 230KV CKT 1	192	192	0.768	128.4	129.6	FT THOMPSON - LETCHER 230KV CKT 1

Power Flow Analysis

Season	Dispatch Group	Flow	Overloaded Element	RATEA (MVA)	RATEB (MVA)	TDF	TC% LOADING	Max MW Available	Contingency
13SP	00G08_086N02	TO->FROM	KELLY - MADISONCO 230.00 230KV CKT 1	192	192	0.768	128.4	129.6	FT THOMPSON - LETCHER 230KV CKT 1
13SP	00ALL	TO->FROM	KELLY - MADISONCO 230.00 230KV CKT 1	192	192	0.768	128.4	129.7	GEN542956 2-LACYGNE UNIT #2
13SP	00G08_086N02	TO->FROM	KELLY - MADISONCO 230.00 230KV CKT 1	192	192	0.768	128.4	129.7	GEN542956 2-LACYGNE UNIT #2
13SP	00ALL	TO->FROM	KELLY - MADISONCO 230.00 230KV CKT 1	192	192	0.768	128.3	129.7	GEN525562 1-TOLK GEN #2 24 KV
13SP	00G08_086N02	TO->FROM	KELLY - MADISONCO 230.00 230KV CKT 1	192	192	0.768	128.3	129.7	GEN525562 1-TOLK GEN #2 24 KV
13SP	00ALL	TO->FROM	KELLY - MADISONCO 230.00 230KV CKT 1	192	192	0.768	128.3	129.8	SPLIT ROCK TAP - WHITE 345KV CKT 1
13SP	00G08_086N02	TO->FROM	KELLY - MADISONCO 230.00 230KV CKT 1	192	192	0.768	128.3	129.8	SPLIT ROCK TAP - WHITE 345KV CKT 1
13SP	00ALL	TO->FROM	KELLY - MADISONCO 230.00 230KV CKT 1	192	192	0.767	128.3	129.8	103RD & ROKEBY - SUB 3458 NEB CTY 345KV CKT 1
13SP	00G08_086N02	TO->FROM	KELLY - MADISONCO 230.00 230KV CKT 1	192	192	0.767	128.3	129.8	103RD & ROKEBY - SUB 3458 NEB CTY 345KV CKT 1
13SP	00ALL	TO->FROM	KELLY - MADISONCO 230.00 230KV CKT 1	192	192	0.770	128.4	129.8	RASMUSN - SIOUX CITY 230KV CKT 1
13SP	00G08_086N02	TO->FROM	KELLY - MADISONCO 230.00 230KV CKT 1	192	192	0.770	128.4	129.8	RASMUSN - SIOUX CITY 230KV CKT 1
13SP	00ALL	TO->FROM	KELLY - MADISONCO 230.00 230KV CKT 1	192	192	0.768	128.2	130	GEN531447 1-HOLCOMB GENERATOR
13SP	00G08_086N02	TO->FROM	KELLY - MADISONCO 230.00 230KV CKT 1	192	192	0.768	128.2	130	GEN531447 1-HOLCOMB GENERATOR
13SP	00ALL	TO->FROM	KELLY - MADISONCO 230.00 230KV CKT 1	192	192	0.768	128.2	130.1	GEN645001 1-FORT CALHOUN 1
13SP	00G08_086N02	TO->FROM	KELLY - MADISONCO 230.00 230KV CKT 1	192	192	0.768	128.2	130.1	GEN645001 1-FORT CALHOUN 1
13SP	00ALL	TO->FROM	KELLY - MADISONCO 230.00 230KV CKT 1	192	192	0.768	128.2	130.2	BLOOMFIELD - CREIGHTON 115KV CKT 1
13SP	00G08_086N02	TO->FROM	KELLY - MADISONCO 230.00 230KV CKT 1	192	192	0.768	128.2	130.2	BLOOMFIELD - CREIGHTON 115KV CKT 1
13SP	00ALL	TO->FROM	KELLY - MADISONCO 230.00 230KV CKT 1	192	192	0.768	128.1	130.2	GEN542951 5-HAWTHORN UNIT #5
13SP	00G08_086N02	TO->FROM	KELLY - MADISONCO 230.00 230KV CKT 1	192	192	0.768	128.1	130.2	GEN542951 5-HAWTHORN UNIT #5
13SP	00ALL	TO->FROM	KELLY - MADISONCO 230.00 230KV CKT 1	192	192	0.768	128.1	130.3	GEN525561 1-TOLK GEN #1 24 KV
13SP	00G08_086N02	TO->FROM	KELLY - MADISONCO 230.00 230KV CKT 1	192	192	0.768	128.1	130.3	GEN525561 1-TOLK GEN #1 24 KV
13SP	00ALL	TO->FROM	KELLY - MADISONCO 230.00 230KV CKT 1	192	192	0.768	128.1	130.3	DAK01WAPAB2
13SP	00G08_086N02	TO->FROM	KELLY - MADISONCO 230.00 230KV CKT 1	192	192	0.768	128.1	130.3	DAK01WAPAB2
13SP	00ALL	TO->FROM	KELLY - MADISONCO 230.00 230KV CKT 1	192	192	0.768	128.1	130.4	PAHOJA - SIOUX FALLS 230KV CKT 1
13SP	00G08_086N02	TO->FROM	KELLY - MADISONCO 230.00 230KV CKT 1	192	192	0.768	128.1	130.4	PAHOJA - SIOUX FALLS 230KV CKT 1
13SP	00ALL	TO->FROM	KELLY - MADISONCO 230.00 230KV CKT 1	192	192	0.770	128.1	130.6	UTICA JCT - VFODNES 230KV CKT 1
13SP	00G08_086N02	TO->FROM	KELLY - MADISONCO 230.00 230KV CKT 1	192	192	0.770	128.1	130.6	UTICA JCT - VFODNES 230KV CKT 1
13SP	00ALL	TO->FROM	KELLY - MADISONCO 230.00 230KV CKT 1	192	192	0.768	127.9	130.9	ARPIN - EAU CLAIRE 345KV CKT 1
13SP	00G08_086N02	TO->FROM	KELLY - MADISONCO 230.00 230KV CKT 1	192	192	0.768	127.9	130.9	ARPIN - EAU CLAIRE 345KV CKT 1
13SP	00ALL	TO->FROM	KELLY - MADISONCO 230.00 230KV CKT 1	192	192	0.768	127.8	131	SIDNEY - STEGALL 345KV CKT 1
13SP	00G08_086N02	TO->FROM	KELLY - MADISONCO 230.00 230KV CKT 1	192	192	0.768	127.8	131	SIDNEY - STEGALL 345KV CKT 1
13SP	00ALL	TO->FROM	KELLY - MADISONCO 230.00 230KV CKT 1	192	192	0.768	126.2	135	BASE CASE
13SP	00G08_086N02	TO->FROM	KELLY - MADISONCO 230.00 230KV CKT 1	192	192	0.768	126.2	135	BASE CASE
13SP	00ALL	TO->FROM	KELLY - MADISONCO 230.00 230KV CKT 1	192	192	0.767	124.6	138.9	FALLOW 3 345.00 - GRIMES 345KV CKT 1
13SP	00G08_086N02	TO->FROM	KELLY - MADISONCO 230.00 230KV CKT 1	192	192	0.767	124.6	138.9	FALLOW 3 345.00 - GRIMES 345KV CKT 1
13SP	00ALL	TO->FROM	KELLY - MADISONCO 230.00 230KV CKT 1	192	192	0.767	124.5	139.3	HOSKINS (HOSKINS T2) 345/230/13.8KV TRANSFORMER CKT 1
13SP	00G08_086N02	TO->FROM	KELLY - MADISONCO 230.00 230KV CKT 1	192	192	0.767	124.5	139.3	HOSKINS (HOSKINS T2) 345/230/13.8KV TRANSFORMER CKT 1

Power Flow Analysis

Season	Dispatch Group	Flow	Overloaded Element	RATEA (MVA)	RATEB (MVA)	TDF	TC% LOADING	Max MW Available	Contingency
13SP	00ALL	TO->FROM	KELLY - MADISONCO 230.00 230KV CKT 1	192	192	0.768	124.5	139.3	GEN652460 4-GARRISON
13SP	00G08_086N02	TO->FROM	KELLY - MADISONCO 230.00 230KV CKT 1	192	192	0.768	124.5	139.3	GEN652460 4-GARRISON
13SP	00ALL	TO->FROM	KELLY - MADISONCO 230.00 230KV CKT 1	192	192	0.766	124.4	139.4	ALBION - GENOA 115KV CKT 1
13SP	00G08_086N02	TO->FROM	KELLY - MADISONCO 230.00 230KV CKT 1	192	192	0.766	124.4	139.4	ALBION - GENOA 115KV CKT 1
13SP	00ALL	TO->FROM	KELLY - MADISONCO 230.00 230KV CKT 1	192	192	0.768	124.5	139.4	LN-1090
13SP	00G08_086N02	TO->FROM	KELLY - MADISONCO 230.00 230KV CKT 1	192	192	0.768	124.5	139.4	LN-1090
13SP	00ALL	TO->FROM	KELLY - MADISONCO 230.00 230KV CKT 1	192	192	0.768	124.5	139.4	AINSWORTH - CALAMUS 115KV CKT 1
13SP	00G08_086N02	TO->FROM	KELLY - MADISONCO 230.00 230KV CKT 1	192	192	0.768	124.5	139.4	AINSWORTH - CALAMUS 115KV CKT 1
13SP	00ALL	TO->FROM	KELLY - MADISONCO 230.00 230KV CKT 1	192	192	0.768	124.5	139.4	CALAMUS - THEDFORD 115KV CKT 1
13SP	00G08_086N02	TO->FROM	KELLY - MADISONCO 230.00 230KV CKT 1	192	192	0.768	124.5	139.4	CALAMUS - THEDFORD 115KV CKT 1
13SP	00ALL	TO->FROM	KELLY - MADISONCO 230.00 230KV CKT 1	192	192	0.768	124.4	139.6	GEN652457 1-GARRISON
13SP	00ALL	TO->FROM	KELLY - MADISONCO 230.00 230KV CKT 1	192	192	0.768	124.4	139.6	GEN652458 2-GARRISON
13SP	00ALL	TO->FROM	KELLY - MADISONCO 230.00 230KV CKT 1	192	192	0.768	124.4	139.6	GEN652459 3-GARRISON
13SP	00G08_086N02	TO->FROM	KELLY - MADISONCO 230.00 230KV CKT 1	192	192	0.768	124.4	139.6	GEN652457 1-GARRISON
13SP	00G08_086N02	TO->FROM	KELLY - MADISONCO 230.00 230KV CKT 1	192	192	0.768	124.4	139.6	GEN652458 2-GARRISON
13SP	00G08_086N02	TO->FROM	KELLY - MADISONCO 230.00 230KV CKT 1	192	192	0.768	124.4	139.6	GEN652459 3-GARRISON
13SP	00ALL	TO->FROM	KELLY - MADISONCO 230.00 230KV CKT 1	192	192	0.768	124.2	140.1	GEN652542 1-BIG BEND
13SP	00ALL	TO->FROM	KELLY - MADISONCO 230.00 230KV CKT 1	192	192	0.768	124.2	140.1	GEN652543 3-BIG BEND
13SP	00G08_086N02	TO->FROM	KELLY - MADISONCO 230.00 230KV CKT 1	192	192	0.768	124.2	140.1	GEN652542 1-BIG BEND
13SP	00G08_086N02	TO->FROM	KELLY - MADISONCO 230.00 230KV CKT 1	192	192	0.768	124.2	140.1	GEN652543 3-BIG BEND
13SP	00ALL	TO->FROM	KELLY - MADISONCO 230.00 230KV CKT 1	192	192	0.768	124.2	140.1	GEN652544 5-BIG BEND
13SP	00G08_086N02	TO->FROM	KELLY - MADISONCO 230.00 230KV CKT 1	192	192	0.768	124.2	140.1	GEN652544 5-BIG BEND
13SP	00ALL	TO->FROM	KELLY - MADISONCO 230.00 230KV CKT 1	192	192	0.768	124.2	140.1	ATCHSNT3 345.00 - COOPER 345KV CKT 1
13SP	00G08_086N02	TO->FROM	KELLY - MADISONCO 230.00 230KV CKT 1	192	192	0.768	124.2	140.1	ATCHSNT3 345.00 - COOPER 345KV CKT 1
13SP	00ALL	TO->FROM	KELLY - MADISONCO 230.00 230KV CKT 1	192	192	0.768	124.2	140.2	MAXWELL - THEDFORD 115KV CKT 1
13SP	00G08_086N02	TO->FROM	KELLY - MADISONCO 230.00 230KV CKT 1	192	192	0.768	124.2	140.2	MAXWELL - THEDFORD 115KV CKT 1
13SP	00ALL	TO->FROM	KELLY - MADISONCO 230.00 230KV CKT 1	192	192	0.767	124.1	140.2	LAKEFIELD 3 - RAUN 345KV CKT 1
13SP	00G08_086N02	TO->FROM	KELLY - MADISONCO 230.00 230KV CKT 1	192	192	0.767	124.1	140.2	LAKEFIELD 3 - RAUN 345KV CKT 1
13SP	00ALL	TO->FROM	KELLY - MADISONCO 230.00 230KV CKT 1	192	192	0.768	124.0	140.6	ATCHSNT3 345.00 - BOONEVILLE 345KV CKT 1
13SP	00G08_086N02	TO->FROM	KELLY - MADISONCO 230.00 230KV CKT 1	192	192	0.768	124.0	140.6	ATCHSNT3 345.00 - BOONEVILLE 345KV CKT 1
13SP	00ALL	TO->FROM	KELLY - MADISONCO 230.00 230KV CKT 1	192	192	0.768	123.9	140.8	AINSWORTH - AINSWORTH 115KV CKT 1
13SP	00G08_086N02	TO->FROM	KELLY - MADISONCO 230.00 230KV CKT 1	192	192	0.768	123.9	140.8	AINSWORTH - AINSWORTH 115KV CKT 1
13SP	00ALL	TO->FROM	KELLY - MADISONCO 230.00 230KV CKT 1	192	192	0.761	123.6	141.1	KELLY (KELLY T1) 230/115/13.2KV TRANSFORMER CKT 1
13SP	00G08_086N02	TO->FROM	KELLY - MADISONCO 230.00 230KV CKT 1	192	192	0.761	123.6	141.1	KELLY (KELLY T1) 230/115/13.2KV TRANSFORMER CKT 1
13SP	00ALL	TO->FROM	KELLY - MADISONCO 230.00 230KV CKT 1	192	192	0.761	123.6	141.1	TRF-KELLY
13SP	00G08_086N02	TO->FROM	KELLY - MADISONCO 230.00 230KV CKT 1	192	192	0.761	123.6	141.1	TRF-KELLY
13SP	00ALL	TO->FROM	KELLY - MADISONCO 230.00 230KV CKT 1	192	192	0.761	123.6	141.1	COLUMBUS - KELLY 115KV CKT 1

Power Flow Analysis

Season	Dispatch Group	Flow	Overloaded Element	RATEA (MVA)	RATEB (MVA)	TDF	TC% LOADING	Max MW Available	Contingency
13SP	00G08_086N02	TO->FROM	KELLY - MADISONCO 230.00 230KV CKT 1	192	192	0.761	123.6	141.1	COLUMBUS - KELLY 115KV CKT 1
13SP	00ALL	TO->FROM	KELLY - MADISONCO 230.00 230KV CKT 1	192	192	0.768	123.7	141.3	GEN652559 1-OAHE
13SP	00G08_086N02	TO->FROM	KELLY - MADISONCO 230.00 230KV CKT 1	192	192	0.768	123.7	141.3	GEN652559 1-OAHE
13SP	00ALL	TO->FROM	KELLY - MADISONCO 230.00 230KV CKT 1	192	192	0.768	123.7	141.3	STEGALL - WAYSIDE 230KV CKT 1
13SP	00G08_086N02	TO->FROM	KELLY - MADISONCO 230.00 230KV CKT 1	192	192	0.768	123.7	141.3	STEGALL - WAYSIDE 230KV CKT 1
13SP	00ALL	TO->FROM	KELLY - MADISONCO 230.00 230KV CKT 1	192	192	0.724	122.3	141.4	KELLY - SHELL CREEK 230KV CKT 1
13SP	00G08_086N02	TO->FROM	KELLY - MADISONCO 230.00 230KV CKT 1	192	192	0.724	122.3	141.4	KELLY - SHELL CREEK 230KV CKT 1
13SP	00ALL	TO->FROM	KELLY - MADISONCO 230.00 230KV CKT 1	192	192	0.724	122.3	141.4	SHELL CREEK (SHELLCREEKT1) 345/230/13.8KV TRANSFORMER CKT 1
13SP	00G08_086N02	TO->FROM	KELLY - MADISONCO 230.00 230KV CKT 1	192	192	0.724	122.3	141.4	SHELL CREEK (SHELLCREEKT1) 345/230/13.8KV TRANSFORMER CKT 1
13SP	00ALL	TO->FROM	KELLY - MADISONCO 230.00 230KV CKT 1	192	192	0.758	123.1	142	COLUMEAST (COL.EAST T3) 230/115/13.8KV TRANSFORMER CKT 1
13SP	00G08_086N02	TO->FROM	KELLY - MADISONCO 230.00 230KV CKT 1	192	192	0.758	123.1	142	COLUMEAST (COL.EAST T3) 230/115/13.8KV TRANSFORMER CKT 1
13SP	00ALL	TO->FROM	KELLY - MADISONCO 230.00 230KV CKT 1	192	192	0.758	123.1	142.1	COLUMEAST - KELLY 230KV CKT 1
13SP	00G08_086N02	TO->FROM	KELLY - MADISONCO 230.00 230KV CKT 1	192	192	0.758	123.1	142.1	COLUMEAST - KELLY 230KV CKT 1
13SP	00ALL	TO->FROM	KELLY - MADISONCO 230.00 230KV CKT 1	192	192	0.766	123.3	142.1	COLUMBUS - GENOA 115KV CKT 1
13SP	00G08_086N02	TO->FROM	KELLY - MADISONCO 230.00 230KV CKT 1	192	192	0.766	123.3	142.1	COLUMBUS - GENOA 115KV CKT 1
13SP	00ALL	TO->FROM	KELLY - MADISONCO 230.00 230KV CKT 1	192	192	0.768	123.3	142.4	GEN652556 2-OAHE
13SP	00ALL	TO->FROM	KELLY - MADISONCO 230.00 230KV CKT 1	192	192	0.768	123.3	142.4	GEN652557 4-OAHE
13SP	00ALL	TO->FROM	KELLY - MADISONCO 230.00 230KV CKT 1	192	192	0.768	123.3	142.4	GEN652558 6-OAHE
13SP	00G08_086N02	TO->FROM	KELLY - MADISONCO 230.00 230KV CKT 1	192	192	0.768	123.3	142.4	GEN652556 2-OAHE
13SP	00G08_086N02	TO->FROM	KELLY - MADISONCO 230.00 230KV CKT 1	192	192	0.768	123.3	142.4	GEN652557 4-OAHE
13SP	00G08_086N02	TO->FROM	KELLY - MADISONCO 230.00 230KV CKT 1	192	192	0.768	123.3	142.4	GEN652558 6-OAHE
13SP	00ALL	TO->FROM	KELLY - MADISONCO 230.00 230KV CKT 1	192	192	0.768	123.1	142.8	GEN652546 1-FT RANDAL
13SP	00G08_086N02	TO->FROM	KELLY - MADISONCO 230.00 230KV CKT 1	192	192	0.768	123.1	142.8	GEN652546 1-FT RANDAL
13SP	00ALL	TO->FROM	KELLY - MADISONCO 230.00 230KV CKT 1	192	192	0.768	122.7	143.9	GEN652547 3-FT RANDAL
13SP	00ALL	TO->FROM	KELLY - MADISONCO 230.00 230KV CKT 1	192	192	0.768	122.7	143.9	GEN652548 5-FT RANDAL
13SP	00ALL	TO->FROM	KELLY - MADISONCO 230.00 230KV CKT 1	192	192	0.768	122.7	143.9	GEN652549 7-FT RANDAL
13SP	00G08_086N02	TO->FROM	KELLY - MADISONCO 230.00 230KV CKT 1	192	192	0.768	122.7	143.9	GEN652547 3-FT RANDAL
13SP	00G08_086N02	TO->FROM	KELLY - MADISONCO 230.00 230KV CKT 1	192	192	0.768	122.7	143.9	GEN652548 5-FT RANDAL
13SP	00G08_086N02	TO->FROM	KELLY - MADISONCO 230.00 230KV CKT 1	192	192	0.768	122.7	143.9	GEN652549 7-FT RANDAL
13G	09G08_086N02	TO->FROM	KELLY - MADISONCO 230.00 230KV CKT 1	192	192	0.779	122.8	144.3	FT RANDAL - UTICA JCT 230KV CKT 1
13WP	00ALL	TO->FROM	KELLY - MADISONCO 230.00 230KV CKT 1	192	192	0.778	122.2	145.7	DAK02WAPAB2
13WP	00G08_086N02	TO->FROM	KELLY - MADISONCO 230.00 230KV CKT 1	192	192	0.778	122.2	145.7	DAK02WAPAB2
13SP	00ALL	TO->FROM	KELLY - MADISONCO 230.00 230KV CKT 1	192	192	0.748	121.4	145.8	HOSKINS - SHELL CREEK 345KV CKT 1
13SP	00G08_086N02	TO->FROM	KELLY - MADISONCO 230.00 230KV CKT 1	192	192	0.748	121.4	145.8	HOSKINS - SHELL CREEK 345KV CKT 1
13WP	00ALL	TO->FROM	KELLY - MADISONCO 230.00 230KV CKT 1	192	192	0.777	122.1	145.9	FT RANDAL - UTICA JCT 230KV CKT 1
13WP	00G08_086N02	TO->FROM	KELLY - MADISONCO 230.00 230KV CKT 1	192	192	0.777	122.1	145.9	FT RANDAL - UTICA JCT 230KV CKT 1
13SP	00ALL	TO->FROM	KELLY - MADISONCO 230.00 230KV CKT 1	192	192	0.768	121.8	146.2	GEN659110 1-LELAND OLDS UNIT1

Power Flow Analysis

Season	Dispatch Group	Flow	Overloaded Element	RATEA (MVA)	RATEB (MVA)	TDF	TC% LOADING	Max MW Available	Contingency
13SP	00G08_086N02	TO->FROM	KELLY - MADISONCO 230.00 230KV CKT 1	192	192	0.768	121.8	146.2	GEN659110 1-LELAND OLDS UNIT1
13G	09ALL	TO->FROM	KELLY - MADISONCO 230.00 230KV CKT 1	192	192	0.783	122.1	146.5	FT RANDAL - UTICA JCT 230KV CKT 1
13SP	00ALL	TO->FROM	KELLY - MADISONCO 230.00 230KV CKT 1	192	192	0.768	121.2	147.6	GEN659285 1-DEERCREEK 1G13.800
13SP	00G08_086N02	TO->FROM	KELLY - MADISONCO 230.00 230KV CKT 1	192	192	0.768	121.2	147.6	GEN659285 1-DEERCREEK 1G13.800
13SP	00ALL	TO->FROM	KELLY - MADISONCO 230.00 230KV CKT 1	192	192	0.774	120.5	149.7	FT RANDAL - LAKE PLATT 230KV CKT 1
13SP	00G08_086N02	TO->FROM	KELLY - MADISONCO 230.00 230KV CKT 1	192	192	0.774	120.5	149.7	FT RANDAL - LAKE PLATT 230KV CKT 1
13SP	00ALL	TO->FROM	KELLY - MADISONCO 230.00 230KV CKT 1	192	192	0.769	119.7	151.3	RAUN - SIOUX CITY 345KV CKT 1
13SP	00G08_086N02	TO->FROM	KELLY - MADISONCO 230.00 230KV CKT 1	192	192	0.769	119.7	151.3	RAUN - SIOUX CITY 345KV CKT 1
13SP	00ALL	TO->FROM	KELLY - MADISONCO 230.00 230KV CKT 1	192	192	0.774	119.7	151.7	FT RANDAL - FT THOMPSON 230KV CKT 1
13SP	00G08_086N02	TO->FROM	KELLY - MADISONCO 230.00 230KV CKT 1	192	192	0.774	119.7	151.7	FT RANDAL - FT THOMPSON 230KV CKT 1
13SP	00ALL	TO->FROM	KELLY - MADISONCO 230.00 230KV CKT 1	192	192	0.774	119.5	152.3	FT THOMPSON - LAKE PLATT 230KV CKT 1
13SP	00G08_086N02	TO->FROM	KELLY - MADISONCO 230.00 230KV CKT 1	192	192	0.774	119.5	152.3	FT THOMPSON - LAKE PLATT 230KV CKT 1
13G	09G08_086N02	TO->FROM	KELLY - MADISONCO 230.00 230KV CKT 1	192	192	0.776	118.7	154.3	FT RANDAL - SIOUX CITY 230KV CKT 1
13G	09ALL	TO->FROM	KELLY - MADISONCO 230.00 230KV CKT 1	192	192	0.781	118.2	156	FT RANDAL - SIOUX CITY 230KV CKT 1
13SP	00ALL	TO->FROM	KELLY - MADISONCO 230.00 230KV CKT 1	192	192	0.768	117.1	157.8	GEN659111 2-LELAND OLDS UNIT2
13SP	00G08_086N02	TO->FROM	KELLY - MADISONCO 230.00 230KV CKT 1	192	192	0.768	117.1	157.8	GEN659111 2-LELAND OLDS UNIT2
13WP	00ALL	TO->FROM	KELLY - MADISONCO 230.00 230KV CKT 1	192	192	0.775	116.7	159.2	FT RANDAL - SIOUX CITY 230KV CKT 1
13WP	00G08_086N02	TO->FROM	KELLY - MADISONCO 230.00 230KV CKT 1	192	192	0.775	116.7	159.2	FT RANDAL - SIOUX CITY 230KV CKT 1
13SP	00ALL	TO->FROM	KELLY - MADISONCO 230.00 230KV CKT 1	192	192	0.768	116.5	159.3	GEN659103 1-ANTELOPE VALLEY UNIT1
13SP	00ALL	TO->FROM	KELLY - MADISONCO 230.00 230KV CKT 1	192	192	0.768	116.5	159.3	GEN659107 2-ANTELOPE VALLEY UNIT2
13SP	00G08_086N02	TO->FROM	KELLY - MADISONCO 230.00 230KV CKT 1	192	192	0.768	116.5	159.3	GEN659103 1-ANTELOPE VALLEY UNIT1
13SP	00G08_086N02	TO->FROM	KELLY - MADISONCO 230.00 230KV CKT 1	192	192	0.768	116.5	159.3	GEN659107 2-ANTELOPE VALLEY UNIT2
13G	09G08_086N02	TO->FROM	KELLY - MADISONCO 230.00 230KV CKT 1	192	192	0.769	114.6	164.3	FT THOMPSON - GRAND ISLAND 345KV CKT 1
13WP	00ALL	TO->FROM	KELLY - MADISONCO 230.00 230KV CKT 1	192	192	0.745	113.7	165.4	COLUMWEST - GRAND ISLAND 230KV CKT 1
13WP	00G08_086N02	TO->FROM	KELLY - MADISONCO 230.00 230KV CKT 1	192	192	0.745	113.7	165.4	COLUMWEST - GRAND ISLAND 230KV CKT 1
13G	09G08_086N02	TO->FROM	KELLY - MADISONCO 230.00 230KV CKT 1	192	192	0.754	113.7	165.6	COLUMEAST - NW68TH & HOLDREGE 345KV CKT 1
13G	09G08_086N02	TO->FROM	KELLY - MADISONCO 230.00 230KV CKT 1	192	192	0.769	113.9	165.8	GEN640009 1-COOPER NUCLEAR STATION
13G	09G08_086N02	TO->FROM	KELLY - MADISONCO 230.00 230KV CKT 1	192	192	0.769	113.6	166.7	GEN645012 2-NEBRASKA CITY 2
13WP	00ALL	TO->FROM	KELLY - MADISONCO 230.00 230KV CKT 1	192	192	0.752	113.0	167.5	COLUMEAST - NW68TH & HOLDREGE 345KV CKT 1
13WP	00G08_086N02	TO->FROM	KELLY - MADISONCO 230.00 230KV CKT 1	192	192	0.752	113.0	167.5	COLUMEAST - NW68TH & HOLDREGE 345KV CKT 1
13G	09G08_086N02	TO->FROM	KELLY - MADISONCO 230.00 230KV CKT 1	192	192	0.769	113.2	167.5	GEN645011 1-NEBRASKA CITY 1
13G	09G08_086N02	TO->FROM	KELLY - MADISONCO 230.00 230KV CKT 1	192	192	0.745	112.7	167.9	COLUMWEST - GRAND ISLAND 230KV CKT 1
13G	09ALL	TO->FROM	KELLY - MADISONCO 230.00 230KV CKT 1	192	192	0.769	113.0	168.1	GEN640009 1-COOPER NUCLEAR STATION
13G	09G08_086N02	TO->FROM	KELLY - MADISONCO 230.00 230KV CKT 1	192	192	0.769	113.0	168.2	GEN532751 1-WOLF CREEK GENERATING STATION UNIT 1
13G	09ALL	TO->FROM	KELLY - MADISONCO 230.00 230KV CKT 1	192	192	0.774	113.0	168.3	GEN640009 1-COOPER NUCLEAR STATION
13G	09G08_086N02	TO->FROM	KELLY - MADISONCO 230.00 230KV CKT 1	192	192	0.759	112.7	168.4	HOSKINS - RAUN 345KV CKT 1
13G	09G08_086N02	TO->FROM	KELLY - MADISONCO 230.00 230KV CKT 1	192	192	0.769	112.8	168.7	NEB02WAPAB2

Power Flow Analysis

Season	Dispatch Group	Flow	Overloaded Element	RATEA (MVA)	RATEB (MVA)	TDF	TC% LOADING	Max MW Available	Contingency
13G	09G08_086N02	TO->FROM	KELLY - MADISONCO 230.00 230KV CKT 1	192	192	0.771	112.8	168.8	RASMUSN - UTICA JCT 230KV CKT 1
13G	09G08_086N02	TO->FROM	KELLY - MADISONCO 230.00 230KV CKT 1	192	192	0.769	112.7	168.8	GAVINS POINT - HARTINGTON 115KV CKT 1
13G	09ALL	TO->FROM	KELLY - MADISONCO 230.00 230KV CKT 1	192	192	0.769	112.7	169	GEN645012 2-NEBRASKA CITY 2
13WP	00ALL	TO->FROM	KELLY - MADISONCO 230.00 230KV CKT 1	192	192	0.768	112.6	169.2	FT THOMPSON - GRAND ISLAND 345KV CKT 1
13WP	00G08_086N02	TO->FROM	KELLY - MADISONCO 230.00 230KV CKT 1	192	192	0.768	112.6	169.2	FT THOMPSON - GRAND ISLAND 345KV CKT 1
13G	09ALL	TO->FROM	KELLY - MADISONCO 230.00 230KV CKT 1	192	192	0.774	112.7	169.2	GEN645012 2-NEBRASKA CITY 2
13G	09G08_086N02	TO->FROM	KELLY - MADISONCO 230.00 230KV CKT 1	192	192	0.771	112.5	169.4	UTICA JCT - VFODNES 230KV CKT 1
13G	09G08_086N02	TO->FROM	KELLY - MADISONCO 230.00 230KV CKT 1	192	192	0.769	112.4	169.7	GEN640028 1-COLUMCOGENERATION
13G	09G08_086N02	TO->FROM	KELLY - MADISONCO 230.00 230KV CKT 1	192	192	0.769	112.4	169.8	GEN542962 2-IATAN UNIT #2
13G	09G08_086N02	TO->FROM	KELLY - MADISONCO 230.00 230KV CKT 1	192	192	0.768	112.3	169.8	PETERSBRG.N7115.00 - PETERSBURG 115KV CKT 1
13G	09ALL	TO->FROM	KELLY - MADISONCO 230.00 230KV CKT 1	192	192	0.769	112.3	169.8	GEN645011 1-NEBRASKA CITY 1
13G	09G08_086N02	TO->FROM	KELLY - MADISONCO 230.00 230KV CKT 1	192	192	0.768	112.3	169.9	ALBION - PETERSBURG 115KV CKT 1
13G	09ALL	TO->FROM	KELLY - MADISONCO 230.00 230KV CKT 1	192	192	0.774	112.3	170	GEN645011 1-NEBRASKA CITY 1
13G	09G08_086N02	TO->FROM	KELLY - MADISONCO 230.00 230KV CKT 1	192	192	0.771	112.2	170.3	RASMUSN - SIOUX CITY 230KV CKT 1
13G	09ALL	TO->FROM	KELLY - MADISONCO 230.00 230KV CKT 1	192	192	0.772	112.1	170.4	RASMUSN - UTICA JCT 230KV CKT 1
13G	09ALL	TO->FROM	KELLY - MADISONCO 230.00 230KV CKT 1	192	192	0.769	112.0	170.6	GEN532751 1-WOLF CREEK GENERATING STATION UNIT 1
13WP	00ALL	TO->FROM	KELLY - MADISONCO 230.00 230KV CKT 1	192	192	0.768	112.0	170.6	GEN640009 1-COOPER NUCLEAR STATION
13WP	00G08_086N02	TO->FROM	KELLY - MADISONCO 230.00 230KV CKT 1	192	192	0.768	112.0	170.6	GEN640009 1-COOPER NUCLEAR STATION
13G	09G08_086N02	TO->FROM	KELLY - MADISONCO 230.00 230KV CKT 1	192	192	0.769	112.0	170.6	GEN532651 1-JEFFREY ENERGY CENTER UNIT 1
13G	09G08_086N02	TO->FROM	KELLY - MADISONCO 230.00 230KV CKT 1	192	192	0.769	112.0	170.7	GEN532652 1-JEFFREY ENERGY CENTER UNIT 2
13G	09G08_086N02	TO->FROM	KELLY - MADISONCO 230.00 230KV CKT 1	192	192	0.769	112.0	170.7	GEN532653 1-JEFFREY ENERGY CENTER UNIT 3
13G	09ALL	TO->FROM	KELLY - MADISONCO 230.00 230KV CKT 1	192	192	0.745	111.6	170.7	COLUMWEST - GRAND ISLAND 230KV CKT 1
13G	09ALL	TO->FROM	KELLY - MADISONCO 230.00 230KV CKT 1	192	192	0.774	112.0	170.7	GEN532751 1-WOLF CREEK GENERATING STATION UNIT 1
13G	09G08_086N02	TO->FROM	KELLY - MADISONCO 230.00 230KV CKT 1	192	192	0.769	111.9	170.9	HANLON - STORLA 230KV CKT 1
13G	09G08_086N02	TO->FROM	KELLY - MADISONCO 230.00 230KV CKT 1	192	192	0.769	111.9	170.9	KEYSTONE - SIDNEY 345KV CKT 1
13G	09G08_086N02	TO->FROM	KELLY - MADISONCO 230.00 230KV CKT 1	192	192	0.768	111.8	171.2	103RD & ROKEBY - SUB 3458 NEB CTY 345KV CKT 1
13G	09G08_086N02	TO->FROM	KELLY - MADISONCO 230.00 230KV CKT 1	192	192	0.769	111.7	171.3	GEN542957 1-IATAN UNIT #1
13G	09G08_086N02	TO->FROM	KELLY - MADISONCO 230.00 230KV CKT 1	192	192	0.769	111.6	171.6	GEN640010 1-GERALD GENTLEMAN STATION UNIT 1
13G	09G08_086N02	TO->FROM	KELLY - MADISONCO 230.00 230KV CKT 1	192	192	0.769	111.6	171.6	GEN645001 1-FORT CALHOUN 1
13G	09G08_086N02	TO->FROM	KELLY - MADISONCO 230.00 230KV CKT 1	192	192	0.769	111.6	171.6	GEN640011 2-GERALD GENTLEMAN STATION UNIT 2
13WP	00ALL	TO->FROM	KELLY - MADISONCO 230.00 230KV CKT 1	192	192	0.768	111.6	171.6	GEN645012 2-NEBRASKA CITY 2
13WP	00G08_086N02	TO->FROM	KELLY - MADISONCO 230.00 230KV CKT 1	192	192	0.768	111.6	171.6	GEN645012 2-NEBRASKA CITY 2
13G	09G08_086N02	TO->FROM	KELLY - MADISONCO 230.00 230KV CKT 1	192	192	0.770	111.6	171.7	SIOUX FALLS - SPLIT ROCK 230KV CKT 1
13WP	00ALL	TO->FROM	KELLY - MADISONCO 230.00 230KV CKT 1	192	192	0.757	111.4	171.8	HOSKINS - RAUN 345KV CKT 1
13WP	00G08_086N02	TO->FROM	KELLY - MADISONCO 230.00 230KV CKT 1	192	192	0.757	111.4	171.8	HOSKINS - RAUN 345KV CKT 1
13G	09G08_086N02	TO->FROM	KELLY - MADISONCO 230.00 230KV CKT 1	192	192	0.770	111.5	171.9	LN-WAPA6
13G	09G08_086N02	TO->FROM	KELLY - MADISONCO 230.00 230KV CKT 1	192	192	0.770	111.5	171.9	NEB001NPPB2



Power Flow Analysis

Season	Dispatch Group	Flow	Overloaded Element	RATEA (MVA)	RATEB (MVA)	TDF	TC% LOADING	Max MW Available	Contingency
13G	09ALL	TO->FROM	KELLY - MADISONCO 230.00 230KV CKT 1	192	192	0.772	111.5	171.9	RASMUSN - SIOUX CITY 230KV CKT 1
13G	09G08_086N02	TO->FROM	KELLY - MADISONCO 230.00 230KV CKT 1	192	192	0.769	111.5	172	GEN525562 1-TOLK GEN #2 24 KV
13G	09G08_086N02	TO->FROM	KELLY - MADISONCO 230.00 230KV CKT 1	192	192	0.770	111.5	172	FT RANDAL - SPENCER 115KV CKT 1
13G	09ALL	TO->FROM	KELLY - MADISONCO 230.00 230KV CKT 1	192	192	0.769	111.4	172.1	GEN542962 2-IATAN UNIT #2
13G	09G08_086N02	TO->FROM	KELLY - MADISONCO 230.00 230KV CKT 1	192	192	0.769	111.4	172.1	GEN531447 1-HOLCOMB GENERATOR
13G	09G08_086N02	TO->FROM	KELLY - MADISONCO 230.00 230KV CKT 1	192	192	0.770	111.4	172.1	ATC_B2_8E2
13WP	00ALL	TO->FROM	KELLY - MADISONCO 230.00 230KV CKT 1	192	192	0.768	111.4	172.1	GEN645011 1-NEBRASKA CITY 1
13WP	00G08_086N02	TO->FROM	KELLY - MADISONCO 230.00 230KV CKT 1	192	192	0.768	111.4	172.1	GEN645011 1-NEBRASKA CITY 1
13G	09G08_086N02	TO->FROM	KELLY - MADISONCO 230.00 230KV CKT 1	192	192	0.771	111.4	172.1	SIOUX FALLS - VFODNES 230KV CKT 1
13G	09ALL	TO->FROM	KELLY - MADISONCO 230.00 230KV CKT 1	192	192	0.769	111.4	172.1	GEN640028 1-COLUMCOGENERATION
13G	09ALL	TO->FROM	KELLY - MADISONCO 230.00 230KV CKT 1	192	192	0.774	111.4	172.2	GEN542962 2-IATAN UNIT #2
13G	09G08_086N02	TO->FROM	KELLY - MADISONCO 230.00 230KV CKT 1	192	192	0.770	111.4	172.2	ONEILL - SPENCER 115KV CKT 1
13G	09ALL	TO->FROM	KELLY - MADISONCO 230.00 230KV CKT 1	192	192	0.774	111.4	172.3	GEN640028 1-COLUMCOGENERATION
13WP	00ALL	TO->FROM	KELLY - MADISONCO 230.00 230KV CKT 1	192	192	0.769	111.3	172.4	LN-WAPA6
13WP	00ALL	TO->FROM	KELLY - MADISONCO 230.00 230KV CKT 1	192	192	0.769	111.3	172.4	NEB001NPPB2
13WP	00G08_086N02	TO->FROM	KELLY - MADISONCO 230.00 230KV CKT 1	192	192	0.769	111.3	172.4	LN-WAPA6
13WP	00G08_086N02	TO->FROM	KELLY - MADISONCO 230.00 230KV CKT 1	192	192	0.769	111.3	172.4	NEB001NPPB2
13WP	00ALL	TO->FROM	KELLY - MADISONCO 230.00 230KV CKT 1	192	192	0.769	111.2	172.6	FT RANDAL - SPENCER 115KV CKT 1
13WP	00G08_086N02	TO->FROM	KELLY - MADISONCO 230.00 230KV CKT 1	192	192	0.769	111.2	172.6	FT RANDAL - SPENCER 115KV CKT 1
13G	09ALL	TO->FROM	KELLY - MADISONCO 230.00 230KV CKT 1	192	192	0.769	111.1	172.9	GEN532651 1-JEFFREY ENERGY CENTER UNIT 1
13G	09ALL	TO->FROM	KELLY - MADISONCO 230.00 230KV CKT 1	192	192	0.769	111.1	173	GEN532652 1-JEFFREY ENERGY CENTER UNIT 2
13G	09ALL	TO->FROM	KELLY - MADISONCO 230.00 230KV CKT 1	192	192	0.769	111.1	173	GEN532653 1-JEFFREY ENERGY CENTER UNIT 3
13WP	00ALL	TO->FROM	KELLY - MADISONCO 230.00 230KV CKT 1	192	192	0.768	111.0	173.1	GEN532751 1-WOLF CREEK GENERATING STATION UNIT 1
13WP	00G08_086N02	TO->FROM	KELLY - MADISONCO 230.00 230KV CKT 1	192	192	0.768	111.0	173.1	GEN532751 1-WOLF CREEK GENERATING STATION UNIT 1
13G	09ALL	TO->FROM	KELLY - MADISONCO 230.00 230KV CKT 1	192	192	0.774	111.1	173.1	GEN532651 1-JEFFREY ENERGY CENTER UNIT 1
13G	09ALL	TO->FROM	KELLY - MADISONCO 230.00 230KV CKT 1	192	192	0.769	111.0	173.1	HANLON - STORLA 230KV CKT 1
13G	09ALL	TO->FROM	KELLY - MADISONCO 230.00 230KV CKT 1	192	192	0.774	111.1	173.1	GEN532652 1-JEFFREY ENERGY CENTER UNIT 2
13G	09ALL	TO->FROM	KELLY - MADISONCO 230.00 230KV CKT 1	192	192	0.774	111.1	173.1	GEN532653 1-JEFFREY ENERGY CENTER UNIT 3
13G	09ALL	TO->FROM	KELLY - MADISONCO 230.00 230KV CKT 1	192	192	0.769	110.8	173.6	GEN542957 1-IATAN UNIT #1
13G	09ALL	TO->FROM	KELLY - MADISONCO 230.00 230KV CKT 1	192	192	0.770	110.8	173.6	SIOUX FALLS - SPLIT ROCK 230KV CKT 1
13G	09ALL	TO->FROM	KELLY - MADISONCO 230.00 230KV CKT 1	192	192	0.774	110.8	173.8	GEN542957 1-IATAN UNIT #1
13WP	00ALL	TO->FROM	KELLY - MADISONCO 230.00 230KV CKT 1	192	192	0.769	110.7	173.8	ONEILL - SPENCER 115KV CKT 1
13WP	00G08_086N02	TO->FROM	KELLY - MADISONCO 230.00 230KV CKT 1	192	192	0.769	110.7	173.8	ONEILL - SPENCER 115KV CKT 1
13WP	00ALL	TO->FROM	KELLY - MADISONCO 230.00 230KV CKT 1	192	192	0.745	110.4	173.9	COLUMWEST - KELLY 230KV CKT 1
13WP	00G08_086N02	TO->FROM	KELLY - MADISONCO 230.00 230KV CKT 1	192	192	0.745	110.4	173.9	COLUMWEST - KELLY 230KV CKT 1
13G	09ALL	TO->FROM	KELLY - MADISONCO 230.00 230KV CKT 1	192	192	0.769	110.7	174	GEN640011 2-GERALD GENTLEMAN STATION UNIT 2
13G	09ALL	TO->FROM	KELLY - MADISONCO 230.00 230KV CKT 1	192	192	0.768	110.6	174	103RD & ROKEBY - SUB 3458 NEB CTY 345KV CKT 1

Power Flow Analysis

Season	Dispatch Group	Flow	Overloaded Element	RATEA (MVA)	RATEB (MVA)	TDF	TC% LOADING	Max MW Available	Contingency
13G	09ALL	TO->FROM	KELLY - MADISONCO 230.00 230KV CKT 1	192	192	0.774	110.7	174	GEN640010 1-GERALD GENTLEMAN STATION UNIT 1
13G	09ALL	TO->FROM	KELLY - MADISONCO 230.00 230KV CKT 1	192	192	0.774	110.7	174.1	GEN640011 2-GERALD GENTLEMAN STATION UNIT 2
13G	09ALL	TO->FROM	KELLY - MADISONCO 230.00 230KV CKT 1	192	192	0.770	110.6	174.2	ATC_B2_8E2
13G	09ALL	TO->FROM	KELLY - MADISONCO 230.00 230KV CKT 1	192	192	0.769	110.6	174.2	GEN525562 1-TOLK GEN #2 24 KV
13G	09ALL	TO->FROM	KELLY - MADISONCO 230.00 230KV CKT 1	192	192	0.769	110.5	174.4	GEN531447 1-HOLCOMB GENERATOR
13G	09ALL	TO->FROM	KELLY - MADISONCO 230.00 230KV CKT 1	192	192	0.774	110.6	174.4	GEN645001 1-FORT CALHOUN 1
13G	09ALL	TO->FROM	KELLY - MADISONCO 230.00 230KV CKT 1	192	192	0.774	110.6	174.4	GEN525562 1-TOLK GEN #2 24 KV
13G	09ALL	TO->FROM	KELLY - MADISONCO 230.00 230KV CKT 1	192	192	0.774	110.5	174.5	GEN531447 1-HOLCOMB GENERATOR
13WP	00ALL	TO->FROM	KELLY - MADISONCO 230.00 230KV CKT 1	192	192	0.768	110.3	174.8	NEB02WAPAB2
13WP	00G08_086N02	TO->FROM	KELLY - MADISONCO 230.00 230KV CKT 1	192	192	0.768	110.3	174.8	NEB02WAPAB2
13WP	00ALL	TO->FROM	KELLY - MADISONCO 230.00 230KV CKT 1	192	192	0.770	110.3	175	RASMUSN - UTICA JCT 230KV CKT 1
13WP	00G08_086N02	TO->FROM	KELLY - MADISONCO 230.00 230KV CKT 1	192	192	0.770	110.3	175	RASMUSN - UTICA JCT 230KV CKT 1
13WP	00ALL	TO->FROM	KELLY - MADISONCO 230.00 230KV CKT 1	192	192	0.768	110.2	175.1	GEN542962 2-IATAN UNIT #2
13WP	00G08_086N02	TO->FROM	KELLY - MADISONCO 230.00 230KV CKT 1	192	192	0.768	110.2	175.1	GEN542962 2-IATAN UNIT #2
13WP	00ALL	TO->FROM	KELLY - MADISONCO 230.00 230KV CKT 1	192	192	0.768	110.2	175.2	HANLON - STORLA 230KV CKT 1
13WP	00G08_086N02	TO->FROM	KELLY - MADISONCO 230.00 230KV CKT 1	192	192	0.768	110.2	175.2	HANLON - STORLA 230KV CKT 1
13WP	00ALL	TO->FROM	KELLY - MADISONCO 230.00 230KV CKT 1	192	192	0.768	110.1	175.3	GAVINS POINT - HARTINGTON 115KV CKT 1
13WP	00G08_086N02	TO->FROM	KELLY - MADISONCO 230.00 230KV CKT 1	192	192	0.768	110.1	175.3	GAVINS POINT - HARTINGTON 115KV CKT 1
13WP	00ALL	TO->FROM	KELLY - MADISONCO 230.00 230KV CKT 1	192	192	0.768	110.0	175.5	GEN640028 1-COLUMCOGENERATION
13WP	00G08_086N02	TO->FROM	KELLY - MADISONCO 230.00 230KV CKT 1	192	192	0.768	110.0	175.5	GEN640028 1-COLUMCOGENERATION
13WP	00ALL	TO->FROM	KELLY - MADISONCO 230.00 230KV CKT 1	192	192	0.770	110.0	175.6	UTICA JCT - VFODNES 230KV CKT 1
13WP	00G08_086N02	TO->FROM	KELLY - MADISONCO 230.00 230KV CKT 1	192	192	0.770	110.0	175.6	UTICA JCT - VFODNES 230KV CKT 1
13WP	00ALL	TO->FROM	KELLY - MADISONCO 230.00 230KV CKT 1	192	192	0.769	110.0	175.7	ATC_B2_8E2
13WP	00G08_086N02	TO->FROM	KELLY - MADISONCO 230.00 230KV CKT 1	192	192	0.769	110.0	175.7	ATC_B2_8E2
13WP	00ALL	TO->FROM	KELLY - MADISONCO 230.00 230KV CKT 1	192	192	0.768	109.9	175.7	GEN532651 1-JEFFREY ENERGY CENTER UNIT 1
13WP	00G08_086N02	TO->FROM	KELLY - MADISONCO 230.00 230KV CKT 1	192	192	0.768	109.9	175.7	GEN532651 1-JEFFREY ENERGY CENTER UNIT 1
13WP	00ALL	TO->FROM	KELLY - MADISONCO 230.00 230KV CKT 1	192	192	0.768	109.9	175.8	GEN532653 1-JEFFREY ENERGY CENTER UNIT 3
13WP	00G08_086N02	TO->FROM	KELLY - MADISONCO 230.00 230KV CKT 1	192	192	0.768	109.9	175.8	GEN532653 1-JEFFREY ENERGY CENTER UNIT 3
13WP	00ALL	TO->FROM	KELLY - MADISONCO 230.00 230KV CKT 1	192	192	0.768	109.9	175.8	GEN532652 1-JEFFREY ENERGY CENTER UNIT 2
13WP	00G08_086N02	TO->FROM	KELLY - MADISONCO 230.00 230KV CKT 1	192	192	0.768	109.9	175.8	GEN532652 1-JEFFREY ENERGY CENTER UNIT 2
13WP	00ALL	TO->FROM	KELLY - MADISONCO 230.00 230KV CKT 1	192	192	0.768	109.9	175.9	KEYSTONE - SIDNEY 345KV CKT 1
13WP	00G08_086N02	TO->FROM	KELLY - MADISONCO 230.00 230KV CKT 1	192	192	0.768	109.9	175.9	KEYSTONE - SIDNEY 345KV CKT 1
13WP	00ALL	TO->FROM	KELLY - MADISONCO 230.00 230KV CKT 1	192	192	0.768	109.9	176	GEN641089 2-ENERGY CENTER 2
13WP	00G08_086N02	TO->FROM	KELLY - MADISONCO 230.00 230KV CKT 1	192	192	0.768	109.9	176	GEN641089 2-ENERGY CENTER 2
13G	09G08_086N02	TO->FROM	KELLY - MADISONCO 230.00 230KV CKT 1	192	192	0.769	109.7	176.3	BASE CASE
13G	09G08_086N02	TO->FROM	KELLY - MADISONCO 230.00 230KV CKT 1	192	192	0.769	109.7	176.3	NC1_GEN-NEBRASKA CITY 1
13WP	00ALL	TO->FROM	KELLY - MADISONCO 230.00 230KV CKT 1	192	192	0.768	109.6	176.5	GEN542957 1-IATAN UNIT #1

Power Flow Analysis

Season	Dispatch Group	Flow	Overloaded Element	RATEA (MVA)	RATEB (MVA)	TDF	TC% LOADING	Max MW Available	Contingency
13WP	00G08_086N02	TO->FROM	KELLY - MADISONCO 230.00 230KV CKT 1	192	192	0.768	109.6	176.5	GEN542957 1-IATAN UNIT #1
13WP	00ALL	TO->FROM	KELLY - MADISONCO 230.00 230KV CKT 1	192	192	0.768	109.6	176.6	FT THOMPSON - LETCHER 230KV CKT 1
13WP	00G08_086N02	TO->FROM	KELLY - MADISONCO 230.00 230KV CKT 1	192	192	0.768	109.6	176.6	FT THOMPSON - LETCHER 230KV CKT 1
13WP	00ALL	TO->FROM	KELLY - MADISONCO 230.00 230KV CKT 1	192	192	0.769	109.5	176.9	FT RANDAL - WHITE SWAN 115KV CKT 1
13WP	00G08_086N02	TO->FROM	KELLY - MADISONCO 230.00 230KV CKT 1	192	192	0.769	109.5	176.9	FT RANDAL - WHITE SWAN 115KV CKT 1
13WP	00ALL	TO->FROM	KELLY - MADISONCO 230.00 230KV CKT 1	192	192	0.768	109.5	177	GEN645001 1-FORT CALHOUN 1
13WP	00G08_086N02	TO->FROM	KELLY - MADISONCO 230.00 230KV CKT 1	192	192	0.768	109.5	177	GEN645001 1-FORT CALHOUN 1
13WP	00ALL	TO->FROM	KELLY - MADISONCO 230.00 230KV CKT 1	192	192	0.769	109.5	177	TYNDALL - WHITE SWAN 115KV CKT 1
13WP	00G08_086N02	TO->FROM	KELLY - MADISONCO 230.00 230KV CKT 1	192	192	0.769	109.5	177	TYNDALL - WHITE SWAN 115KV CKT 1
13WP	00ALL	TO->FROM	KELLY - MADISONCO 230.00 230KV CKT 1	192	192	0.768	109.4	177.1	GEN525562 1-TOLK GEN #2 24 KV
13WP	00G08_086N02	TO->FROM	KELLY - MADISONCO 230.00 230KV CKT 1	192	192	0.768	109.4	177.1	GEN525562 1-TOLK GEN #2 24 KV
13WP	00ALL	TO->FROM	KELLY - MADISONCO 230.00 230KV CKT 1	192	192	0.770	109.4	177.1	RASMUSN - SIOUX CITY 230KV CKT 1
13WP	00G08_086N02	TO->FROM	KELLY - MADISONCO 230.00 230KV CKT 1	192	192	0.770	109.4	177.1	RASMUSN - SIOUX CITY 230KV CKT 1
13WP	00ALL	TO->FROM	KELLY - MADISONCO 230.00 230KV CKT 1	192	192	0.768	109.4	177.2	DAK01WAPAB2
13WP	00G08_086N02	TO->FROM	KELLY - MADISONCO 230.00 230KV CKT 1	192	192	0.768	109.4	177.2	DAK01WAPAB2
13WP	00ALL	TO->FROM	KELLY - MADISONCO 230.00 230KV CKT 1	192	192	0.769	109.4	177.2	SIOUX FALLS - SPLIT ROCK 230KV CKT 1
13WP	00G08_086N02	TO->FROM	KELLY - MADISONCO 230.00 230KV CKT 1	192	192	0.769	109.4	177.2	SIOUX FALLS - SPLIT ROCK 230KV CKT 1
13WP	00ALL	TO->FROM	KELLY - MADISONCO 230.00 230KV CKT 1	192	192	0.766	109.3	177.3	SIOUX CITY - TWIN CHURCH 230KV CKT 1
13WP	00G08_086N02	TO->FROM	KELLY - MADISONCO 230.00 230KV CKT 1	192	192	0.766	109.3	177.3	SIOUX CITY - TWIN CHURCH 230KV CKT 1
13WP	00ALL	TO->FROM	KELLY - MADISONCO 230.00 230KV CKT 1	192	192	0.768	109.3	177.4	GEN531447 1-HOLCOMB GENERATOR
13WP	00G08_086N02	TO->FROM	KELLY - MADISONCO 230.00 230KV CKT 1	192	192	0.768	109.3	177.4	GEN531447 1-HOLCOMB GENERATOR
13WP	00ALL	TO->FROM	KELLY - MADISONCO 230.00 230KV CKT 1	192	192	0.768	109.2	177.5	GEN542955 1-LACYGNE UNIT #1
13WP	00G08_086N02	TO->FROM	KELLY - MADISONCO 230.00 230KV CKT 1	192	192	0.768	109.2	177.5	GEN542955 1-LACYGNE UNIT #1
13WP	00ALL	TO->FROM	KELLY - MADISONCO 230.00 230KV CKT 1	192	192	0.767	109.2	177.6	103RD & ROKEBY - SUB 3458 NEB CTY 345KV CKT 1
13WP	00G08_086N02	TO->FROM	KELLY - MADISONCO 230.00 230KV CKT 1	192	192	0.767	109.2	177.6	103RD & ROKEBY - SUB 3458 NEB CTY 345KV CKT 1
13WP	00ALL	TO->FROM	KELLY - MADISONCO 230.00 230KV CKT 1	192	192	0.768	109.2	177.7	GEN525561 1-TOLK GEN #1 24 KV
13WP	00G08_086N02	TO->FROM	KELLY - MADISONCO 230.00 230KV CKT 1	192	192	0.768	109.2	177.7	GEN525561 1-TOLK GEN #1 24 KV
13WP	00ALL	TO->FROM	KELLY - MADISONCO 230.00 230KV CKT 1	192	192	0.768	109.2	177.7	GEN542956 2-LACYGNE UNIT #2
13WP	00G08_086N02	TO->FROM	KELLY - MADISONCO 230.00 230KV CKT 1	192	192	0.768	109.2	177.7	GEN542956 2-LACYGNE UNIT #2
13G	09ALL	TO->FROM	KELLY - MADISONCO 230.00 230KV CKT 1	192	192	0.769	108.8	178.5	BASE CASE
13G	09ALL	TO->FROM	KELLY - MADISONCO 230.00 230KV CKT 1	192	192	0.769	108.8	178.5	NC1_GEN-NEBRASKA CITY 1
13G	09ALL	TO->FROM	KELLY - MADISONCO 230.00 230KV CKT 1	192	192	0.774	108.8	178.5	BASE CASE
13G	09G08_086N02	TO->FROM	KELLY - MADISONCO 230.00 230KV CKT 1	192	192	0.768	108.2	179.6	NELIGH - PETERSBRG.N7115.00 115KV CKT 1
13G	09G08_086N02	TO->FROM	KELLY - MADISONCO 230.00 230KV CKT 1	192	192	0.769	108.1	180.2	FALLOW 3 345.00 - GRIMES 345KV CKT 1
13G	09G08_086N02	TO->FROM	KELLY - MADISONCO 230.00 230KV CKT 1	192	192	0.775	108.1	180.4	FT RANDAL - FT THOMPSON 230KV CKT 1
13G	09G08_086N02	TO->FROM	KELLY - MADISONCO 230.00 230KV CKT 1	192	192	0.771	108.0	180.5	RAUN - SUB 3451 FT CAL 345KV CKT 1
13G	09G08_086N02	TO->FROM	KELLY - MADISONCO 230.00 230KV CKT 1	192	192	0.769	107.9	180.7	BLOOMFIELD - GAVINS POINT 115KV CKT 1

Power Flow Analysis

Season	Dispatch Group	Flow	Overloaded Element	RATEA (MVA)	RATEB (MVA)	TDF	TC% LOADING	Max MW Available	Contingency
13G	09G08_086N02	TO->FROM	KELLY - MADISONCO 230.00 230KV CKT 1	192	192	0.769	107.9	180.9	GAVINS POINT - YANKON JCT 115KV CKT 1
13G	09G08_086N02	TO->FROM	KELLY - MADISONCO 230.00 230KV CKT 1	192	192	0.769	107.8	180.9	GEN652457 1-GARRISON
13G	09G08_086N02	TO->FROM	KELLY - MADISONCO 230.00 230KV CKT 1	192	192	0.769	107.8	181.1	GEN652458 2-GARRISON
13G	09G08_086N02	TO->FROM	KELLY - MADISONCO 230.00 230KV CKT 1	192	192	0.769	107.8	181.1	GEN652459 3-GARRISON
13G	09G08_086N02	TO->FROM	KELLY - MADISONCO 230.00 230KV CKT 1	192	192	0.775	107.8	181.1	FT THOMPSON - LAKE PLATT 230KV CKT 1
13G	09G08_086N02	TO->FROM	KELLY - MADISONCO 230.00 230KV CKT 1	192	192	0.769	107.8	181.2	ATCHSNT3 345.00 - COOPER 345KV CKT 1
13G	09G08_086N02	TO->FROM	KELLY - MADISONCO 230.00 230KV CKT 1	192	192	0.763	107.7	181.2	COLUMBUS - KELLY 115KV CKT 1
13G	09G08_086N02	TO->FROM	KELLY - MADISONCO 230.00 230KV CKT 1	192	192	0.763	107.7	181.3	KELLY (KELLY T1) 230/115/13.2KV TRANSFORMER CKT 1
13G	09G08_086N02	TO->FROM	KELLY - MADISONCO 230.00 230KV CKT 1	192	192	0.763	107.7	181.3	TRF-KELLY
13G	09G08_086N02	TO->FROM	KELLY - MADISONCO 230.00 230KV CKT 1	192	192	0.769	107.7	181.3	GEN652559 1-OAHE
13G	09G08_086N02	TO->FROM	KELLY - MADISONCO 230.00 230KV CKT 1	192	192	0.769	107.7	181.4	GEN652543 3-BIG BEND
13G	09G08_086N02	TO->FROM	KELLY - MADISONCO 230.00 230KV CKT 1	192	192	0.769	107.7	181.5	GEN652542 1-BIG BEND
13G	09G08_086N02	TO->FROM	KELLY - MADISONCO 230.00 230KV CKT 1	192	192	0.769	107.7	181.5	GEN652544 5-BIG BEND
13WP	00ALL	TO->FROM	KELLY - MADISONCO 230.00 230KV CKT 1	192	192	0.768	107.5	181.5	BASE CASE
13WP	00G08_086N02	TO->FROM	KELLY - MADISONCO 230.00 230KV CKT 1	192	192	0.768	107.5	181.9	BASE CASE
13G	09G08_086N02	TO->FROM	KELLY - MADISONCO 230.00 230KV CKT 1	192	192	0.769	107.4	181.9	ATCHSNT3 345.00 - BOONEVILLE 345KV CKT 1
13G	09G08_086N02	TO->FROM	KELLY - MADISONCO 230.00 230KV CKT 1	192	192	0.769	107.4	182	GEN659110 1-LELAND OLDS UNIT1
13G	09G08_086N02	TO->FROM	KELLY - MADISONCO 230.00 230KV CKT 1	192	192	0.768	107.3	182.1	LAKEFIELD 3 - RAUN 345KV CKT 1
13G	09ALL	TO->FROM	KELLY - MADISONCO 230.00 230KV CKT 1	192	192	0.769	107.1	182.3	GEN640418 1-ELKHORN RIDGE WIND
13G	09ALL	TO->FROM	KELLY - MADISONCO 230.00 230KV CKT 1	192	192	0.763	107.0	182.8	KELLY (KELLY T1) 230/115/13.2KV TRANSFORMER CKT 1
13G	09ALL	TO->FROM	KELLY - MADISONCO 230.00 230KV CKT 1	192	192	0.763	107.0	182.9	TRF-KELLY
13G	09ALL	TO->FROM	KELLY - MADISONCO 230.00 230KV CKT 1	192	192	0.763	107.0	182.9	COLUMBUS - KELLY 115KV CKT 1
13G	09ALL	TO->FROM	KELLY - MADISONCO 230.00 230KV CKT 1	192	192	0.774	107.1	182.9	GEN640418 1-ELKHORN RIDGE WIND
13G	09ALL	TO->FROM	KELLY - MADISONCO 230.00 230KV CKT 1	192	192	0.775	107.1	182.9	FT THOMPSON - LAKE PLATT 230KV CKT 1
13G	09G08_086N02	TO->FROM	KELLY - MADISONCO 230.00 230KV CKT 1	192	192	0.760	107.0	183	COLUMEAST - KELLY 230KV CKT 1
13G	09G08_086N02	TO->FROM	KELLY - MADISONCO 230.00 230KV CKT 1	192	192	0.760	107.0	183	COLUMEAST (COL.EAST T3) 230/115/13.8KV TRANSFORMER CKT 1
13G	09G08_086N02	TO->FROM	KELLY - MADISONCO 230.00 230KV CKT 1	192	192	0.770	107.0	183	AINSWORTH - AINSWORTH 115KV CKT 1
13G	09ALL	TO->FROM	KELLY - MADISONCO 230.00 230KV CKT 1	192	192	0.774	107.0	183.1	GEN659296 1-SDPRAIRWIND1W0.6900
13G	09ALL	TO->FROM	KELLY - MADISONCO 230.00 230KV CKT 1	192	192	0.769	106.9	183.2	GEN652457 1-GARRISON
13G	09ALL	TO->FROM	KELLY - MADISONCO 230.00 230KV CKT 1	192	192	0.769	106.9	183.3	GEN652458 2-GARRISON
13G	09ALL	TO->FROM	KELLY - MADISONCO 230.00 230KV CKT 1	192	192	0.769	106.9	183.3	GEN652459 3-GARRISON
13G	09ALL	TO->FROM	KELLY - MADISONCO 230.00 230KV CKT 1	192	192	0.774	106.9	183.3	GEN652457 1-GARRISON
13G	09ALL	TO->FROM	KELLY - MADISONCO 230.00 230KV CKT 1	192	192	0.774	106.9	183.4	GEN652458 2-GARRISON
13G	09ALL	TO->FROM	KELLY - MADISONCO 230.00 230KV CKT 1	192	192	0.774	106.9	183.4	GEN652459 3-GARRISON
13G	09G08_086N02	TO->FROM	KELLY - MADISONCO 230.00 230KV CKT 1	192	192	0.769	106.8	183.4	GEN652556 2-OAHE
13G	09ALL	TO->FROM	KELLY - MADISONCO 230.00 230KV CKT 1	192	192	0.769	106.8	183.6	GEN652543 3-BIG BEND
13G	09ALL	TO->FROM	KELLY - MADISONCO 230.00 230KV CKT 1	192	192	0.769	106.8	183.7	GEN652542 1-BIG BEND

Power Flow Analysis

Season	Dispatch Group	Flow	Overloaded Element	RATEA (MVA)	RATEB (MVA)	TDF	TC% LOADING	Max MW Available	Contingency
13G	09ALL	TO->FROM	KELLY - MADISONCO 230.00 230KV CKT 1	192	192	0.769	106.7	183.7	GEN652544 5-BIG BEND
13G	09ALL	TO->FROM	KELLY - MADISONCO 230.00 230KV CKT 1	192	192	0.769	106.7	183.8	GEN652559 1-OAHE
13G	09ALL	TO->FROM	KELLY - MADISONCO 230.00 230KV CKT 1	192	192	0.774	106.8	183.8	GEN652543 3-BIG BEND
13G	09ALL	TO->FROM	KELLY - MADISONCO 230.00 230KV CKT 1	192	192	0.774	106.8	183.8	GEN652542 1-BIG BEND
13G	09ALL	TO->FROM	KELLY - MADISONCO 230.00 230KV CKT 1	192	192	0.774	106.7	183.8	GEN652544 5-BIG BEND
13G	09G08_086N02	TO->FROM	KELLY - MADISONCO 230.00 230KV CKT 1	192	192	0.769	106.7	183.9	NUNDRWD - WAYSIDE 230KV CKT 1
13G	09ALL	TO->FROM	KELLY - MADISONCO 230.00 230KV CKT 1	192	192	0.774	106.7	183.9	GEN652559 1-OAHE
13G	09ALL	TO->FROM	KELLY - MADISONCO 230.00 230KV CKT 1	192	192	0.769	106.7	183.9	NELIGH - PETERSBRG.N7115.00 115KV CKT 1
13G	09G08_086N02	TO->FROM	KELLY - MADISONCO 230.00 230KV CKT 1	192	192	0.769	106.7	184	GEN652546 1-FT RANDAL
13G	09G08_086N02	TO->FROM	KELLY - MADISONCO 230.00 230KV CKT 1	192	192	0.769	106.7	184	STEGALL - WAYSIDE 230KV CKT 1
13G	09ALL	TO->FROM	KELLY - MADISONCO 230.00 230KV CKT 1	192	192	0.769	106.5	184	GEN659110 1-LELAND OLDS UNIT1
13G	09ALL	TO->FROM	KELLY - MADISONCO 230.00 230KV CKT 1	192	192	0.774	106.5	184.3	GEN659110 1-LELAND OLDS UNIT1
13G	09ALL	TO->FROM	KELLY - MADISONCO 230.00 230KV CKT 1	192	192	0.773	106.3	184.4	LAKEFIELD 3 - RAUN 345KV CKT 1
13G	09ALL	TO->FROM	KELLY - MADISONCO 230.00 230KV CKT 1	192	192	0.760	106.2	184.9	COLUMEAST - KELLY 230KV CKT 1
13G	09ALL	TO->FROM	KELLY - MADISONCO 230.00 230KV CKT 1	192	192	0.760	106.2	184.9	COLUMEAST (COL.EAST T3) 230/115/13.8KV TRANSFORMER CKT 1
13G	09G08_086N02	TO->FROM	KELLY - MADISONCO 230.00 230KV CKT 1	192	192	0.769	106.2	184.9	GEN652547 3-FT RANDAL
13G	09G08_086N02	TO->FROM	KELLY - MADISONCO 230.00 230KV CKT 1	192	192	0.769	106.2	185.2	GEN652548 5-FT RANDAL
13G	09G08_086N02	TO->FROM	KELLY - MADISONCO 230.00 230KV CKT 1	192	192	0.769	106.2	185.2	GEN652549 7-FT RANDAL
13G	09ALL	TO->FROM	KELLY - MADISONCO 230.00 230KV CKT 1	192	192	0.769	105.9	185.2	GEN652556 2-OAHE
13WP	00ALL	TO->FROM	KELLY - MADISONCO 230.00 230KV CKT 1	192	192	0.768	105.9	185.9	GEN652460 4-GARRISON
13WP	00G08_086N02	TO->FROM	KELLY - MADISONCO 230.00 230KV CKT 1	192	192	0.768	105.9	185.9	GEN652460 4-GARRISON
13WP	00ALL	TO->FROM	KELLY - MADISONCO 230.00 230KV CKT 1	192	192	0.768	105.9	185.9	GEN652461 5-GARRISON
13WP	00G08_086N02	TO->FROM	KELLY - MADISONCO 230.00 230KV CKT 1	192	192	0.768	105.9	185.9	GEN652461 5-GARRISON
13G	09ALL	TO->FROM	KELLY - MADISONCO 230.00 230KV CKT 1	192	192	0.774	105.9	185.9	GEN652556 2-OAHE
13WP	00ALL	TO->FROM	KELLY - MADISONCO 230.00 230KV CKT 1	192	192	0.768	105.8	185.9	GEN652457 1-GARRISON
13WP	00ALL	TO->FROM	KELLY - MADISONCO 230.00 230KV CKT 1	192	192	0.768	105.8	186	GEN652458 2-GARRISON
13WP	00ALL	TO->FROM	KELLY - MADISONCO 230.00 230KV CKT 1	192	192	0.768	105.8	186	GEN652459 3-GARRISON
13WP	00G08_086N02	TO->FROM	KELLY - MADISONCO 230.00 230KV CKT 1	192	192	0.768	105.8	186	GEN652457 1-GARRISON
13WP	00G08_086N02	TO->FROM	KELLY - MADISONCO 230.00 230KV CKT 1	192	192	0.768	105.8	186	GEN652458 2-GARRISON
13WP	00G08_086N02	TO->FROM	KELLY - MADISONCO 230.00 230KV CKT 1	192	192	0.768	105.8	186	GEN652459 3-GARRISON
13WP	00ALL	TO->FROM	KELLY - MADISONCO 230.00 230KV CKT 1	192	192	0.768	105.8	186	AINSWORTH - CALAMUS 115KV CKT 1
13WP	00G08_086N02	TO->FROM	KELLY - MADISONCO 230.00 230KV CKT 1	192	192	0.768	105.8	186.1	AINSWORTH - CALAMUS 115KV CKT 1
13WP	00ALL	TO->FROM	KELLY - MADISONCO 230.00 230KV CKT 1	192	192	0.768	105.8	186.1	LN-1090
13WP	00G08_086N02	TO->FROM	KELLY - MADISONCO 230.00 230KV CKT 1	192	192	0.768	105.8	186.1	LN-1090
13WP	00ALL	TO->FROM	KELLY - MADISONCO 230.00 230KV CKT 1	192	192	0.768	105.8	186.1	CALAMUS - THEDFORD 115KV CKT 1
13WP	00G08_086N02	TO->FROM	KELLY - MADISONCO 230.00 230KV CKT 1	192	192	0.768	105.8	186.2	CALAMUS - THEDFORD 115KV CKT 1
13WP	00ALL	TO->FROM	KELLY - MADISONCO 230.00 230KV CKT 1	192	192	0.768	105.7	186.2	FALLOW 3 345.00 - GRIMES 345KV CKT 1

Power Flow Analysis

Season	Dispatch Group	Flow	Overloaded Element	RATEA (MVA)	RATEB (MVA)	TDF	TC% LOADING	Max MW Available	Contingency
13WP	00G08_086N02	TO->FROM	KELLY - MADISONCO 230.00 230KV CKT 1	192	192	0.768	105.7	186.2	FALLOW 3 345.00 - GRIMES 345KV CKT 1
13G	09ALL	TO->FROM	KELLY - MADISONCO 230.00 230KV CKT 1	192	192	0.769	105.7	186.2	GEN652546 1-FT RANDAL
13WP	00ALL	TO->FROM	KELLY - MADISONCO 230.00 230KV CKT 1	192	192	0.768	105.7	186.3	GEN659296 1-SDPRAIRWND1W0.6900
13WP	00G08_086N02	TO->FROM	KELLY - MADISONCO 230.00 230KV CKT 1	192	192	0.768	105.7	186.3	GEN659296 1-SDPRAIRWND1W0.6900
13G	09ALL	TO->FROM	KELLY - MADISONCO 230.00 230KV CKT 1	192	192	0.769	105.7	186.3	STEGALL - WAYSIDE 230KV CKT 1
13G	09ALL	TO->FROM	KELLY - MADISONCO 230.00 230KV CKT 1	192	192	0.774	105.7	186.3	GEN652546 1-FT RANDAL
13WP	00ALL	TO->FROM	KELLY - MADISONCO 230.00 230KV CKT 1	192	192	0.769	105.7	186.4	RAUN - SUB 3451 FT CAL 345KV CKT 1
13WP	00G08_086N02	TO->FROM	KELLY - MADISONCO 230.00 230KV CKT 1	192	192	0.769	105.7	186.4	RAUN - SUB 3451 FT CAL 345KV CKT 1
13WP	00ALL	TO->FROM	KELLY - MADISONCO 230.00 230KV CKT 1	192	192	0.767	105.7	186.4	LAKEFIELD 3 - RAUN 345KV CKT 1
13WP	00G08_086N02	TO->FROM	KELLY - MADISONCO 230.00 230KV CKT 1	192	192	0.767	105.7	186.4	LAKEFIELD 3 - RAUN 345KV CKT 1
13WP	00ALL	TO->FROM	KELLY - MADISONCO 230.00 230KV CKT 1	192	192	0.767	105.7	186.4	HOSKINS (HOSKINS T2) 345/230/13.8KV TRANSFORMER CKT 1
13WP	00G08_086N02	TO->FROM	KELLY - MADISONCO 230.00 230KV CKT 1	192	192	0.767	105.7	186.4	HOSKINS (HOSKINS T2) 345/230/13.8KV TRANSFORMER CKT 1
13WP	00ALL	TO->FROM	KELLY - MADISONCO 230.00 230KV CKT 1	192	192	0.768	105.6	186.4	GAVINS POINT - YANKON JCT 115KV CKT 1
13WP	00G08_086N02	TO->FROM	KELLY - MADISONCO 230.00 230KV CKT 1	192	192	0.768	105.6	186.5	GAVINS POINT - YANKON JCT 115KV CKT 1
13WP	00ALL	TO->FROM	KELLY - MADISONCO 230.00 230KV CKT 1	192	192	0.766	105.5	186.5	COLUMBUS - SCHUYLER 115KV CKT 1
13WP	00G08_086N02	TO->FROM	KELLY - MADISONCO 230.00 230KV CKT 1	192	192	0.766	105.5	186.9	COLUMBUS - SCHUYLER 115KV CKT 1
13WP	00ALL	TO->FROM	KELLY - MADISONCO 230.00 230KV CKT 1	192	192	0.768	105.4	186.9	GEN652542 1-BIG BEND
13WP	00ALL	TO->FROM	KELLY - MADISONCO 230.00 230KV CKT 1	192	192	0.768	105.4	187	GEN652543 3-BIG BEND
13WP	00G08_086N02	TO->FROM	KELLY - MADISONCO 230.00 230KV CKT 1	192	192	0.768	105.4	187	GEN652542 1-BIG BEND
13WP	00G08_086N02	TO->FROM	KELLY - MADISONCO 230.00 230KV CKT 1	192	192	0.768	105.4	187	GEN652543 3-BIG BEND
13WP	00ALL	TO->FROM	KELLY - MADISONCO 230.00 230KV CKT 1	192	192	0.768	105.4	187	GEN652544 5-BIG BEND
13WP	00G08_086N02	TO->FROM	KELLY - MADISONCO 230.00 230KV CKT 1	192	192	0.768	105.4	187	GEN652544 5-BIG BEND
13WP	00ALL	TO->FROM	KELLY - MADISONCO 230.00 230KV CKT 1	192	192	0.768	105.4	187	MAXWELL - THEDFORD 115KV CKT 1
13WP	00G08_086N02	TO->FROM	KELLY - MADISONCO 230.00 230KV CKT 1	192	192	0.768	105.4	187.1	MAXWELL - THEDFORD 115KV CKT 1
13G	09ALL	TO->FROM	KELLY - MADISONCO 230.00 230KV CKT 1	192	192	0.769	105.3	187.4	GEN652547 3-FT RANDAL
13G	09ALL	TO->FROM	KELLY - MADISONCO 230.00 230KV CKT 1	192	192	0.769	105.3	187.5	GEN652548 5-FT RANDAL
13G	09ALL	TO->FROM	KELLY - MADISONCO 230.00 230KV CKT 1	192	192	0.769	105.3	187.5	GEN652549 7-FT RANDAL
13WP	00ALL	TO->FROM	KELLY - MADISONCO 230.00 230KV CKT 1	192	192	0.768	105.2	187.5	ATCHSNT3 345.00 - COOPER 345KV CKT 1
13WP	00G08_086N02	TO->FROM	KELLY - MADISONCO 230.00 230KV CKT 1	192	192	0.768	105.2	187.5	ATCHSNT3 345.00 - COOPER 345KV CKT 1
13G	09ALL	TO->FROM	KELLY - MADISONCO 230.00 230KV CKT 1	192	192	0.774	105.3	187.5	GEN652547 3-FT RANDAL
13G	09ALL	TO->FROM	KELLY - MADISONCO 230.00 230KV CKT 1	192	192	0.774	105.3	187.5	GEN652548 5-FT RANDAL
13G	09ALL	TO->FROM	KELLY - MADISONCO 230.00 230KV CKT 1	192	192	0.774	105.3	187.5	GEN652549 7-FT RANDAL
13WP	00ALL	TO->FROM	KELLY - MADISONCO 230.00 230KV CKT 1	192	192	0.761	105.1	187.5	COLUMBUS - KELLY 115KV CKT 1
13WP	00G08_086N02	TO->FROM	KELLY - MADISONCO 230.00 230KV CKT 1	192	192	0.761	105.1	187.7	COLUMBUS - KELLY 115KV CKT 1
13WP	00ALL	TO->FROM	KELLY - MADISONCO 230.00 230KV CKT 1	192	192	0.761	105.1	187.7	KELLY (KELLY T1) 230/115/13.2KV TRANSFORMER CKT 1
13WP	00ALL	TO->FROM	KELLY - MADISONCO 230.00 230KV CKT 1	192	192	0.761	105.1	187.8	TRF-KELLY
13WP	00G08_086N02	TO->FROM	KELLY - MADISONCO 230.00 230KV CKT 1	192	192	0.761	105.1	187.8	KELLY (KELLY T1) 230/115/13.2KV TRANSFORMER CKT 1

Power Flow Analysis

Season	Dispatch Group	Flow	Overloaded Element	RATEA (MVA)	RATEB (MVA)	TDF	TC% LOADING	Max MW Available	Contingency
13WP	00G08_086N02	TO->FROM	KELLY - MADISONCO 230.00 230KV CKT 1	192	192	0.761	105.1	187.8	TRF-KELLY
13G	09G08_086N02	TO->FROM	KELLY - MADISONCO 230.00 230KV CKT 1	192	192	0.725	104.8	187.8	KELLY - SHELL CREEK 230KV CKT 1
13G	09G08_086N02	TO->FROM	KELLY - MADISONCO 230.00 230KV CKT 1	192	192	0.725	104.8	187.9	SHELL CREEK (SHELLCREEKT1) 345/230/13.8KV TRANSFORMER CKT 1
13WP	00ALL	TO->FROM	KELLY - MADISONCO 230.00 230KV CKT 1	192	192	0.768	104.9	187.9	ATCHSNT3 345.00 - BOONEVILLE 345KV CKT 1
13WP	00G08_086N02	TO->FROM	KELLY - MADISONCO 230.00 230KV CKT 1	192	192	0.768	104.9	188.3	ATCHSNT3 345.00 - BOONEVILLE 345KV CKT 1
13WP	00ALL	TO->FROM	KELLY - MADISONCO 230.00 230KV CKT 1	192	192	0.768	104.9	188.3	GEN652546 1-FT RANDAL
13WP	00G08_086N02	TO->FROM	KELLY - MADISONCO 230.00 230KV CKT 1	192	192	0.768	104.9	188.4	GEN652546 1-FT RANDAL
13WP	00ALL	TO->FROM	KELLY - MADISONCO 230.00 230KV CKT 1	192	192	0.768	104.8	188.4	GEN652556 2-OAHE
13WP	00ALL	TO->FROM	KELLY - MADISONCO 230.00 230KV CKT 1	192	192	0.768	104.8	188.5	GEN652557 4-OAHE
13WP	00ALL	TO->FROM	KELLY - MADISONCO 230.00 230KV CKT 1	192	192	0.768	104.8	188.5	GEN652558 6-OAHE
13WP	00G08_086N02	TO->FROM	KELLY - MADISONCO 230.00 230KV CKT 1	192	192	0.768	104.8	188.5	GEN652556 2-OAHE
13WP	00G08_086N02	TO->FROM	KELLY - MADISONCO 230.00 230KV CKT 1	192	192	0.768	104.8	188.5	GEN652557 4-OAHE
13WP	00G08_086N02	TO->FROM	KELLY - MADISONCO 230.00 230KV CKT 1	192	192	0.768	104.8	188.5	GEN652558 6-OAHE
13WP	00ALL	TO->FROM	KELLY - MADISONCO 230.00 230KV CKT 1	192	192	0.768	104.7	188.5	AINSWORTH - AINSWORTH 115KV CKT 1
13WP	00G08_086N02	TO->FROM	KELLY - MADISONCO 230.00 230KV CKT 1	192	192	0.768	104.7	188.9	AINSWORTH - AINSWORTH 115KV CKT 1
13WP	00ALL	TO->FROM	KELLY - MADISONCO 230.00 230KV CKT 1	192	192	0.758	104.5	188.9	COLUMEAST - KELLY 230KV CKT 1
13WP	00G08_086N02	TO->FROM	KELLY - MADISONCO 230.00 230KV CKT 1	192	192	0.758	104.5	189.3	COLUMEAST - KELLY 230KV CKT 1
13WP	00ALL	TO->FROM	KELLY - MADISONCO 230.00 230KV CKT 1	192	192	0.758	104.5	189.3	COLUMEAST (COL.EAST T3) 230/115/13.8KV TRANSFORMER CKT 1
13WP	00G08_086N02	TO->FROM	KELLY - MADISONCO 230.00 230KV CKT 1	192	192	0.758	104.5	189.3	COLUMEAST (COL.EAST T3) 230/115/13.8KV TRANSFORMER CKT 1
13WP	00ALL	TO->FROM	KELLY - MADISONCO 230.00 230KV CKT 1	192	192	0.768	104.5	189.3	GEN652547 3-FT RANDAL
13WP	00ALL	TO->FROM	KELLY - MADISONCO 230.00 230KV CKT 1	192	192	0.768	104.5	189.4	GEN652548 5-FT RANDAL
13WP	00ALL	TO->FROM	KELLY - MADISONCO 230.00 230KV CKT 1	192	192	0.768	104.5	189.4	GEN652549 7-FT RANDAL
13WP	00G08_086N02	TO->FROM	KELLY - MADISONCO 230.00 230KV CKT 1	192	192	0.768	104.5	189.4	GEN652547 3-FT RANDAL
13WP	00G08_086N02	TO->FROM	KELLY - MADISONCO 230.00 230KV CKT 1	192	192	0.768	104.5	189.4	GEN652548 5-FT RANDAL
13WP	00G08_086N02	TO->FROM	KELLY - MADISONCO 230.00 230KV CKT 1	192	192	0.768	104.5	189.4	GEN652549 7-FT RANDAL
13WP	00ALL	TO->FROM	KELLY - MADISONCO 230.00 230KV CKT 1	192	192	0.768	104.3	189.4	NUNDRWD - WAYSIDE 230KV CKT 1
13WP	00G08_086N02	TO->FROM	KELLY - MADISONCO 230.00 230KV CKT 1	192	192	0.768	104.3	189.8	NUNDRWD - WAYSIDE 230KV CKT 1
13WP	00ALL	TO->FROM	KELLY - MADISONCO 230.00 230KV CKT 1	192	192	0.768	103.8	189.8	STEGALL - WAYSIDE 230KV CKT 1
13WP	00G08_086N02	TO->FROM	KELLY - MADISONCO 230.00 230KV CKT 1	192	192	0.768	103.8	191	STEGALL - WAYSIDE 230KV CKT 1
13G	09ALL	TO->FROM	KELLY - MADISONCO 230.00 230KV CKT 1	192	192	1.000	104.2	191.3	FT RANDAL - MADISONCO 230.00 230KV CKT 1
13G	09ALL	TO->FROM	KELLY - MADISONCO 230.00 230KV CKT 1	192	192	0.725	103.1	192.5	KELLY - SHELL CREEK 230KV CKT 1
13G	09G08_086N02	TO->FROM	KELLY - MADISONCO 230.00 230KV CKT 1	192	192	1.000	104.2	192.5	FT RANDAL - MADISONCO 230.00 230KV CKT 1
13G	09ALL	TO->FROM	KELLY - MADISONCO 230.00 230KV CKT 1	192	192	0.725	103.0	192.5	SHELL CREEK (SHELLCREEKT1) 345/230/13.8KV TRANSFORMER CKT 1
13SP	00ALL	TO->FROM	FT RANDAL - MADISONCO 230.00 230KV CKT 1	192	192	1.000	104.1	192.6	KELLY - MADISONCO 230.00 230KV CKT 1
13SP	00G08_086N02	TO->FROM	FT RANDAL - MADISONCO 230.00 230KV CKT 1	192	192	1.000	104.1	192.7	KELLY - MADISONCO 230.00 230KV CKT 1
13G	09G08_086N02	TO->FROM	KELLY - MADISONCO 230.00 230KV CKT 1	192	192	0.770	103.1	192.7	TRF-STEGALL
13G	09G08_086N02	TO->FROM	KELLY - MADISONCO 230.00 230KV CKT 1	192	192	0.770	103.1	192.8	NEB01WAPAB3

Power Flow Analysis

Season	Dispatch Group	Flow	Overloaded Element	RATEA (MVA)	RATEB (MVA)	TDF	TC% LOADING	Max MW Available	Contingency
13WP	00ALL	TO->FROM	KELLY - MADISONCO 230.00 230KV CKT 1	192	192	1.000	104.1	192.8	FT RANDAL - MADISONCO 230.00 230KV CKT 1
13WP	00G08_086N02	TO->FROM	KELLY - MADISONCO 230.00 230KV CKT 1	192	192	1.000	104.1	192.8	FT RANDAL - MADISONCO 230.00 230KV CKT 1
13SP	00ALL	TO->FROM	KELLY - MADISONCO 230.00 230KV CKT 1	192	192	1.000	104.0	192.8	FT RANDAL - MADISONCO 230.00 230KV CKT 1
13SP	00G08_086N02	TO->FROM	KELLY - MADISONCO 230.00 230KV CKT 1	192	192	1.000	104.0	192.9	FT RANDAL - MADISONCO 230.00 230KV CKT 1
13WP	00ALL	TO->FROM	KELLY - MADISONCO 230.00 230KV CKT 1	192	192	0.768	103.1	192.9	GEN659110 1-LELAND OLDS UNIT1
13WP	00G08_086N02	TO->FROM	KELLY - MADISONCO 230.00 230KV CKT 1	192	192	0.768	103.1	192.9	GEN659110 1-LELAND OLDS UNIT1
13WP	00ALL	TO->FROM	FT RANDAL - MADISONCO 230.00 230KV CKT 1	192	192	1.000	104.0	192.9	KELLY - MADISONCO 230.00 230KV CKT 1
13WP	00G08_086N02	TO->FROM	FT RANDAL - MADISONCO 230.00 230KV CKT 1	192	192	1.000	104.0	192.9	KELLY - MADISONCO 230.00 230KV CKT 1
13G	09G08_086N02	TO->FROM	FT RANDAL - MADISONCO 230.00 230KV CKT 1	192	192	1.000	104.0	192.9	KELLY - MADISONCO 230.00 230KV CKT 1
13G	09ALL	TO->FROM	FT RANDAL - MADISONCO 230.00 230KV CKT 1	192	192	1.000	104.0	193	KELLY - MADISONCO 230.00 230KV CKT 1
13WP	00ALL	TO->FROM	KELLY - MADISONCO 230.00 230KV CKT 1	192	192	0.774	102.6	193	FT RANDAL - LAKE PLATT 230KV CKT 1
13WP	00G08_086N02	TO->FROM	KELLY - MADISONCO 230.00 230KV CKT 1	192	192	0.774	102.6	194.1	FT RANDAL - LAKE PLATT 230KV CKT 1
13G	09G08_086N02	TO->FROM	KELLY - MADISONCO 230.00 230KV CKT 1	192	192	0.749	102.4	194.1	HOSKINS - SHELL CREEK 345KV CKT 1
13WP	00ALL	TO->FROM	KELLY - MADISONCO 230.00 230KV CKT 1	192	192	0.774	102.0	195.2	FT RANDAL - FT THOMPSON 230KV CKT 1
13WP	00G08_086N02	TO->FROM	KELLY - MADISONCO 230.00 230KV CKT 1	192	192	0.774	102.0	195.6	FT RANDAL - FT THOMPSON 230KV CKT 1
13WP	00ALL	TO->FROM	KELLY - MADISONCO 230.00 230KV CKT 1	192	192	0.724	101.8	195.6	KELLY - SHELL CREEK 230KV CKT 1
13WP	00G08_086N02	TO->FROM	KELLY - MADISONCO 230.00 230KV CKT 1	192	192	0.724	101.8	195.8	KELLY - SHELL CREEK 230KV CKT 1
13WP	00ALL	TO->FROM	KELLY - MADISONCO 230.00 230KV CKT 1	192	192	0.724	101.8	195.8	SHELL CREEK (SHELLCREEKT1) 345/230/13.8KV TRANSFORMER CKT 1
13WP	00G08_086N02	TO->FROM	KELLY - MADISONCO 230.00 230KV CKT 1	192	192	0.724	101.8	195.8	SHELL CREEK (SHELLCREEKT1) 345/230/13.8KV TRANSFORMER CKT 1
13WP	00ALL	TO->FROM	KELLY - MADISONCO 230.00 230KV CKT 1	192	192	0.774	101.8	195.8	FT THOMPSON - LAKE PLATT 230KV CKT 1
13WP	00G08_086N02	TO->FROM	KELLY - MADISONCO 230.00 230KV CKT 1	192	192	0.774	101.8	196.1	FT THOMPSON - LAKE PLATT 230KV CKT 1
13G	09ALL	TO->FROM	KELLY - MADISONCO 230.00 230KV CKT 1	192	192	0.769	101.2	196.1	GEN659111 2-LELAND OLDS UNIT2
13G	09ALL	TO->FROM	KELLY - MADISONCO 230.00 230KV CKT 1	192	192	0.774	101.2	197.6	GEN659111 2-LELAND OLDS UNIT2
13G	09ALL	TO->FROM	KELLY - MADISONCO 230.00 230KV CKT 1	192	192	0.755	101.0	197.6	HOSKINS - SHELL CREEK 345KV CKT 1
13WP	00ALL	TO->FROM	KELLY - MADISONCO 230.00 230KV CKT 1	192	192	0.768	100.2	198.1	RAUN - SIOUX CITY 345KV CKT 1
13WP	00G08_086N02	TO->FROM	KELLY - MADISONCO 230.00 230KV CKT 1	192	192	0.768	100.2	200.1	RAUN - SIOUX CITY 345KV CKT 1



## Stability Analysis

Transient stability analysis is used to determine if the transmission system can maintain angular stability and ensure bus voltages stay within planning criteria bandwidth during and after a disturbance while considering the addition of a generator interconnection request.

### Model Preparation

Transient stability analysis was performed using modified versions of the 2012 series of Model Development Working Group (MDWG) dynamic study models including the 2014 (summer and winter) seasonal models. The cases are then adapted to resemble the power flow study cases with regards to prior queued generation requests and topology. Finally the prior queued and study generation dispatched into the SPP footprint. Initial simulations are then carried out for a no-disturbance run of twenty (20) seconds to verify the numerical stability of the model.

### Disturbances

The twenty-five (25) contingencies were identified for the Limited Operation scenario for use in this study. These faults are listed within *Table 5*. These contingencies included three-phase faults and single-phase line faults at locations defined by SPP. Single-phase line faults were simulated by applying fault impedance to the positive sequence network at the fault location to represent the effect of the negative and zero sequence networks on the positive sequence network. The fault impedance was computed to give a positive sequence voltage at the specified fault location of approximately 60% of pre-fault voltage. This method is in agreement with SPP current practice.

With exception to transformers, the typical sequence of events for a three-phase and single-phase fault is as follows:

1. apply fault at particular location
2. continue fault for five (5) cycles, clear the fault by tripping the faulted facility
3. after an additional twenty (20) cycles, re-close the previous facility back into the fault
4. continue fault for five (5) additional cycles
5. trip the faulted facility and remove the fault

Transformer faults are typically only performed for three-phase faults, unless otherwise noted. Additionally the sequence of events for a transformer is to 1) apply a three-phase fault for five (5) cycles and 2) clear the fault by tripping the affected transformer facility. Unless otherwise noted there will be no re-closing into a transformer fault.

*Table 5: Contingencies Evaluated for Limited Operation*

Contingency Number and Name		Description
1	FLT_01_MADISONCO_COLUMBUS_230kV_3PH	3-Phase fault on the Madison Co. (GEN-2008-086N02 POI) – Kelly (Columbus) 230kV near the Madison Co. 230kV bus.
2	FLT_02_MADISONCO_COLUMBUS_230kV_1PH	Single-phase fault similar to previous fault.
3	FLT_03_MADISONCO_FTRANDLE_230kV_3PH	3-Phase fault on the WAPA Fort Randall – Madison Co. (GEN-2008-086N02 POI) 230kV near the Madison Co. 230kV bus.
4	FLT_04_MADISONCO_FTRANDLE_230kV_1PH	Single-phase fault similar to previous fault.

Contingency Number and Name		Description
5	FLT_05_FTRANDLE_FTTHOMPSON_230kV_3PH	3-Phase fault on the WAPA Fort Randall – WAPA Fort Thompson 230kV near the Fort Randall 230kV bus.
6	FLT_06_FTRANDLE_FTTHOMPSON_230kV_1PH	Single-phase fault similar to previous fault.
7	FLT_07_FTRANDLE_FTRANDLE7_230_115kV_3PH	3-Phase fault on the WAPA Fort Randall 230/115kV Transformer near the Fort Randall 230kV bus.
8	FLT_08_FTRANDLE_FTRANDLE7_230_115kV_3PH	3-Phase fault on the WAPA Fort Randall 230/115kV Transformer near the Fort Randall 115kV bus.
9	FLT_09_FTRANDLE_LKPLATTE_230kV_3PH	3-Phase fault on the WAPA Fort Randall – WAPA Lake Platte 230kV near the Fort Randall 230kV bus.
10	FLT_10_FTRANDLE_LKPLATTE_230kV_1PH	Single-phase fault similar to previous fault.
11	FLT_11_FTRANDLE_UTICAJCN_230kV_3PH	3-Phase fault on the WAPA Fort Randall – WAPA Utica Junction 230kV near the Fort Randall 230kV bus.
12	FLT_12_FTRANDLE_UTICAJCN_230kV_1PH	Single-phase fault similar to previous fault.
13	FLT_13_FTRANDLE_SIOUXCTY_230kV_3PH	3-Phase fault on the WAPA Fort Randall – WAPA Sioux City 230kV near the Fort Randall 230kV bus.
14	FLT_14_FTRANDLE_SIOUXCTY_230kV_1PH	Single-phase fault similar to previous fault.
15	FLT_15_COLUMBUS_ECOLUMBUS_230kV_3PH	3-Phase fault on the Columbus – East Columbus 230kV near the Columbus 230kV bus.
16	FLT_16_COLUMBUS_ECOLUMBUS_230kV_1PH	Single-phase fault similar to previous fault.
17	FLT_17_COLUMBUS_COLUMBUSW_230kV_3PH	3-Phase fault on the Columbus – Columbus West 230kV near the Columbus 230kV bus.
18	FLT_18_COLUMBUS_COLUMBUSW_230kV_1PH	Single-phase fault similar to previous fault.
19	FLT_19_COLUMBUS_SHELLCRK_230kV_3PH	3-Phase fault on the Columbus – Shell Creek 230kV near the Columbus 230kV bus.
20	FLT_20_COLUMBUS_SHELLCRK_230kV_1PH	Single-phase fault similar to previous fault.
21	FLT_21_COLUMBUS_KELLY_230_115kV_3PH	3-Phase fault on the Kelly (Columbus) 230/115kV Transformer near the Kelly (Columbus) 230kV bus.
22	FLT_22_FTTHOMPSON_GRNDISLAND_345kV_3PH	3-Phase fault on the WAPA Fort Thompson – Grand Island 345kV near the Fort Thompson 345kV bus.
23	FLT_23_FTTHOMPSON_GRNDISLAND_345kV_1PH	Single-phase fault similar to previous fault.
24	FLT_24_HOSKINS_RAUN_345kV_3PH	3-Phase fault on the Hoskins – MEC Raun 345kV near the Hoskins 345kV bus.
25	FLT_25_HOSKINS_RAUN_345kV_1PH	Single-phase fault similar to previous fault.

### Power Factor Analysis

No additional power factor analysis was performed for this study. Prior power factor requirements determined during the DISIS-2009-001 are still considered valid.

### Results

Results of the stability analysis are summarized in Table 6. These results are valid for GEN-2008-086N02 interconnecting with a generation amount up to 200.6 MW. The results indicate that the transmission system remains stable for all contingencies studied.

Table 6: Fault Analysis Results for Limited Operation

Contingency Number and Name		2014SP	2014WP
1	FLT_01_MADISONCO_COLUMBUS_230kV_3PH	Stable	Stable
2	FLT_02_MADISONCO_COLUMBUS_230kV_1PH	Stable	Stable
3	FLT_03_MADISONCO_FTRANDLE_230kV_3PH	Stable	Stable
4	FLT_04_MADISONCO_FTRANDLE_230kV_1PH	Stable	Stable
5	FLT_05_FTRANDLE_FTTHOMPSON_230kV_3PH	Stable	Stable
6	FLT_06_FTRANDLE_FTTHOMPSON_230kV_1PH	Stable	Stable
7	FLT_07_FTRANDLE_FTRANDLE7_230_115kV_3PH	Stable	Stable
8	FLT_08_FTRANDLE_FTRANDLE7_230_115kV_3PH	Stable	Stable

	Contingency Number and Name	2014SP	2014WP
9	FLT_09_FTRANDLE_LKPLATTE_230kV_3PH	Stable	Stable
10	FLT_10_FTRANDLE_LKPLATTE_230kV_1PH	Stable	Stable
11	FLT_11_FTRANDLE_UTICAJCN_230kV_3PH	Stable	Stable
12	FLT_12_FTRANDLE_UTICAJCN_230kV_1PH	Stable	Stable
13	FLT_13_FTRANDLE_SIOUXCTY_230kV_3PH	Stable	Stable
14	FLT_14_FTRANDLE_SIOUXCTY_230kV_1PH	Stable	Stable
15	FLT_15_COLUMBUS_ECOLUMBUS_230kV_3PH	Stable	Stable
16	FLT_16_COLUMBUS_ECOLUMBUS_230kV_1PH	Stable	Stable
17	FLT_17_COLUMBUS_COLUMBUSW_230kV_3PH	Stable	Stable
18	FLT_18_COLUMBUS_COLUMBUSW_230kV_1PH	Stable	Stable
19	FLT_19_COLUMBUS_SHELLCRK_230kV_3PH	Stable	Stable
20	FLT_20_COLUMBUS_SHELLCRK_230kV_1PH	Stable	Stable
21	FLT_21_COLUMBUS_KELLY_230_115kV_3PH	Stable	Stable
22	FLT_22_FTTHOMPSON_GRNDISLAND_345kV_3PH	Stable	Stable
23	FLT_23_FTTHOMPSON_GRNDISLAND_345kV_1PH	Stable	Stable
24	FLT_24_HOSKINS_RAUN_345kV_3PH	Stable	Stable
25	FLT_25_HOSKINS_RAUN_345kV_1PH	Stable	Stable

## FERC LVRT Compliance

FERC Order #661A places specific requirements on wind farms through its Low Voltage Ride Through (LVRT) provisions. For Interconnection Agreements signed after December 31, 2006, wind farms shall stay on line for faults at the POI that draw the voltage down at the POI to 0.0 pu.

Fault contingencies were developed to verify that wind farms remain on line when the POI voltage is drawn down to 0.0 pu. These contingencies are shown in *Table 7*.

*Table 7: LVRT Contingencies*

	Contingency Number and Name	Description
1	FLT_05_FTRANDLE_FTTHOMPSON_230kV_3PH	3-Phase fault on the WAPA Fort Randall – WAPA Fort Thompson 230kV near the Fort Randall 230kV bus.
2	FLT_06_FTRANDLE_FTTHOMPSON_230kV_1PH	Single-phase fault similar to previous fault.
3	FLT_07_FTRANDLE_FTRANDLE7_230_115kV_3PH	3-Phase fault on the WAPA Fort Randall 230/115kV Transformer near the Fort Randall 230kV bus.
4	FLT_08_FTRANDLE_FTRANDLE7_230_115kV_3PH	3-Phase fault on the WAPA Fort Randall 230/115kV Transformer near the Fort Randall 115kV bus.

The required prior queued project wind farms remained online for the fault contingencies described in this section as well as the fault contingencies described in the Disturbances section of this report. GEN-2008-086N02 is found to be in compliance with FERC Order #661A.

---

## Conclusion

---

<OMITTED TEXT> (Interconnection Customer, GEN-2008-086N02) has requested a Limited Operation System Impact Study under the Southwest Power Pool Open Access Transmission Tariff for 200.6 MW of wind generation to be interconnected as an Energy Resource into a transmission tie facility between the Western Area Power Administration (WAPA) and the Nebraska Public Power District (NPPD). The point of interconnection facilities will be constructed and owned by NPPD and located in Madison County, Nebraska. GEN-2008-086N02, under GIA Section 5.9, has requested this Limited Operation Interconnection Study (LOIS) to determine the impacts of interconnecting to the transmission system before all required Network Upgrades identified in the DISIS-2009-001 report can be placed into service.

Power flow analysis from this LOIS has determined that the GEN-2008-086N02 request can interconnect prior to the completion of the required Network Upgrades, listed within Table 2 of this report. There is 98 MW of Limited Operation Interconnection Service available for the period of January 1, 2014 until the completion of the WAPA Fort Randall – Kelly (Columbus) 230kV upgrades which will allow the line to be re-rated to 320MVA. This line is scheduled for completion in October, 2014. After this network upgrade is completed, limited operation may be available until such time that higher queued projects listed in Table 3 come into service.

Transient stability analysis indicates that the transmission system will remain stable for the contingencies listed within Table 5 with the addition of GEN-2008-086N02 generation. Additionally, GEN-2008-086N02 was found to be in compliance with FERC Order #661A when studied as listed within this report.

Any changes to these assumptions, for example, one or more of the previously queued requests not included within this study execute an interconnection agreement and commencing commercial operation, may require a re-study of this LOIS at the expense of the Customer.

Nothing in this System Impact Study constitutes a request for transmission service or confers upon the Interconnection Customer any right to receive transmission service.