



**Feasibility Study
For
Generation Interconnection
Request
GEN-2007-052**

SPP Tariff Studies
(#GEN-2007-052)

May, 2008

Executive Summary

<OMITTED TEXT> (Customer) has requested a Feasibility Study for the purpose of interconnecting 150 MW of generation within the control area of Western Farmers Electric Cooperative (WFEC) located in Caddo County, Oklahoma. The proposed interconnection point is at the existing Anadarko 138 kV station, owned by WFEC. The proposed in-service date is May 1, 2009.

Power flow analysis has indicated that for the powerflow cases studied, it is possible to interconnect the 150 MW of generation with transmission system reinforcements within the local transmission system. The requirement to interconnect the 150 MW of generation consists of adding two new 138 kV circuit-breakers and terminal at the existing Anadarko 138 kV station.

The total minimum cost for building the required facilities for this 150 MW of generation is \$750,000. These costs are shown in Tables 1 and 2. Network constraints in the American Electric Power West (AEPW), Oklahoma Gas and Electric (OKGE), Southwestern Public Service Company (SPS), and WFEC transmission systems that were identified are shown in Table 3. These Network constraints will have to be verified with a Transmission Service Request (TSR) and associated studies. Network Constraints are in the local area of the new generation when this generation is sunk throughout the SPP footprint for the Energy Resource (ER) Interconnection request. With a defined source and sink in a Transmission Service Request, this list of Network Constraints will be refined and expanded to account for all Network Upgrade requirements.

In Table 4, a value of Available Transfer Capability (ATC) associated with each overloaded facility is included. These values may be used by the Customer for future analyses including the determination of lower generation capacity levels that may be installed. When transmission service associated with this interconnection is evaluated, the loading of the facilities listed in this table may be greater due to higher priority reservations. If the loading of a facility is higher, the level of ATC will be lower.

There are several other proposed generation additions in the general area of the Customer's facility. It was assumed in this preliminary analysis that not all of these other projects within the AEPW, OKGE, and WFEC control areas will be in service. Those previously queued projects that have advanced to nearly complete phases were included in this Feasibility Study. In the event that another request for a generation interconnection with a higher priority withdraws, then this request may have to be re-evaluated to determine the local Network Constraints.

The required interconnection costs listed in Tables 1 and 2 and other upgrades associated with Network Constraints do not include all costs associated with the deliverability of the energy to final customers. These costs are determined by separate studies if the Customer submits a Transmission Service Request through Southwest Power Pool's OASIS.

Contents

Introduction	4
Interconnection Facilities	4
Interconnection Estimated Costs	6
Powerflow Analysis	7
Powerflow Analysis Methodology	8
Powerflow Results.....	9
Conclusion	11
Appendix A: Point of Interconnection Area Map.....	12

Tables

Table 1: Direct Assignment Facilities	6
Table 2: Required Interconnection Network Upgrade Facilities.....	6
Table 3: Network Constraints.....	9
Table 4: Contingency Analysis	10

Figures

Figure 1: Proposed Method of Interconnection	5
Figure 2: Point of Interconnection Area Map	12

Introduction

<OMITTED TEXT> (Customer) has requested a Feasibility Study for the purpose of interconnecting 150 MW of generation within the control area of Western Farmers Electric Cooperative (WFEC) located in Caddo County, Oklahoma. The proposed interconnection point is at the existing Anadarko 138 kV station, owned by WFEC. The proposed in-service date is May 1, 2009.

Interconnection Facilities

The primary objective of this study is to identify the system problems associated with connecting the generation to the area transmission system. The Feasibility and other subsequent Interconnection Studies are designed to identify attachment facilities, Network Upgrades and other Direct Assignment Facilities needed to accept power into the grid at the interconnection receipt point.

The requirement to interconnect the 150 MW of generation consists of adding two new 138 kV circuit-breakers and terminal at the existing Anadarko 138 kV station. A preliminary one-line drawing of the interconnection and direct assigned facilities are shown in Figure 1.

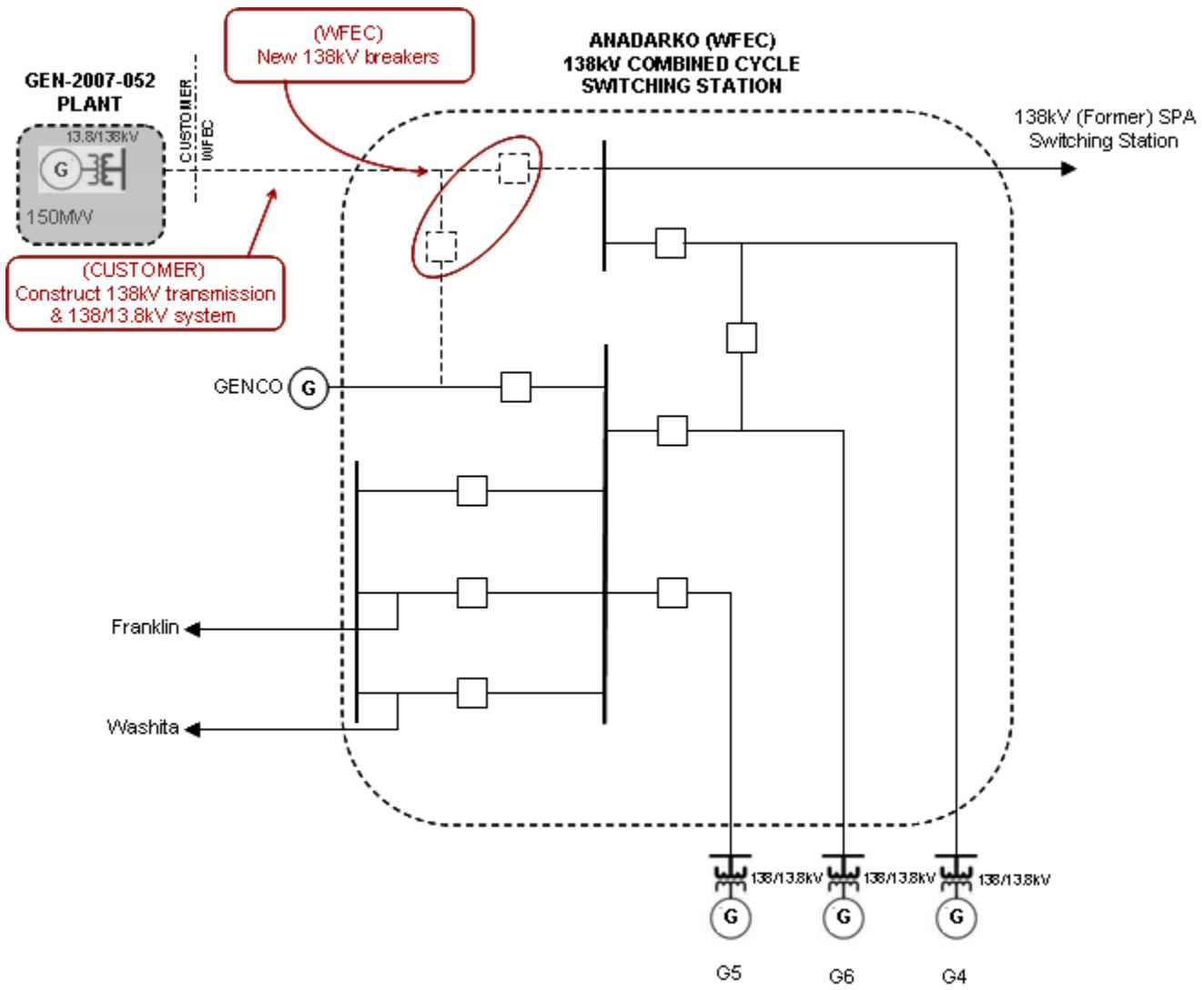

Figure 1: Proposed Method of Interconnection
 (Final design to be determined)

Interconnection Estimated Costs

The minimum cost for adding two new 138 kV circuit-breakers and terminal serving the GEN-2007-052 facilities is estimated at \$750,000. These costs are listed in Tables 1 and 2. These estimates will be refined during the development of the System Impact Study based on the final designs. This cost does not include the Customer's facilities up to the point of interconnection, all of which should be determined by the Customer. The Customer is responsible for these 138 kV – 13.8 kV facilities up to the point of interconnection. Other network constraints in the American Electric Power West (AEPW), Oklahoma Gas and Electric (OKGE), Southwestern Public Service Company (SPS), and WFEC transmission systems that were identified are shown in Table 3.

The costs of interconnecting the facility to the WFEC transmission system are listed in Table 1 & 2. **These costs do not include any cost that might be associated with short circuit study results or dynamic stability study results.** These costs will be determined when and if a System Impact Study is conducted.

Table 1: Direct Assignment Facilities

FACILITY	ESTIMATED COST (2008 DOLLARS)
CUSTOMER – 138/13.8 kV substation facilities.	*
CUSTOMER – 138 kV line between Customer substation and the Anadarko 138 kV station.	*
CUSTOMER – Possible reactive compensation to be determined during Impact Study.	*
CUSTOMER – Right-of-Way for all Customer facilities.	
WFEC – Build two 138 kV circuit-breakers and termination of line serving GEN-2007-052.	\$750,000
TOTAL	750,000

* Estimates of cost to be determined.

Table 2: Required Interconnection Network Upgrade Facilities

FACILITY	ESTIMATED COST (2007 DOLLARS)
None identified at this time.	*
TOTAL	*

* Estimates of cost to be determined.

Powerflow Analysis

A powerflow analysis was conducted for the facility using modified versions of the 2009 and 2012 summer and winter peak models and the 2017 summer peak model. The output of the Customer's facility was offset in each model by a reduction in output of existing online SPP generation. This method allows the request to be studied as an Energy Resource (ER) Interconnection request. The proposed in-service date of the generation is May 1, 2009. The available seasonal models used were through the 2017 Summer Peak of which is the end of the current SPP planning horizon.

Following current practice, this analysis was conducted assuming that previous queued requests in the immediate area of this interconnect request were in service. The analysis of the Customer's project indicates that, given the requested generation level of 150 MW and location, additional criteria violations will occur on the existing AEPW, OKGE, SPS, and WFEC transmission systems under steady state and contingency conditions in the peak seasons. Table 3 lists these overloaded facilities.

In Table 4, a value of Available Transfer Capability (ATC) associated with each overloaded facility is included. These values may be used by the Customer to determine lower generation capacity levels that may be installed. When transmission service associated with this interconnection is evaluated, the loading of the facilities listed in this table may be greater due to higher priority reservations. When a facility is overloaded for more than one contingency, only the highest loading on the facility for each season is included in the table.

There are several other proposed generation additions in the general area of the Customer's facility. Some of the local projects that were previously queued were assumed to be in service in this Feasibility Study. Not all local projects that were previously queued and have advanced to nearly complete phases were included in this Feasibility Study.

Powerflow Analysis Methodology

The Southwest Power Pool (SPP) criteria states that: “The transmission system of the SPP region shall be planned and constructed so that the contingencies as set forth in the Criteria will meet the applicable NERC Planning Standards for System Adequacy and Security – Transmission System Table I hereafter referred to as NERC Table I) and its applicable standards and measurements”.

Using the created models and the ACCC function of PSS/E, single contingencies in portions or all of the modeled control areas of Sunflower Electric Power Corporation (SUNC), Missouri Public Service (MIPU), Westar Energy (WERE), Kansas City Power & Light (KCPL), West Plains (WEPL), Midwest Energy (MIDW), Oklahoma Gas and Electric (OKGE), American Electric Power West (AEPW), Grand River Dam Authority (GRDA), Southwestern Public Service Company (SPS), Western Farmers Electric Cooperative (WFEC) and other control areas were applied and the resulting scenarios analyzed. This satisfies the ‘more probable’ contingency testing criteria mandated by NERC and the SPP criteria.

Powerflow Results

Table 3: Network Constraints

AREA	OVERLOADED ELEMENT
AEPW	FLETCHER TAP - LAWTON EASTSIDE 138KV CKT 1
AEPW	NORGE ROAD - SOUTHWESTERN STATION 138KV CKT 1
AEPW/SPS	2006-02T 230.00 - GRAPEVINE INTERCHANGE 230KV CKT 1
AEPW/WFEC	SOUTHWESTERN STATION - WASHITA 138KV CKT 1
OKGE	CIMARRON - HAYMAKER 138KV CKT 1
OKGE	DIVISION AVE - HAYMAKER 138KV CKT 1
WFEC	ANADARKO - BLANCHARD 69KV CKT 1
WFEC	ANADARKO - CORN TAP 138KV CKT 1
WFEC	ANADARKO 138/69KV TRANSFORMER CKT 1
WFEC	COMANCHE 138/69KV TRANSFORMER CKT 1
WFEC	FLETCHER - GEORGIA 138KV CKT 1
WFEC	FLETCHER - MARLOW JCT 69KV CKT 1
WFEC	FLETCHER - MEDICINE PARK JCT 69KV CKT 1
AEPW	American Electric Power West
OKGE	Oklahoma Gas and Electric
SPS	Southwest Public Service Company
WFEC	Western Farmers

Table 4: Contingency Analysis

SEASON	OVERLOADED ELEMENT	RATING (MVA)	LOADING (%)	ATC (MW)	CONTINGENCY
09SP	FLETCHER TAP - LAWTON EASTSIDE 138KV CKT 1	143	124	0	ELGIN JUNCTION - SOUTHWESTERN STATION 138KV CKT 1
09SP	ANADARKO - CORN TAP 138KV CKT 1	118	121	0	BASE CASE
09SP	NORGE ROAD - SOUTHWESTERN STATION 138KV CKT 1	143	110	0	SOUTHWESTERN STATION - VERDEN 138KV CKT 1
09SP	ANADARKO - CORN TAP 138KV CKT 1	154	115	2	SOUTHWESTERN STATION - VERDEN 138KV CKT 1
09SP	ANADARKO 138/69KV TRANSFORMER CKT 1	112	112	11	ANADARKO - GEORGIA 138KV CKT 1
09SP	FLETCHER - GEORGIA 138KV CKT 1	130	106	56	BASE CASE
09SP	COMANCHE 138/69KV TRANSFORMER CKT 1	56	102	121	COMANCHE - LOCO 138KV CKT 1
09WP	ANADARKO 138/69KV TRANSFORMER CKT 1	112	112	22	ANADARKO - GEORGIA 138KV CKT 1
09WP	DIVISION AVE - HAYMAKER 138KV CKT 1	308	102	32	CIMARRON - CZECH HALL 138KV CKT 1
12SP	FLETCHER - MEDICINE PARK JCT 69KV CKT 1	61	119	0	ANADARKO - GRGIAJT4 138.00 138KV CKT 1
12SP	FLETCHER - MARLOW JCT 69KV CKT 1	61	115	0	EMPIRE - FLETCHER 138KV CKT 1
12SP	CIMARRON - HAYMAKER 138KV CKT 1	308	112	0	CIMARRON - CZECH HALL 138KV CKT 1
12SP	DIVISION AVE - HAYMAKER 138KV CKT 1	308	108	0	CIMARRON - CZECH HALL 138KV CKT 1
12SP	ANADARKO - CORN TAP 138KV CKT 1	118	112	62	BASE CASE
12SP	NORGE ROAD - SOUTHWESTERN STATION 138KV CKT 1	143	103	77	SOUTHWESTERN STATION - VERDEN 138KV CKT 1
12SP	ANADARKO - CORN TAP 138KV CKT 1	154	106	94	SOUTHWESTERN STATION - VERDEN 138KV CKT 1
12WP	DIVISION AVE - HAYMAKER 138KV CKT 1	308	110	0	CIMARRON - CZECH HALL 138KV CKT 1
12WP	SOUTHWESTERN STATION - WASHITA 138KV CKT 1	196	106	45	BASE CASE
12WP	FLETCHER - MARLOW JCT 69KV CKT 1	61	102	123	EMPIRE - FLETCHER 138KV CKT 1
12WP	SOUTHWESTERN STATION - WASHITA 138KV CKT 1	260	101	129	2007-32T 138.00 - CLINTON JUNCTION 138KV CKT 1
12WP	ANADARKO - BLANCHARD 69KV CKT 1	34	101	134	2006-02T 230.00 - GRAPEVINE INTERCHANGE 230KV CKT 1
12WP	ANADARKO - CORN TAP 138KV CKT 1	118	100	147	BASE CASE
17SP	FLETCHER - MEDICINE PARK JCT 69KV CKT 1	61	118	0	ANADARKO - GEORGIA JUNCTION TAP 138KV CKT 1
17SP	FLETCHER - MARLOW JCT 69KV CKT 1	61	114	0	EMPIRE - FLETCHER 138KV CKT 1
17SP	CIMARRON - HAYMAKER 138KV CKT 1	308	111	0	CIMARRON - CZECH HALL 138KV CKT 1
17SP	2006-02T 230.00 - GRAPEVINE INTERCHANGE 230KV CKT 1	351	109	0	SPP-SWPS-01: TUCO INTERCHANGE 345/230/13.2KV TRANSFORMER CKT 1, TUCO INTERCHANGE - OKLAUNION 345KV CKT 1
17SP	DIVISION AVE - HAYMAKER 138KV CKT 1	308	106	0	CIMARRON - CZECH HALL 138KV CKT 1
17SP	ANADARKO - CORN TAP 138KV CKT 1	118	108	88	BASE CASE
17SP	ANADARKO - CORN TAP 138KV CKT 1	154	103	121	SOUTHWESTERN STATION - VERDEN 138KV CKT 1
17SP	NORGE ROAD - SOUTHWESTERN STATION 138KV CKT 1	143	101	125	SOUTHWESTERN STATION - VERDEN 138KV CKT 1

Note: When transmission service associated with this interconnection is evaluated, the loading of the facilities listed in this Table may be greater due to higher priority reservations. If the loading of a facility is higher, the level of ATC will be lower.

Conclusion

The minimum cost of interconnecting the Customer's interconnection request is estimated at \$750,000 for Direct Assignment Facilities and Network Upgrades. At this time, the cost estimates for other Direct Assignment facilities including those in Tables 1 and 2 have not been defined by the Customer. As stated earlier, some but not all of the local projects that were previously queued are assumed to be in service in this Feasibility Study. These costs exclude upgrades of other transmission facilities that were listed in Table 3 of which are Network Constraints.

In Table 4, a value of Available Transfer Capability (ATC) associated with each overloaded facility is included. These values may be used by the Customer to determine lower generation capacity levels that may be installed. When transmission service associated with this interconnection is evaluated, the loading of the facilities listed in this table may be greater due to higher priority reservations. When a facility is overloaded for more than one contingency, only the highest loading on the facility for each season is included in the table.

These interconnection costs do not include any cost that may be associated with short circuit or transient stability analysis. These studies will be performed if the Customer signs a System Impact Study Agreement. At the time of the System Impact Study, a better determination of the interconnection facilities may be available.

The required interconnection costs listed in Tables 1 and 2 and other upgrades associated with Network Constraints do not include all costs associated with the deliverability of the energy to final customers. These costs are determined by separate studies if the Customer submits a Transmission Service Request through Southwest Power Pool's OASIS.

Appendix A: Point of Interconnection Area Map

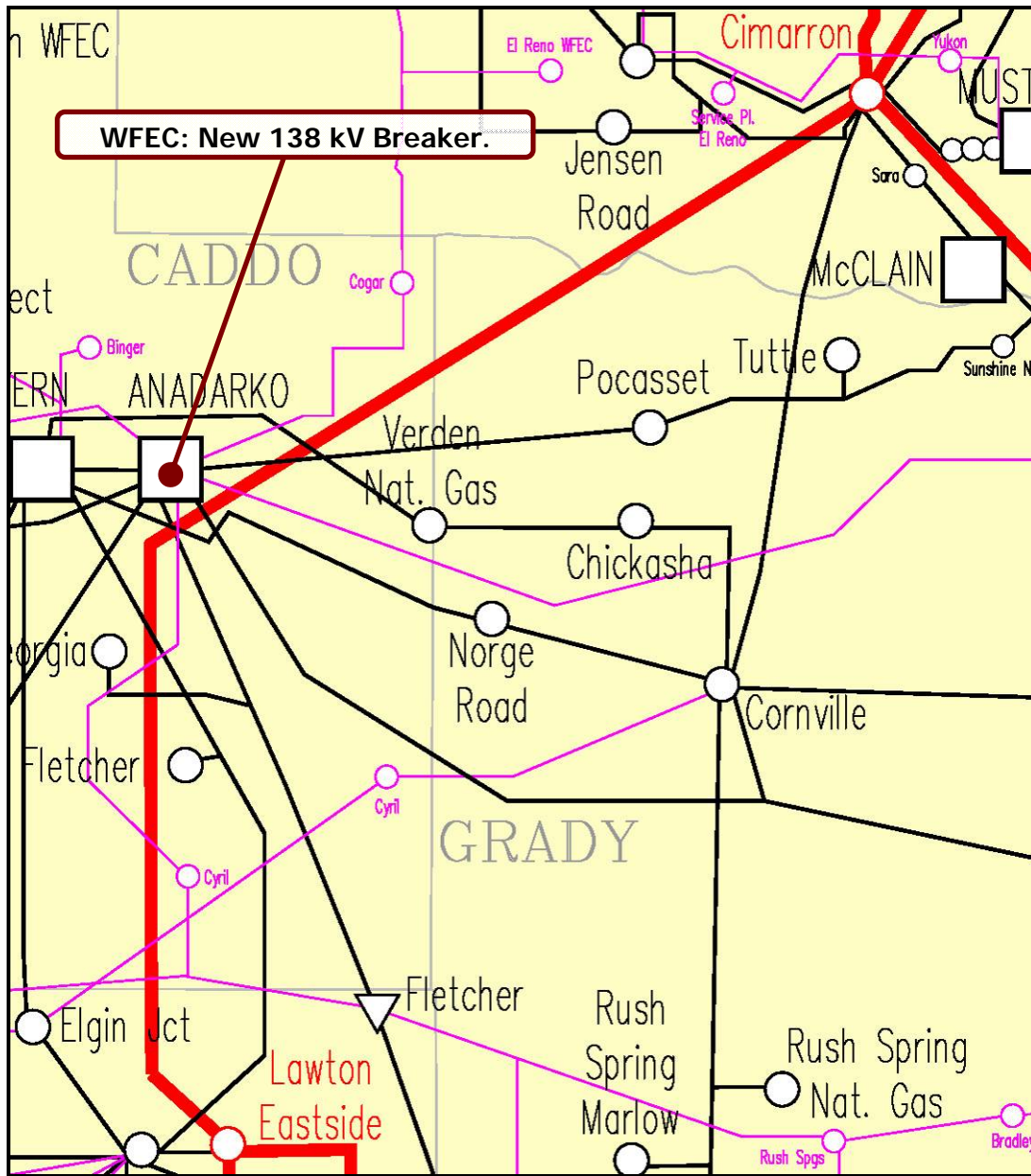

Figure 2: Point of Interconnection Area Map