



***Impact Study for Generation
Interconnection Request
GEN-2006-025***

***SPP Tariff Studies
(#GEN-2006-025)***

July 2007

Summary

Pursuant to the tariff and at the request of the Southwest Power Pool (SPP), ABB Grid Systems Consulting (ABB) performed the following Impact Study to satisfy the Impact Study Agreement executed by the requesting customer and SPP for SPP Generation Interconnection request GEN-2006-025. The request for interconnection was placed with SPP in accordance SPP's Open Access Transmission Tariff, which covers new generation interconnections on SPP's transmission system.

Facilities

The Customer has asked to interconnect 150MW of additional wind generation to their initial generation interconnection request GEN-2005-015 on the Tuco – Oklaunion 345kV line, on the portion of the line owned by Southwestern Public Service (SPS). The requirements for interconnection of the additional 150MW may consist of building no new Transmission Owner Interconnection facilities or Network Upgrades. The Customer's substation transformer's 345kV high side will be paralleled by the Customer with the substation transformer for interconnection request GEN-2005-015. This 150MW request and the original 150MW request will share the Customer's 345kV connection to the 345kV ring bus to be constructed by SPS for GEN-2005-015.

The total cost for building a new 345kV 3-breaker ring switching station, the required interconnection facility for GEN-2005-015, is estimated at \$10,394,192. Whether there is an incremental cost for adding the additional 150MW for GEN-2006-025 will be determined in the Facility Study. A switching surge study (EMTP study) may need to be completed during the Facility Study. The EMTP study may determine that different size line reactors are required at the 345kV ring bus.

The Impact Study determined that to compensate for reactive power losses in the wind turbine collector system and wind turbine generator step transformers that a total of 34 Mvar of 34.5kV capacitor banks are required on the 34.5kV side of the Customer transformer in the Customer substation.

The Impact Study determined that with the Customer requested Gamesa G87 2.0MW wind turbines, the wind farm will meet FERC Order #661A requirements for low voltage ride through (LVRT). If the Customer changes their choice of wind turbines, an Impact re-study will be necessary to determine the effects of this change.

The costs of interconnecting the facility to the SPS transmission system are listed in Table 1 & 2. **These costs do not include any cost that might be associated with short circuit study results.** These costs will be determined when and if a Facility Study is conducted.

Table 1: Direct Assignment Facilities

Facility	ESTIMATED COST (2007 DOLLARS)
Customer – 345-34.5 kV Substation facilities.	*
Customer – 345kV transmission line facilities between Customer facilities and SPS 345kV switching station	*
Customer - Right-of-Way for Customer facilities.	*
Customer – (1) 34.5kV, 34MVAR capacitor bank in Customer substation	*
Total	*

Note: *Estimates of cost to be determined by Customer.

Table 2: Required Interconnection Network Upgrade Facilities

Facility	ESTIMATED COST (2007 DOLLARS)
SPS – Build 345kV, 3-breaker ring bus switching station. Station to include breakers, switches, control relaying, high speed communications, all structures and metering and other related equipment (needed for GEN-2005-015). Costs includes two 345kV line reactors, transmission work, and relay work at nearby substations	\$10,394,192
Total for GEN-2005-015 and GEN-2006-025	\$10,394,192

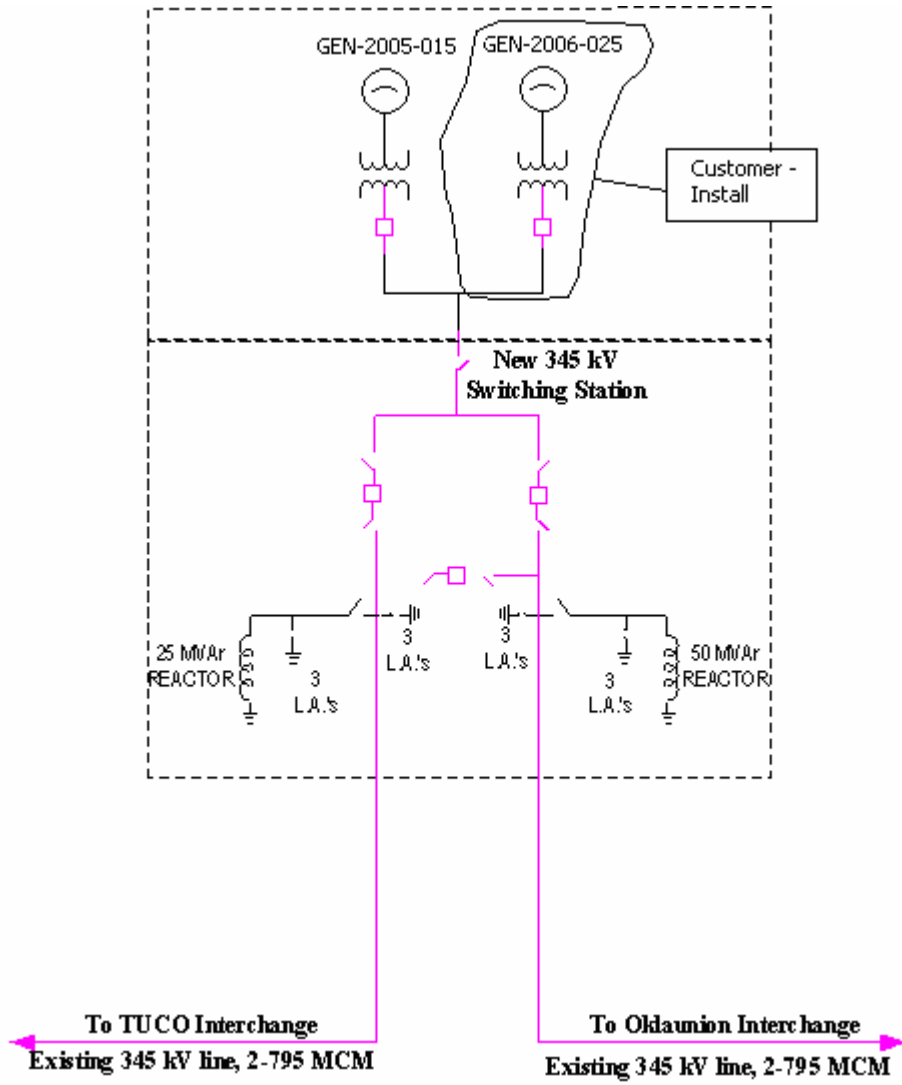

Figure 1. One-Line of Interconnection Facility



**POWER SYSTEMS DIVISION
GRID SYSTEMS CONSULTING**

**IMPACT STUDY FOR GENERATION
INTERCONNECTION REQUEST
GEN-2006-025**

FINAL REPORT

REPORT NO.: 2007-11523-R0
Issued: July 19, 2007

**ABB Inc.
Power Systems Division
Grid Systems Consulting
940 Main Campus Drive, Suite 300
Raleigh, NC 27606**

Legal Notice

This document, prepared by ABB Inc., is an account of work sponsored by Southwest Power Pool (SPP). Neither SPP nor ABB Inc, nor any person or persons acting on behalf of either party: (i) makes any warranty or representation, expressed or implied, with respect to the use of any information contained in this report, or that the use of any information, apparatus, method, or process disclosed in this report may not infringe privately owned rights, or (ii) assumes any liabilities with respect to the use of or for damages resulting from the use of any information, apparatus, method, or process disclosed in this document.

Southwest Power Pool	No. 2007-11523-R0	
Impact Study for Generation Interconnection request GEN-2006-025	7/19/2007	# Pages 23

Author(s):

Sunil Verma

Reviewed by:

Bill Quaintance
Amit Kekare

Approved by:

Willie Wong

Executive Summary

Southwest Power Pool (SPP) has requested a generator interconnection study through the Tariff for a 345 kV interconnection for 150 MW wind farm in Motley County, Texas. This wind farm will be interconnected into a previously studied switching station on the Tuco-Oklahoma 345 kV transmission line. This line is a joint owned tie line between Southwestern Public Service and AEP. The substation to be built will be within the Southwestern Public Service portion of the 345 kV line. As per the developer’s request a study case of 100% MW output (with dynamic reactive compensation if required) was studied. Runs shall also be made to determine maximum MW with no upgrades. As per the developer’s request, 150 MW of additional generation is to be installed using Gamesa G87 2.0 MW turbines. Selected three Phase (3 PH) and Single-line-to-ground (SLG) line faults for specified duration including re-closing were simulated on the SPP system for Winter Peak 2009 and Summer Peak 2011 system conditions.

The SPP system would be stable following all the simulated faults. Based on the results of the stability analysis, it is concluded that the proposed capacity addition of 150 MW with Gamesa G87 2.0 MW turbines does not adversely impact the stability of the SPP system. The wind farm stays online for all the faults simulated. The present low-voltage ride-through capability of the Gamesa G87 2.0 MW should suffice for the GEN-2006-025 wind farm to avoid unnecessary and nuisance tripping of generation following transmission faults.

The results of this analysis are based on available data and assumptions made at the time of conducting this study. If any of the data and/or assumptions made in developing the study model change, the results provided in this report may not apply.

Rev No.	Revision Description	Date	Authored by	Reviewed by	Approved by
0	Final Report	7/19/2007	Sunil Verma	Bill Quaintance	Willie Wong

DISTRIBUTION:

Charles Hendrix – Southwest Power Pool

Further stability study shows that the wind farm using the Gamesa wind turbines will meet the provisions of FERC Order #661A's Low Voltage Ride Through (LVRT) provisions.

The results of this analysis are based on available data and assumptions made at the time of conducting this study. If any of the data and/or assumptions made in developing the study model change, the results provided in this report may not apply.

TABLE OF CONTENTS

1	INTRODUCTION	10
2	STABILITY ANALYSIS	12
2.1	STABILITY ANALYSIS METHODOLOGY	12
2.2	STUDY MODEL DEVELOPMENT	13
2.3	STUDY RESULTS	23
3	CONCLUSIONS	24
APPENDIX A -	Wind Farm Model Development	25
APPENDIX B -	Load Flow and Stability Data	25
APPENDIX C -	Plots for Stability Simulations	25

1 INTRODUCTION

SPP has requested an interconnection impact study for a 150 MW wind farm in Motley County, Texas. This wind farm will be interconnected into a previously studied switching station on the Tuco-Oklaunion 345 kV transmission line. This line is a joint owned tie line between Southwestern Public Service and AEP. The substation to be built will be within the Southwestern Public Service portion of the 345 kV line. The feasibility (power flow) study was not performed as a part of this study.

The objective of the impact study is to evaluate the impact on system stability after connecting the additional 150 MW wind farm to the interconnection point and its effect on the nearby transmission system and generating stations. The study is performed on two system scenarios: 2007 Winter Peak and the 2011 Summer Peak, provided by SPP. Figure 1-1 shows the location of the proposed 150 MW wind farm interconnecting station and Figure 1-2 shows a one-line diagram of the interconnection with the existing network.

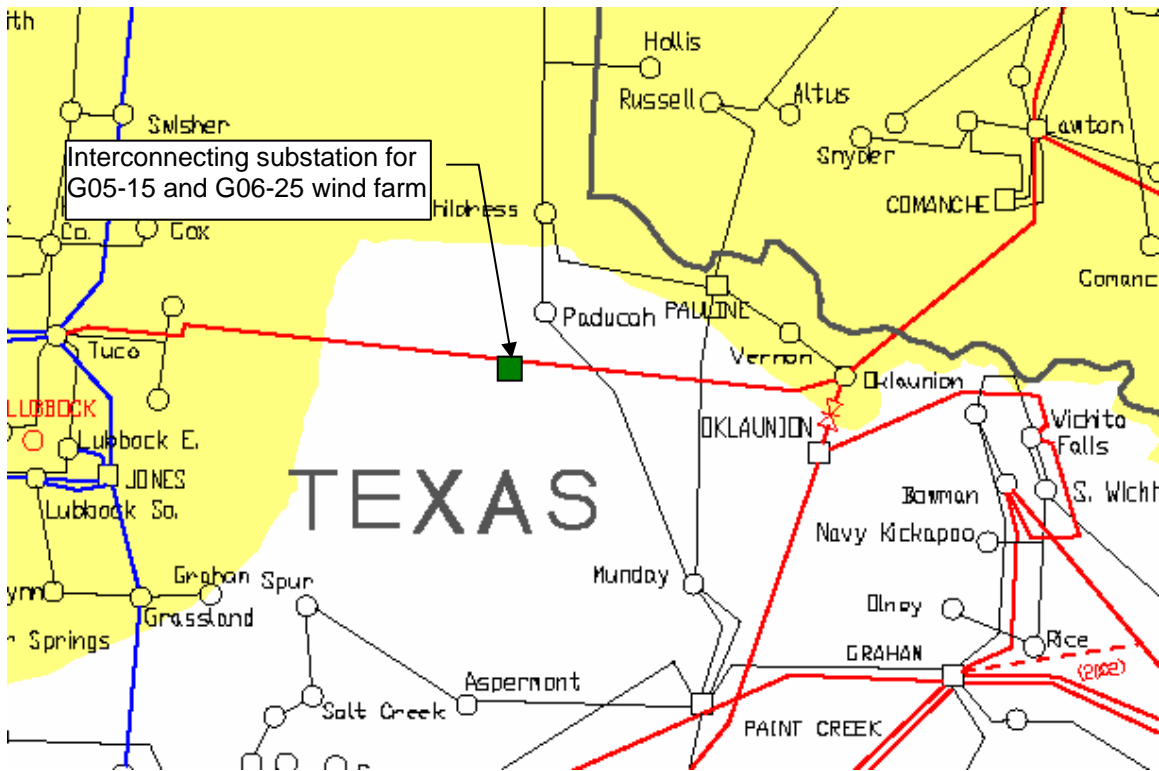

Figure 1-1 Wind farm (G05-15 and G06-25) interconnecting substation

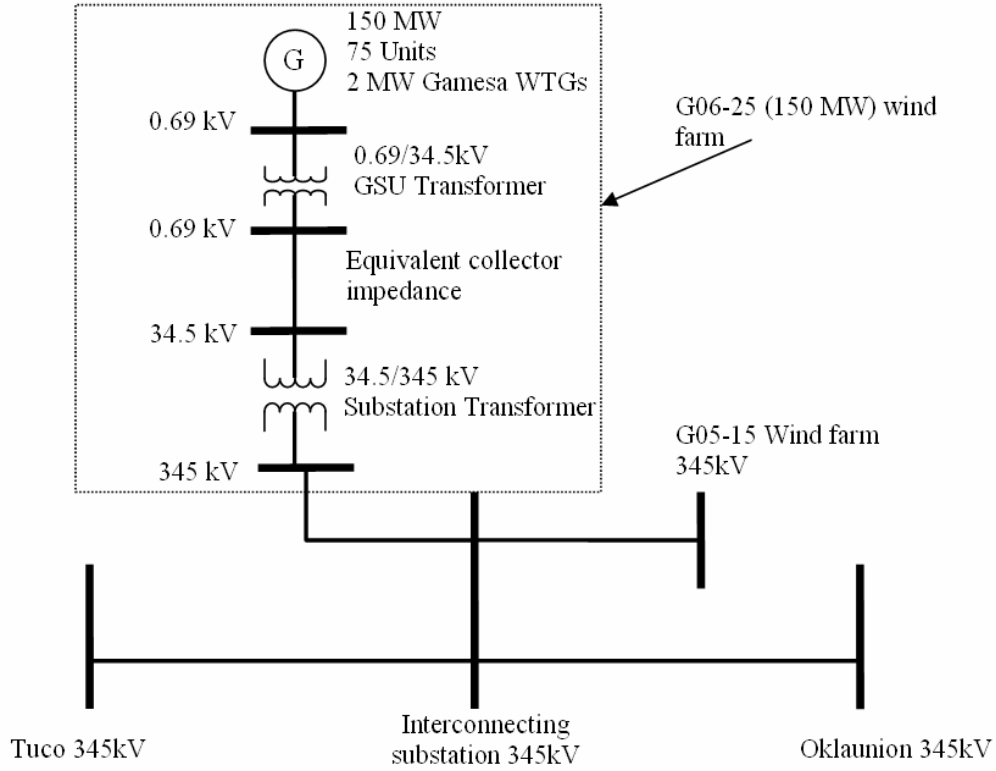

Figure 1-2 Proposed 150 MW wind farm interconnection

2 STABILITY ANALYSIS

In this stability study, ABB investigated the stability of the system for a series of faults specified by SPP, which are in the vicinity of the proposed plant. Most of the simulations represent three-phase or single-phase faults cleared by primary protection in 2.5-5 cycles, re-closing after 20-30 more cycles with the fault still on, and then permanently clearing of the fault 2.5-5 cycles later with primary protection.

2.1 STABILITY ANALYSIS METHODOLOGY

Using Planning Standards approved by NERC, the following stability definition was applied in the Transient Stability Analysis:

“Power system stability is defined as that condition in which the differences of the angular positions of synchronous machine rotors become constant following an aperiodic system disturbance.”

In addition, new wind generators (which are usually asynchronous) are required to stay on-line following normally cleared faults at the Point of Interconnection (POI).

Stability analysis was performed using Siemens-PTI's PSS/E™ dynamics program V29. Three-phase and single-phase line faults were simulated for the specified durations, including re-closing, and the synchronous machine rotor angles were monitored to make sure they maintained synchronism following the fault removal. Stability of asynchronous machines was monitored as well.

Single-phase line faults were simulated with the standard method of applying fault impedance to the positive sequence network to represent the effect of the negative and zero sequence networks on the positive sequence network. The fault impedance was computed to give a positive sequence voltage at the fault location of approximately 60% of pre-fault voltage, which is a typical value.

The ability of the wind generators to stay connected to the grid during the disturbances and during the fault recovery was monitored. This is primarily determined by their low-voltage ride-through capabilities, or lack thereof, as represented in the models by low-voltage trip settings. The Gamesa G87 2.0 MW model is equipped with over/under voltage relays and over/under frequency relays. However, the over/under frequency tripping was disabled while performing the transient stability studies.

2.2 STUDY MODEL DEVELOPMENT

The study model consists of power flow cases and dynamics databases, developed as follows.

Power Flow Base Case

SPP provided two (2) Pre-project PSS/E power flow cases called “*gen06-25_07wp_base.sav*” representing the Winter Peak conditions of the SPP system for the year 2007 and the “*gen06-25_11sp_base.sav*” representing the Summer Peak conditions of the SPP system for the year 2011. Through discussions with SPP, some modifications in prior-queued generation were made as follows:

- change in generator transformer impedance in existing phase-I project from 6% to 0.0105%+j11.25% @ 2.35 MVA
- modification of line (#51536 to #51537) resistance from 0.0049 pu to 0.00049 pu
- 07wp case: 21 MVAR shunt capacitance added at #51538
- 11sp case: modify shunt capacitance from 20 MVAR to 21 MVAR at #51538
- Fix phase shifter in MAPP region 07wp case to avoid high voltage warnings

The modified base cases are then stored into two pre-project cases “*gen06-25_07wp_base_mod.sav*” & “*gen06-25_11sp_base_mod.sav*”.

Figure 2-1 and Figure 2-2 show the local system flows and voltages calculated for the base cases without the wind farm represented. Figure 2-1 is for the winter peak conditions and Figure 2-2 is for the summer peak conditions.

Wind Farm Power Flow Model

The proposed GEN-2006-025 project is comprised of 75 Gamesa G87 2.0 MW wind turbine generators. The plant will be connected to the interconnection substation bus (#51536) at the Tuco-Oklaunion 345 kV transmission line with 34.5/345 kV transformer. The proposed project was added to the Pre-project cases and the generation was dispatched by scaling down generation in areas 502, 524, 525, 536, 540, 541, 544. The Table 2-1 shows the details for the same. Two power flow cases with GEN-2006-025 were established:

- *gen06-25_07wp_base_SPP150.sav* – a 2007 winter peak case
- *gen06-25_11sp_base_SPP150.sav* – a 2011 summer peak case

Table 2-1: GEN-2006-025 project details

System condition	MW	Location	Point of Interconnection	Sink
Winter Peak	150	Motley County, Texas	Substation at Tuco-Oklaunion 345 kV line (#51536)	Areas 502, 524, 525, 536, 540, 541, 544
Summer Peak	150	Motley County, Texas	Substation at Tuco-Oklaunion 345 kV line (#51536)	Areas 502, 524, 525, 536, 540, 541, 544

The GEN-2006-025 wind farm has 75 Gamesa G87 2.0 MW wind turbine generators. These are represented as a single equivalent machine. The equivalent generator is then connected to a 0.69/34.5 kV transformer through single equivalent GSU transformer and a single equivalent collector branch. This model is connected to the full SPP system model through a 34.5/345 kV transformer and a small transmission line. The detailed process of wind farm model development is described in Appendix A. Figure 2-3 and Figure 2-4 show the power flow diagrams for Winter Peak and Summer Peak system conditions respectively with the proposed wind farm in-service.

SPP requires that new wind farms be compensated to unity power factor (0 Mvar exchange) at the POI. For GEN-2006-025, the Mvar flow is maintained at zero at the 345 kV bus by adding 34 MVAR of capacitors at the GEN-2006-025 collector system 34.5 kV bus in both the Winter and Summer Peak cases.

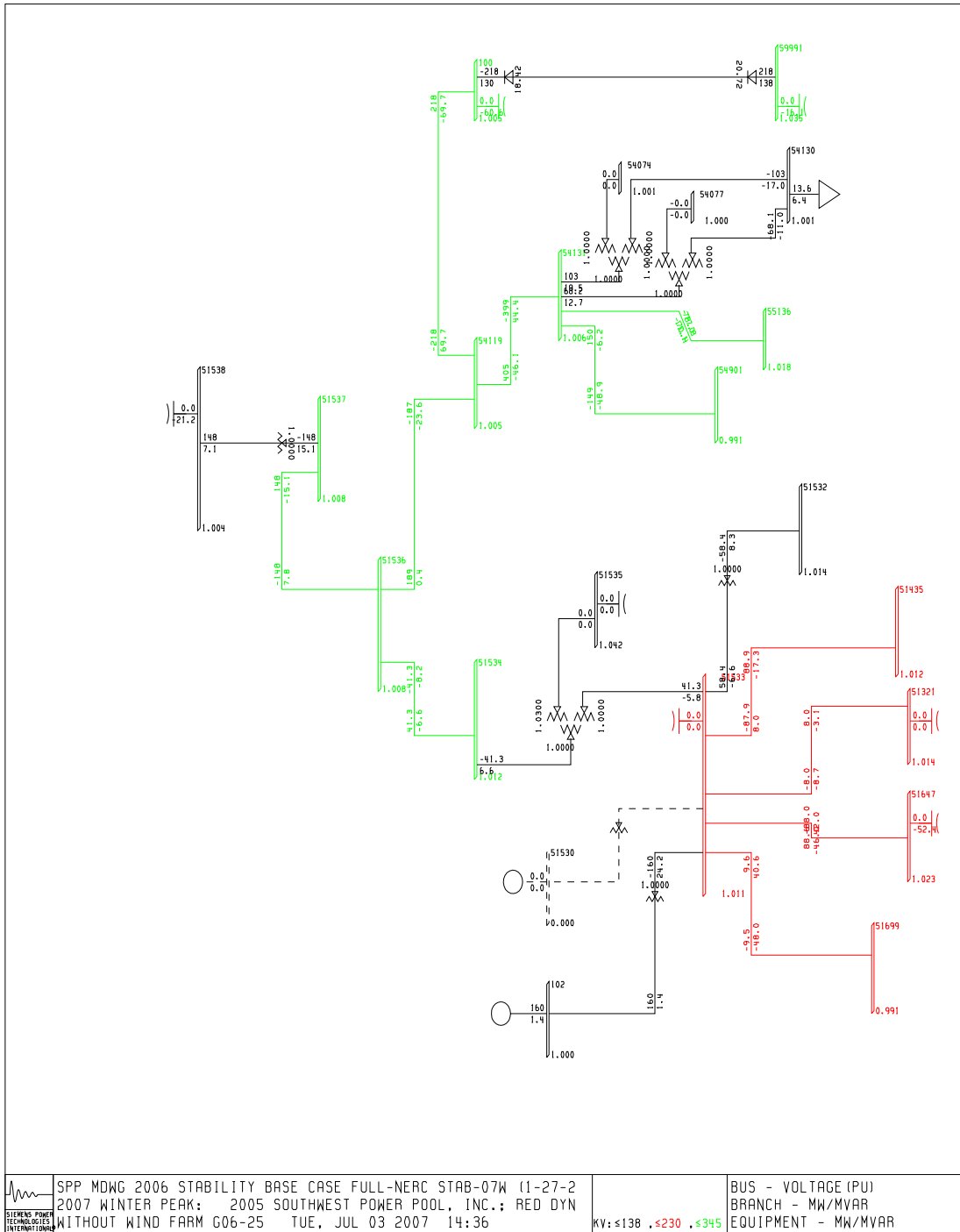

Figure 2-1 Winter Peak Flows and Voltages without GEN-2006-025

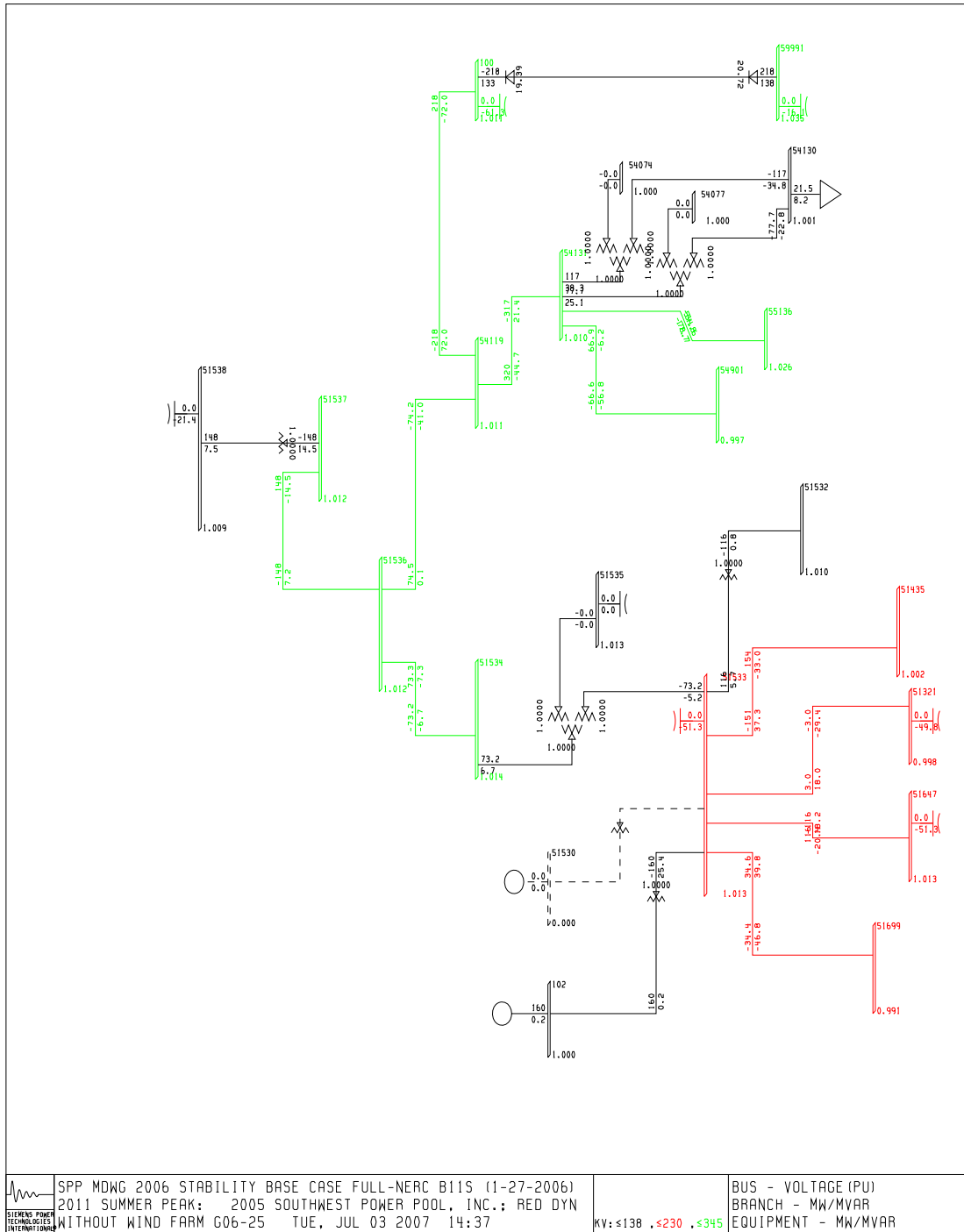

Figure 2-2 Summer Peak Flows and Voltages without GEN-2006-025

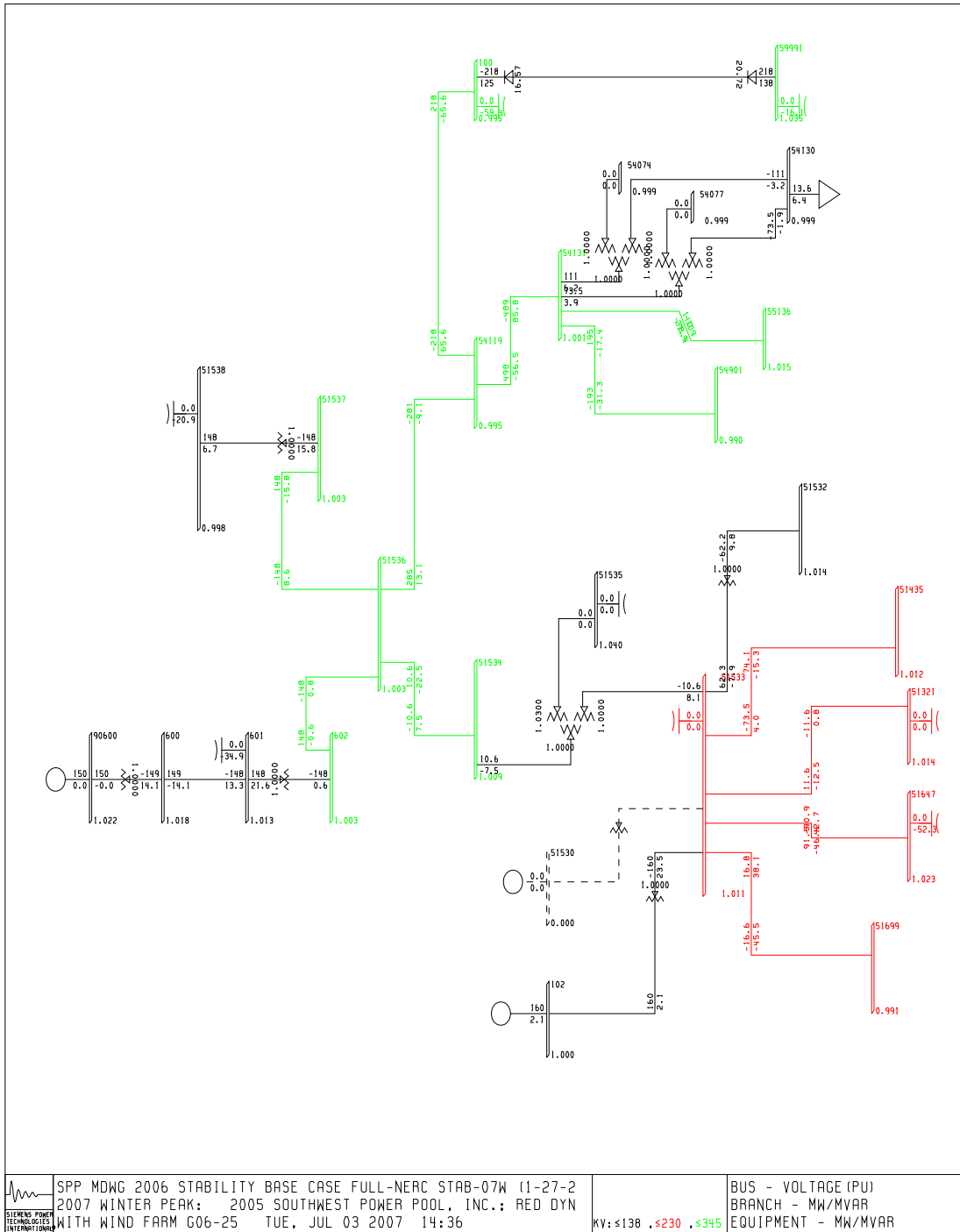

Figure 2-3 Winter Peak Flows and Voltages with GEN-2006-025

Stability Database

SPP provided the stability database in the form of PSS/E dynamic data files, “gen06-25_07wp_base.dyr” to model the 2007 Winter Peak configuration, and “gen06-25_11sp_base.dyr” to model the 2011 Summer Peak configuration. Command files were also provided to compile and link user-written models. These files are compatible with PSS/E version 29.

The stability data for GEN-2006-025 was appended to the Pre-project data. The Gamesa stability model incorporates the voltage ride-through capability with the following settings:

Voltage Limit (pu)	Time Delay (s)
0.15	0.04
0.3	0.625
0.45	1.1
0.6	1.575
0.75	2.05
0.9	2.55
1.1	0.06

The power flow and stability model representations for GEN-2006-025 are included in Appendix B.

Table 2-2 lists the disturbances simulated for stability analysis.

Table 2-2 List of Faults for Stability Analysis

Fault Name	Description
FLT_1_3PH	Three phase fault on the Oklaunion (#54119) to the Wind Farm Switching Station (#51536) 345 kV line, near the Wind Farm. <ul style="list-style-type: none"> a) Apply fault at the Wind Farm Switching Station 345 kV bus. b) Clear Fault after 4 cycles by removing the 345 kV line from the Wind Farm to Oklaunion and removing the line reactor from service. c) Wait 30 cycles, and then re-close the line in (b) back into the fault. d) Leave fault on for 4 cycles, then trip the line in (b) and remove fault.

Fault Name	Description
FLT_2_1PH	<p>Single phase fault on the Oklaunion (#54119) to the Wind Farm Switching Station (#51536) 345 kV line, near the Wind Farm.</p> <ol style="list-style-type: none"> Apply fault at the Wind Farm Switching Station 345 kV bus. Clear Fault after 4 cycles by removing the 345 kV line from the Wind Farm to Oklaunion and removing the line reactor from service. Wait 30 cycles, and then re-close the line in (b) back into the fault. Leave fault on for 4 cycles, then trip the line in (b) and remove fault.
FLT_3_3PH	<p>Three phase fault on the Wind Farm Switching Station (#51536) to Tuco (#51534) 345 kV line, near the Wind Farm.</p> <ol style="list-style-type: none"> Apply fault at the Tuco 345 kV bus. Clear fault after 5 cycles by removing the 345 kV line from Tuco to the Wind Farm Switching Station and the Tuco 345/230kV autotransformer. Wait 30 cycles, and then re-close the line and autotransformer in (b) into the fault. Leave fault on for 5 cycles, then trip the line and autotransformer in (b) and remove fault.
FLT_4_1PH	<p>Single phase fault on the Wind Farm Switching Station (#51536) to Tuco (#51534) 345 kV line, near the Wind Farm.</p> <ol style="list-style-type: none"> Apply fault at the Tuco 345 kV bus. Clear fault after 5 cycles by removing the 345 kV line from Tuco to the Wind Farm Switching Station and the Tuco 345/230kV autotransformer. Wait 30 cycles, and then re-close the line and autotransformer in (b) into the fault. Leave fault on for 5 cycles, then trip the line and autotransformer in (b) and remove fault.
FLT_5_3PH	<p>Three phase fault on the Oklaunion (54119) to Lawton Eastside (54131) 345V line, near Lawton East Side.</p> <ol style="list-style-type: none"> Apply Fault at the Lawton East Side bus. Trip the line after 2.5 cycles by removing the line from Oklaunion to Lawton ES and the Oklaunion HVDC tie (<i>with capacitors at both ends tripping</i>), and remove the fault. Wait 30 cycles, and then re-close the line in (b) into the fault. Leave fault on for 2.5 cycles, then trip the line in (b) and remove fault.

Fault Name	Description
FLT_6_1PH	<p>Single phase fault on the Oklaunion (54119) to Lawton Eastside (54131) 345V line, near Lawton East Side.</p> <ol style="list-style-type: none"> Apply Fault at the Lawton East Side bus. Trip the line after 2.5 cycles by removing the line from Oklaunion to Lawton ES and the Oklaunion HVDC tie (<i>with capacitors at both ends tripping</i>), and remove the fault. Wait 30 cycles, and then re-close the line in (b) into the fault. Leave fault on for 2.5 cycles, then trip the line in (b) and remove
FLT_7_3PH	<p>Three phase fault on the Tuco (#51533) to Tolk (#51435) 230kV line near Tolk.</p> <ol style="list-style-type: none"> Apply fault at the Tolk 230 kV bus. Clear fault after 5 cycles by tripping the 230kV line from Tolk to Tuco. (No re-close on power plant bus).
FLT_8_1PH	<p>Single phase fault on the Tuco (#51533) to Tolk (#51435) 230kV line near Tolk.</p> <ol style="list-style-type: none"> Apply fault at the Tolk 230 kV bus. Clear fault after 5 cycles by tripping the 230kV line from Tolk to Tuco. (No re-close on power plant bus).
FLT_9_3PH	<p>Three phase fault on the Tuco (51533) to Swisher (51321) 230kV line, near Swisher.</p> <ol style="list-style-type: none"> Apply fault at the Swisher 230kV bus. Clear fault after 5 cycles by tripping the 230kV line from Swisher to Tuco. Wait 20 cycles, and then re-close the line in (b) back into the fault. Leave fault on for 5 cycles, then trip the line in (b) and remove fault.
FLT_10_1PH	<p>Single phase fault on the Tuco (51533) to Swisher (51321) 230kV line, near Swisher.</p> <ol style="list-style-type: none"> Apply fault at the Swisher 230kV bus. Clear fault after 5 cycles by tripping the 230kV line from Swisher to Tuco. Wait 20 cycles, and then re-close the line in (b) back into the fault. Leave fault on for 5 cycles, then trip the line in (b) and remove fault.
FLT_11_3PH	<p>Three phase fault on the Tuco (51533) to Jones (51699) 230kV line near Tuco.</p> <ol style="list-style-type: none"> Apply fault at the Tuco 230kV bus. Clear fault after 5 cycles by tripping the 230kV line from Tuco to Jones (no re-close on power plant bus)

Fault Name	Description
FLT_12_1PH	Single phase fault on the Tuco (51533) to Jones (51699) 230kV line near Tuco. a) Apply fault at the Tuco 230kV bus. b) Clear fault after 5 cycles by tripping the 230kV line from Tuco to Jones (no re-close on power plant bus)
FLT_13_3PH	Three phase fault on the Grapevine (50827) to Elk City (54153) 230kV line near Grapevine. a) Apply fault at the Grapevine 230kV bus. b) Clear fault after 5 cycles by tripping the 230kV line from Grapevine to Elk City. c) Wait 20 cycles, and then re-close line in (b) back into the fault. d) Leave fault on for 5 cycles, then trip the line in (b) and remove fault.
FLT_14_1PH	Single phase fault on the Grapevine (50827) to Elk City (54153) 230kV line near Grapevine. a) Apply fault at the Grapevine 230kV bus. b) Clear fault after 5 cycles by tripping the 230kV line from Grapevine to Elk City. c) Wait 20 cycles, and then re-close line in (b) back into the fault. d) Leave fault on for 5 cycles, then trip the line in (b) and remove fault.
FLT_15_3PH	Three phase fault on the Finney (50858) to Potter 345 kV line near Finney a) Apply fault at the Finney 345 kV bus. b) <i>Clear fault after 3.5 cycles by removing the line from Finney (50858) to Potter 345 kV</i>

2.3 STUDY RESULTS

The results for the simulated disturbances are summarized in Table 2-3.

The plots showing the simulation results are included in Appendix C.

The results of the simulations indicate that all generation remains on-line and stable for the studied faults for both Summer Peak and Winter Peak system conditions¹.

Table 2-3: Results of Initial Stability Simulations

FAULT	Summer Peak 2011	Winter Peak 2007
FLT_1_3PH	STABLE	STABLE
FLT_2_1PH	STABLE	STABLE
FLT_3_3PH	STABLE	STABLE
FLT_4_1PH	STABLE	STABLE
FLT_5_3PH	STABLE	STABLE
FLT_6_1PH	STABLE	STABLE
FLT_7_3PH	STABLE	STABLE
FLT_8_1PH	STABLE	STABLE
FLT_9_3PH	STABLE	STABLE
FLT_10_1PH	STABLE	STABLE
FLT_11_3PH	STABLE	STABLE
FLT_12_1PH	STABLE	STABLE
FLT_13_3PH	STABLE	STABLE
FLT_14_1PH	STABLE	STABLE
FLT_15_3PH	STABLE	STABLE

¹ In the original simulations of Faults 5 and 6, the capacitors were not tripped with the HVDC converters at Oklaunion, which caused GEN-2006-025 to trip on high voltage. However, these capacitors will normally trip with the HVDC converters, and in that case GEN-2006-025 stays on-line.

3 CONCLUSIONS

The objective of this study is to evaluate the power system stability after addition of the GEN-2006-025 wind farm. The study is performed for two system scenarios: the 2007 Winter Peak and the 2011 Summer Peak.

To maintain 1.0 power factor at the 345 kV POI, 34 MVAR of capacitors are required at the GEN-2006-025 34.5 kV substation bus for the Summer Peak and Winter Peak cases.

GEN-2006-025 will remain on-line for all studied faults, and the SPP system will be stable following these faults in both Summer Peak and Winter Peak system conditions.

FERC Order 661A Compliance – The wind farm with Gamesa G87 2.0 MW complies with the latest FERC order on low voltage ride through for wind farms. The wind farm will not trip off line for faults 1-4 for voltage relay actuation.

The results of this analysis are based on available data and assumptions made at the time of conducting this study. If any of the data and/or assumptions made in developing the study model change, the results provided in this report may not apply.

APPENDIX A - Wind Farm Model Development

APPENDIX B - Load Flow and Stability Data

APPENDIX C - Plots for Stability Simulations