



***Facility Study for Generation
Interconnection Request
GEN – 2006 – 024S***

***SPP Coordinated Planning
(#GEN-2006-024S)***

June 2007

Summary

Pursuant to the tariff and at the request of the Southwest Power Pool (SPP) Western Farmers Electric Cooperative (WFEC) performed the following Facility Study to satisfy the Facility Study Agreement executed by the requesting customer for SPP Generation Interconnection request Gen-2006-024S. The request for interconnection was placed with SPP in accordance SPP's Open Access Transmission Tariff, which covers new generation interconnections on SPP's transmission system.

***Generation Interconnection
Facilities Study***

For

GEN-2006-024S

Western Farmers Electric Cooperative

June 2007

Table of Contents

Table of Contents	4
Introduction	5
Interconnection Facilities	6
Interconnection Costs	6
One-line Diagram of Buffalo Bear Switching Station	7
Buffalo Area Transmission Map	8

Introduction

The Southwest Power Pool (SPP) has requested a Facility Study for interconnecting a 69kV interconnection for a 19 MW wind farm facility near Buffalo, Oklahoma. This wind farm will be interconnected to a new switch station on the Fort Supply-Buffalo transmission line owned by Western Farmers Electric Cooperative (WFEC). The wind-farm consists of nine Suzlon S88, 2.1 MW wind turbines for a total interconnection of 18.9 MW.

The wind farm will be connected to the Fort Supply to Buffalo 69 kV transmission line owned by Western Farmers Electric Cooperative (WFEC) with a new switching station and 1.5 miles 69 KV transmission line.

The purpose of this study is to identify the facilities and their costs that are needed to interconnect the Customer's wind farm with the Southwest Power Pool transmission system. This facilities study is done in conjunction with SPP Feasibility and Impact Studies for Generation Interconnection Request GEN-2006-024s.

Interconnection facilities include a single breaker switch station to interconnect the wind project.

Interconnect to Existing Facilities (See Figures 1 and 2)

Interconnecting the 19 MW Buffalo Bear wind farm to WFEC's Fort Supply-Buffalo Transmission line will require a new switch station to provide adequate service for the wind farm and area loads. The switch station will include a single breaker, circuit switcher, and an open motor operated switch in a ring configuration as shown in the one-line diagram in figure one.

Interconnection Costs

WFEC estimates the cost of this station at \$1,200,000, with a lead time of 18 months for design, procurement and construction of the Buffalo Bear Switch station.

Short Circuit Fault Duty Evaluation

It is standard practice for WFEC to recommend replacing a circuit breaker when the current through the breaker for a fault exceeds 100% of its interrupting rating with recloser de-rating applied, as determined by the ANSI/IEEE C37.5-1979, C37.010-1979 & C37.04-1979 breaker rating methods.

For this generator interconnection, no breakers were found to exceed their interrupting capability after the addition of the Customer's generation and related facilities. WFEC found no breakers that exceeded their interrupting capabilities on the systems. Therefore there are no short circuit upgrade costs associated with the Gen-2006-024S interconnection.

Buffalo Bear Switching Station One-line Diagram

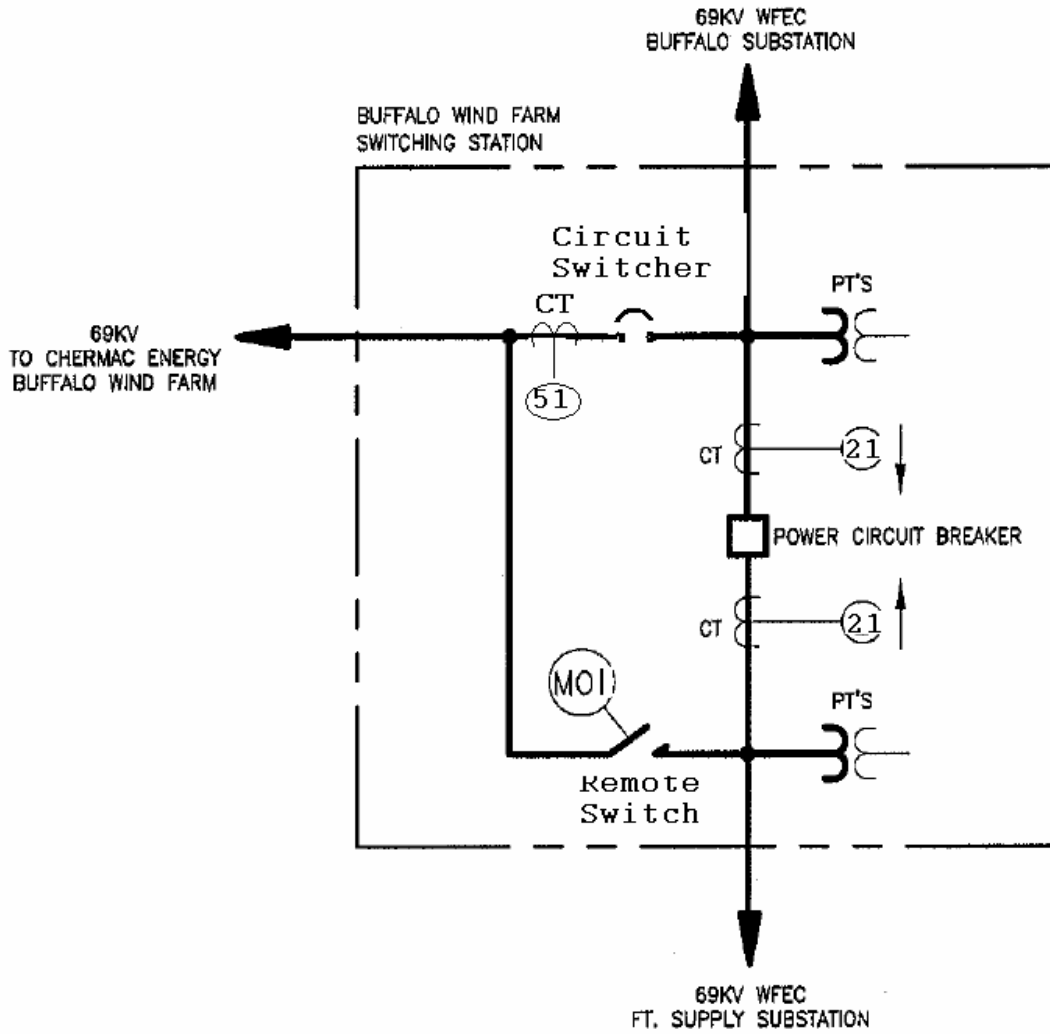

Figure 1

WFEC lines in near Buffalo Bear Wind Project

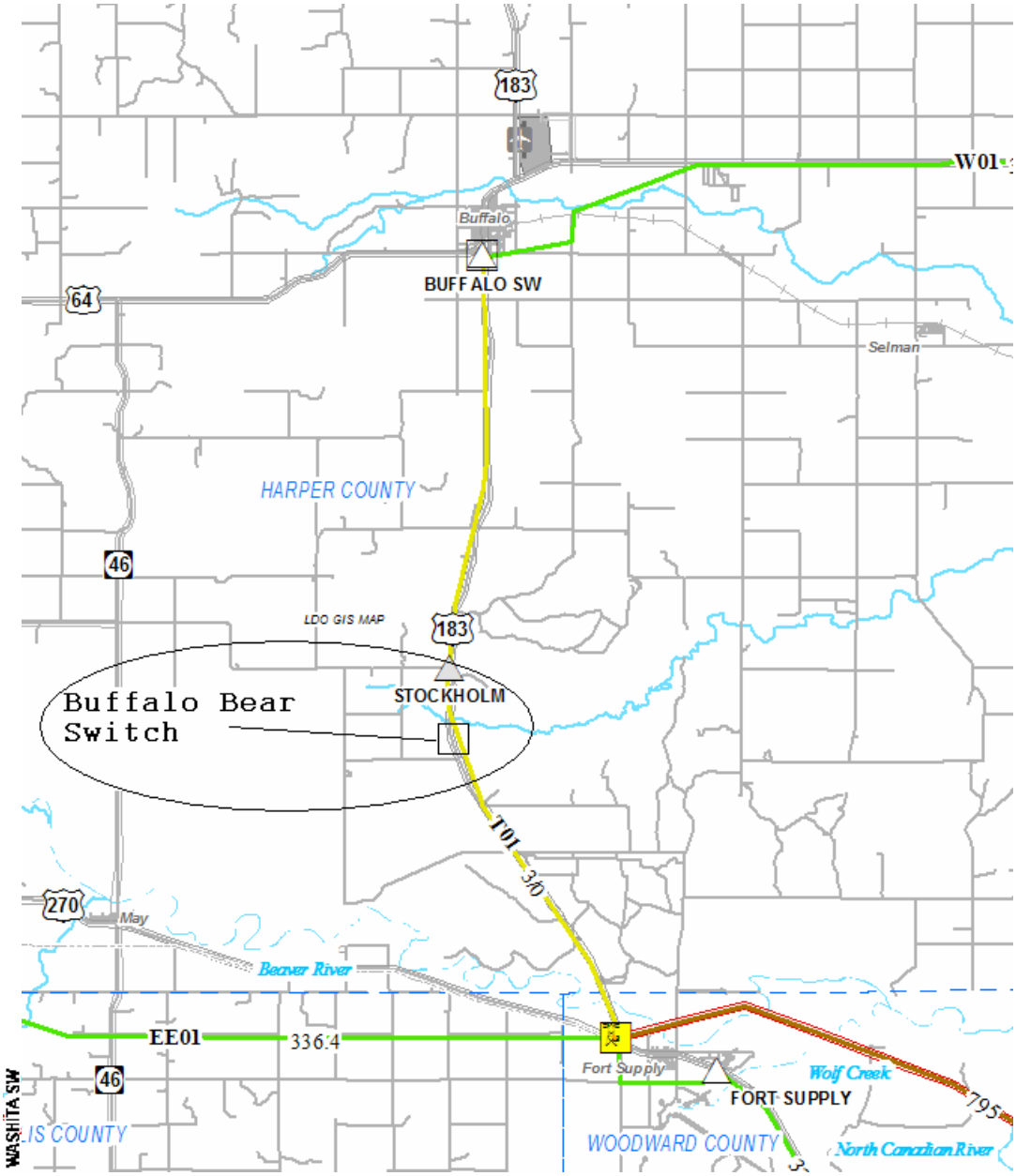

Figure 2 – Map of area Transmission Lines