



***Impact Study for Generation
Interconnection Request
GEN-2006-049***

***SPP Tariff Studies
(#GEN-2006-049)***

April 2009

Summary

Pursuant to the tariff and at the request of the Southwest Power Pool (SPP), S&C Electric Company performed the following Impact Study to satisfy the Impact Study Agreement executed by the requesting customer and SPP for SPP Generation Interconnection request GEN-2006-049. The request for interconnection was placed with SPP in accordance SPP's Open Access Transmission Tariff, which covers new generation interconnections on SPP's transmission system. The Impact Study for GEN-2006-049 was originally studied with Suzlon S88 2.1 MW wind turbines. This restudy analyzed the use of G.E. 1.5 MW wind turbines. This study also took in to account the results of the restudy for GEN-2006-044 in which the GEN-2006-044 interconnection request reduced from 400MW to 370MW and in the process was relieved of being assigned the Woodward – Northwest 345kV transmission line.

Power Factor Requirements

To maintain a unity power factor during normal operation, the Impact Study determined that a total of 18 Mvars of 34.5kV capacitor banks are required for the operation of GEN-2006-049. This capacitor bank(s) should be staged so that excessive voltage variations are not experienced on the SWPS transmission system.

To meet the low voltage requirements of FERC Order #661A, the Impact Study determined that the Interconnection Customer will be required to install (2) 345kV transmission lines to the east. For this study, a 345kV transmission line from Hitchland to Woodward substation and a 345kV transmission line from Woodlawn to Northwest substation was analyzed. The analysis has indicated that stability issues will be alleviated with the addition of these 345kV transmission lines.

Interconnection Facilities

The Customer has requested interconnecting a 400 MW wind farm within the control area of Southwestern Public Service Company (d/b/a Xcel Energy) (SPS). The plant site is located in Stevens County, Kansas to be interconnected into the proposed 345kV substation to be built along the 345 kV Hitchland to Finney transmission line owned by Southwestern Public Service (d/b/a Xcel Energy).. The proposed method of interconnection is to add a new 345kV ring bus terminal to the switching station to be built for GEN-2003-013.

The results of the study indicate that the panhandle area of Texas cannot accommodate any more generation without sufficient outlets to the rest of the SPP transmission system.

Therefore, the interconnection of GEN-2006-049 will require the addition of (2) 345kV transmission lines to the east. For this study, a 345kV transmission line from Hitchland to Woodward substation and a 345kV transmission line from Woodward to Northwest substation was analyzed. The analysis has indicated that stability issues will be alleviated with the addition of these 345kV transmission lines. Therefore, GEN-2006-049 interconnection Customer is responsible for the addition of these transmission lines.

The Impact Study has also determined that with the General Electric turbines provided, the required capacitor banks, and the 345kV transmission lines from Hitchland to Woodward and from Woodlawn to Northwest in service, GEN-2006-049 will meet FERC Order #661A low voltage requirements for low voltage ride through.

The Facility Study currently being conducted for this interconnection request will provide more detailed estimates for these facilities.

Table 1. Interconnection Facilities

FACILITY	ESTIMATED COST (2009 DOLLARS)
CUSTOMER – 345/34.5 kV collector substation facilities.	*
CUSTOMER – (3) 345/34.5 kV transformers and all related 345/34.5 kV switching equipment located at the Customer 345/34.5 kV switching station.	*
CUSTOMER – (1) 345 kV ties between Customer 345/34.5 kV switching station and the point of interconnection.	*
CUSTOMER – Right-of-Way for Customer facilities.	*
CUSTOMER – Capacitor Banks	*
TOTAL	*

* Determined by Customer

Table 2. Network Upgrades

FACILITY	ESTIMATED COST (2009 DOLLARS)
SPS - Add (1) 345 kV terminals to the GEN-2003-013 switching station;	\$3,000,000
SPS-OKGE - Add 345kV terminal at Hitchland and Woodward substations. Build 120 miles of 345kV transmission line from Hitchland to Woodward.	\$165,000,000
TOTAL	\$168,000,000

Final Report

For

Southwest Power Pool

From

S&C Electric Company

**IMPACT STUDY FOR GENERATION
INTERCONNECTION REQUEST
GEN-2006-049**

S&C Project No. 3404

March 31, 2009



S&C Electric Company

©2009 S&C Electric Company. All rights reserved. Permission is granted to Southwest Power Pool (SPP) to copy this document or excerpt there from as required to facilitate the work related to the subject project.

S&C Electric Company, Chicago, IL 60626-3997, Phone: (773) 338-1000

Power Systems Services Division Fax: (773) 338-4254

TABLE OF CONTENTS

EXECUTIVE SUMMARY	1
1. INTRODUCTION	3
2. LOAD FLOW STUDY AND RESULTS.....	3
2.1 <i>MODELING OF WIND TURBINE GENERATORS</i>	<i>5</i>
2.2 <i>POWER FACTOR REQUIREMENTS AT THE POINT OF INTERCONNECTION.....</i>	<i>5</i>
2.3 <i>HITCHLAND TO WOODWARD 345 KV TRANSMISSION LINE PROJECT.....</i>	<i>12</i>
3. DYNAMIC STABILITY SIMULATIONS AND RESULTS	18
3.1. <i>STABILITY CRITERIA.....</i>	<i>21</i>
3.2. <i>MODELING OF WIND TURBINE GENERATORS</i>	<i>21</i>
3.3. <i>PRE-PROJECT SIMULATION RESULTS</i>	<i>22</i>
3.4. <i>POST-PROJECT SIMULATION RESULTS.....</i>	<i>23</i>
4. CONCLUSIONS AND RECOMMENDATIONS.....	26
APPENDIX A STUDY DATA	ERROR! BOOKMARK NOT DEFINED.
APPENDIX B IMPEDANCE CALCULATIONS	ERROR! BOOKMARK NOT DEFINED.
APPENDIX C POST-PROJECT DYNAMIC STABILITY PLOTS	
<i>WITHOUT THE 345 KV HITCHLAND – WOODWARD AND 345 KV WOODWARD - NORTHWEST</i> <i>LINES.....</i>	<i>51</i>
APPENDIX D POST-PROJECT DYNAMIC STABILITY PLOTS	
<i>WITH THE 345 KV HITCHLAND – WOODWARD AND 345 KV WOODWARD - NORTHWEST LINES</i> <i>IN SERVICE.....</i>	<i>244</i>



Report Revision History:

Date of Report	Issue	Comments
March 12, 2009	Rev. A	Final for review and comments
March 31, 2009	Rev. 0	Final report issued

Report prepared by:

George Tsai
Senior Engineer



EXECUTIVE SUMMARY

This system impact study was performed in response to a generation interconnection study request through the Southwest Power Pool Tariff for a 400 MW wind farm in Stevens County, Kansas. The project will consist of 266 General Electric 1.5 MW wind turbine generators and interconnect into a new switching station to be built along the 345 kV Hitchland to Finney transmission line owned by Southwestern Public Service (d/b/a Xcel Energy). The objective of this study was to determine the impact of the interconnection at 100% output power on the stability of nearby areas and prior queued wind farms for winter and summer peak 2010 and identify additional reactive power requirements in order to successfully integrate the project into the transmission system. Three-phase and single-phase-to-ground faults were studied at locations specified by SPP. The same fault contingencies define the N-1 contingencies studied for the steady-state power flow analysis.

Power flow results indicate that as a result of the injection at rated output power from the project into Hitchland, the system will become unstable when the 345 kV line from GEN-2003-013 to Finney is removed from service. Without the project, there are no voltage problems or stability issues. The impact that the project can have on system voltage stability cannot be fixed with switched capacitor banks, STATCON, SVC, or reactive power support. The problem is that there is presently a lack of transmission lines to support the increase of generation. In order to accommodate GEN-2006-049, a 345 kV transmission line from Hitchland to Woodward will be necessary. This line in conjunction with the Northwest – Woodward 345 kV line will alleviate any stability issues for GEN-2006-049.

One of the basic requirements for the wind farm is to be able to control the voltage at the Point of Interconnection (POI). If standard GE turbines with +/- 0.95 power factor range will be acquired for the project, then 18 MVAR total of switched capacitor banks located at the 34.5 kV collector substation (9 MVAR of switched capacitor banks at each substation) will be required to meet a voltage schedule at the POI consistent with the pre-project voltage or 1.0 pu, whichever is higher, considering that the Hitchland to Woodward and Woodward to Northwest 345 kV transmission lines are in service. If the optional GE turbines with +/- 0.90 power factor range will be used instead, then there will be no additional requirement for switched capacitor banks. Whichever the option, the wind farm will need to acquire the GE Wind Farm Management System (WFMS) to control the voltage at the POI.

Dynamic stability analysis results also show that without the Hitchland to Woodward and Woodward to Northwest transmission lines the system will become unstable and prior queued project will disconnect for the following fault contingencies:

- Three-phase faults on the 345 kV GEN-2003-013 to Finney line for both summer and winter.
- Single-phase-to-ground faults on the 345 kV GEN-2003-013 to Finney line for winter only.
- Three-phase faults on the 230 kV Potter to Bushland line for both summer and winter.

The stability problems cannot be addressed with the use of STATCON or SVC.

If the Hitchland to Woodward and Woodland to Northwest 345 kV transmission lines are in service, there will be no stability issues and the project as well as prior queued wind farms will remain connected to satisfy FERC's order 661A provisions on low-voltage ride through (LVRT).

It is a requirement for the project to go in service only after the construction of the 345 kV Hitchland to Woodward and Woodward to Northwest transmission lines is completed and in service.

Introduction

This system impact study was performed in response to a generation interconnection study request through the Southwest Power Pool Tariff for a 400 MW wind farm in Stevens County, Kansas. The proposed wind project, which we will refer to as the “project”, will consist of 266 General Electric 1.5 MW wind turbine generators and interconnect into a new switching station to be built along the 345 kV Hitchland to Finney transmission line owned by Southwestern Public Service (d/b/a Xcel Energy). The objective of this study was to determine the impact of the interconnection at 100% output power on the stability of nearby areas and prior queued wind farms for winter and summer peak 2010 and identify additional reactive power requirements in order to successfully integrate the project into the transmission system. Three-phase and single-phase-to-ground faults were studied at locations specified by SPP. The same fault contingencies constitute the N-1 outage contingencies studied for steady-state analysis.

2. LOAD FLOW STUDY AND RESULTS

Collector system impedance information was provided by the wind farm developer. The wind farm was modeled as aggregate of generators. There is typically no need to model the wind farm project in great detail with each turbine represented individually in order to accurately ascertain the impact of the project on the transmission system. Parameters used for the power flow model are listed in Table 1.

Table 1: GEN-2006-049 Model Parameters

Circuit 1	Parameters
134 GE 1.5 MW wind turbine generators at 0.575 kV	134 * 1.5 MW = 201 MW 134 * 1.58 MVA = 211.72 MVA pf range = +/- 0.95
134 Pad mounted wind turbine generator transformers 0.575 / 34.5 kV transformers	134 * 1.75 MVA = 234.5 MVA X/R = 7.5, %IZ = 5.75 Z1 = 0.0076+ 0.0570j p.u. on 234.5 MVA base Fixed no load tap = flat
Equivalent collector circuit impedance	Z1 = 0.00219 + 0.00252j p.u. on 100 MVA base B1 = 0.0431 p.u. on 100 MVA base
Transformer 1 34.5 / 345 kV transformer	X/R = 20, %IZ = 8.5 Z1 = 0.0042 + 0.0849j p.u. on 132 MVA base Fixed no load tap = flat
345 kV, Two (2) 795 ACSR T-line from transformer 1 to interconnection substation	Length = 14 mile Z1 = 0.0008 + 0.0070j p.u. on 100 MVA base B1 = 0.1167 p.u. on 100 MVA base
Circuit 2	Parameters
132 GE 1.5 MW wind turbine generators at 0.575 kV	132 * 1.5 MW = 198 MW 132 * 1.58 MVA = 208.56 MVA pf range = +/- 0.95
132 Pad mounted wind turbine generator transformers 0.575 / 34.5 kV transformers	132 * 1.75 MVA = 231 MVA X/R = 7.5, %IZ = 5.75 Z1 = 0.0076+ 0.0570j p.u. on 231 MVA base Fixed no load tap = flat
Equivalent collector circuit impedance	Z1 = 0.00234 + 0.00269j p.u. on 100 MVA base B1 = 0.0456 p.u. on 100 MVA base
Transformer 2 34.5 / 345 kV transformer	X/R = 20, %IZ = 8.5 Z1 = 0.0042 + 0.0849j p.u. on 132 MVA base Fixed no load tap = flat
345 kV, Two (2) 795 ACSR T-line from transformer 1 to transformer 2	Length = 2.1 mile Z1 = 0.0001 + 0.0011j p.u. on 100 MVA base B1 = 0.0175 p.u. on 100 MVA base



2.1 Modeling of Wind Turbine Generators

GE 2.1 MW/60 Hz wind turbine generators are variable speed doubly-fed (wound rotor) induction generators with electrical pitch control. At full load, the standard GE turbine can operate continuously between 0.95 leading (capacitive) to 0.95 lagging (inductive), or +/- 0.95 power factor. With an optional upgrade, the turbines can continuously operate between 0.90 leading (capacitive) to 0.90 lagging (inductive), or +/- 0.90 power factor. Each wind turbine should be configured to work with the GE Wind Farm Management System (WFMS) to regulate the voltage at the Point of Interconnection (POI) to any set point chosen by the system operator.

2.2 Power Factor Requirements at the Point of Interconnection

The power factor requirements at the Point of Interconnection (POI) arise from the need by the wind generation project to meet a voltage schedule at the POI consistent with the pre-project voltage or 1.0 pu, whichever is higher, for each of the N-1 contingencies studied. It is understood that it may not be possible to meet the voltage schedule at the POI since it would in some cases require the wind farm to make provisions to operate outside of +/- 0.95 pf and thus are not required. At minimum, system voltages should conform to ANSI C84.1 and be stable.

Without the project, the voltage at the 345 kV GEN-2003-013 bus for each of the N-1 contingencies in Table 2 is listed in Table 3. All cases are stable.

Table 2: List of contingencies specified by SPP

Contingency Number	Description
INTACT	System intact
1_N-1	Outage of the line from GEN-2003-013 to Finney 345kV (90000 – 523853).
2_N-1	Outage of the line from GEN-2003-013 to Hitchland 345kV (90000 – 523097).
3_N-1	Outage of the line from Holcomb – Finney CKT 1 345kV (531449 – 523853).
4_N-1	Outage of the line from Potter – GEN-2005-017 345kV (523961 – 51700).
5_N-1	Outage of the line from Grapevine to Stateline 230kV (523771 – 523777).
6_N-1	Outage of the line from Potter – Plant X 230kV (523959 – 525481).
7_N-1	Outage of the line from Blackhawk – Pringle 115kV (523344 – 523266).
8_N-1	Outage of the line from Potter – Bushland 230kV (523959 – 524267).



Table 3: Pre-Project Voltages at the POI

Contingency Case	Voltage in p.u.	
	Summer Peak 2010	Winter Peak 2010
INTACT	1.004	1.029
1_N-1	0.973	1.020
2_N-1	1.014	1.038
3_N-1	1.004	1.029
4_N-1	0.988	1.016
5_N-1	1.003	1.023
6_N-1	1.002	1.027
7_N-1	1.004	1.029
8_N-1	1.003	1.027

With the project, power flow data of the wind farm for each of the contingencies is listed in Tables 4 and 5. The power flow results show that the power factor requirements are more demanding for winter peak. The power flow results for summer peak indicate the following:

- The wind farm can regulate the voltage at the POI in every case with the exception of 1_N-1 and 4_N-1.
- 1_N-1 will cause the system to become unstable. Dynamic stability results for this load-flow contingency show that multiple wind farms will disconnect from the grid including the project on overfrequency protection. Additional stability analysis runs show that STATCON/SVC cannot be used to address the stability issues.
- 4_N-1 would require the power factor at the POI to exceed FERC 661A minimum operating power factor requirements of +/- 0.95.
- 5_N-1 and 6_N-1 will require additional switched capacitor banks (size not determined) if the standard GE turbine is used. However, the optional upgraded version of the turbine can be used without the need of additional switched capacitor banks.



Table 4: Post-Project Power Flow Summary for Summer Peak
 (GE Wind Farm Management System regulating voltage at the POI to 1.004 pu)

Case	Voltage at POI in pu	Net MW injection	Power Factor at POI in %	Power Factor at WTG in %	Notes
INTACT	1.004	390.4	97.94% lead	96.16% lead	
1_N-1	0.903	0	N/A		<ul style="list-style-type: none"> Multiple wind farms including the project trip off on over frequency STATCON or SVC cannot be used to address the instability issues.
2_N-1	1.004	390.5	99.03% lead	97.66% lead	
3_N-1	1.004	390.4	97.91% lead	96.12% lead	
4_N-1	0.994	389.6	93.33% lead	90.12% lead	<ul style="list-style-type: none"> possible with optional WTG upgrade. WTG's are unable to meet the minimum voltage of 1.0 pu at the POI pf at POI only required between +/- 95 %
5_N-1	1.004	390.3	96.94% lead	94.86% lead	possible with optional WTG upgrade
6_N-1	1.004	390.3	96.87% lead	94.75% lead	possible with optional WTG upgrade
7_N-1	1.004	390.4	97.85% lead	96.03% lead	
8_N-1	1.004	390.3	97.37% lead	95.44% lead	



The power flow results for winter peak indicate the following:

- The wind farm can regulate the voltage at the POI in every case with the exception of 1_N-1, 4_N-1, and 5_N-1.
- 1_N-1 will cause the system to become unstable. Dynamic stability results for this load-flow contingency show that multiple wind farms will disconnect from the grid including the project on overfrequency protection. Additional stability analysis runs show that STATCON/SVC cannot be used to address the stability issues.
- 4_N-1 and 5_N-1 would require the power factor at the POI to exceed FERC 661A minimum operating power factor requirements of +/- 0.95.
- 6_N-1 and 8_N-1 will require switched capacitor banks (size not determined) if the standard GE turbine is used. However, the optional upgraded version of the turbine can be used without the need of additional switched capacitor banks.

Table 5: Post-Project Power Flow Summary for Winter Peak
(GE Wind Farm Management System regulating voltage at the POI to 1.029 pu)

Case	Voltage at POI in pu	Net MW injection	Power Factor at POI in %	Power Factor at WTG in %	Notes
INTACT	1.029	390.7	96.84% lead	96.16% lead	
1_N-1			N/A		<ul style="list-style-type: none"> Multiple wind farms including the project trip off on over frequency STATCON or SVC cannot be used to address the instability issues.
2_N-1	1.029	390.9	98.93% lead	97.85% lead	
3_N-1	1.029	390.7	96.77% lead	95.13% lead	
4_N-1	1.019	389.9	92.75% lead	90.06% lead	<ul style="list-style-type: none"> possible with optional WTG upgrade pf at POI only required between +/- 95 %
5_N-1	1.028	390.2	93.56% lead	91.28% lead	<ul style="list-style-type: none"> possible with optional WTG upgrade pf at POI only required between +/- 95 %
6_N-1	1.029	390.7	95.43% lead	93.50% lead	possible with optional WTG upgrade
7_N-1	1.029	390.6	96.74% lead	95.10% lead	
8_N-1	1.029	390.6	95.97% lead	94.16% lead	possible with optional WTG upgrade



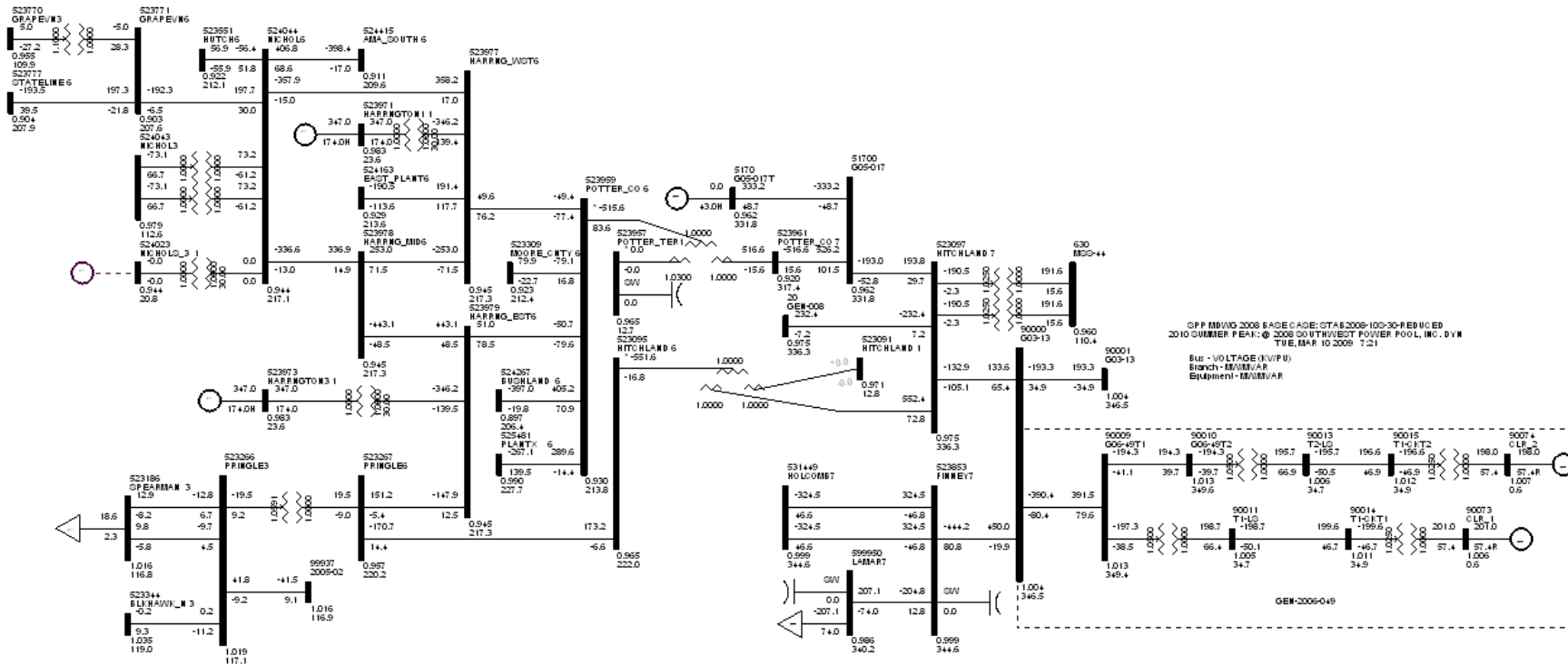

Figure 2: Power flow diagram - Summer Peak 2010



Final Report on
Interconnection Impact Study for Generation Interconnection Request GEN-2006-049

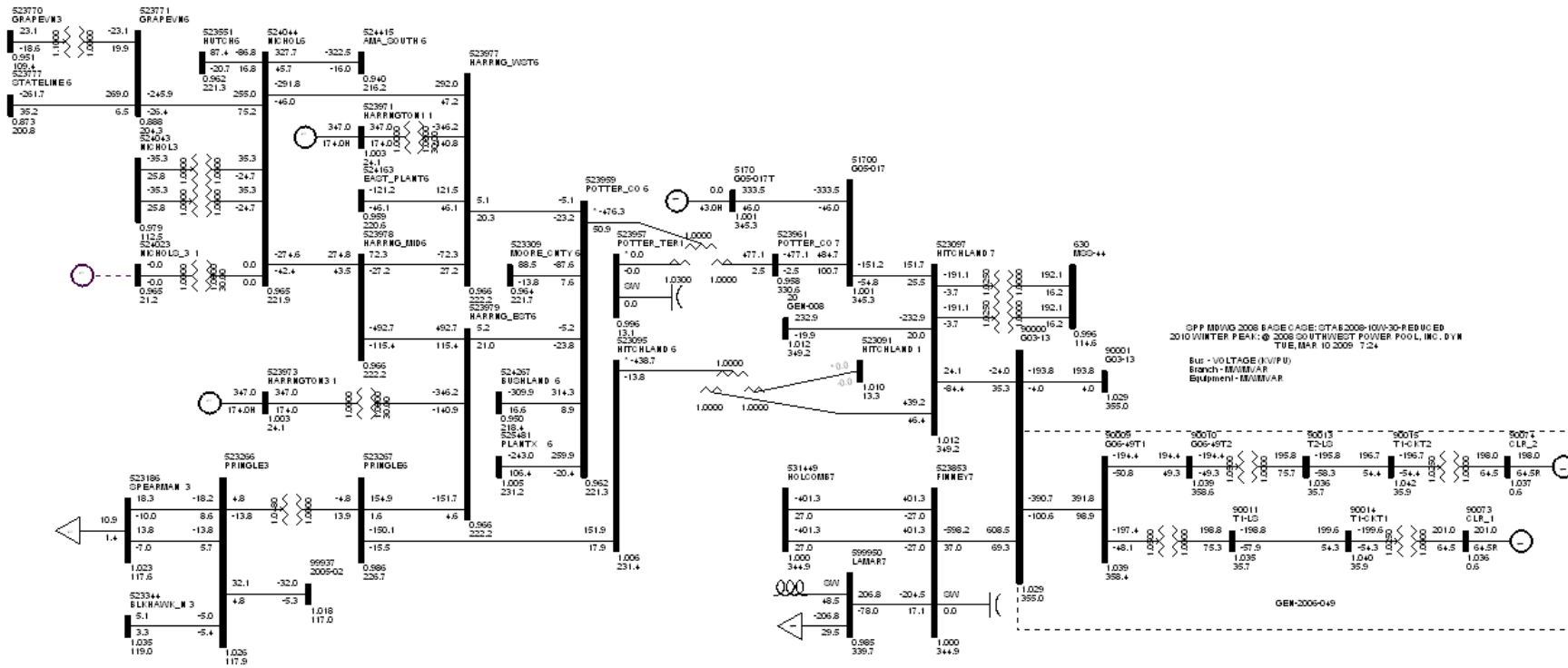

Figure 3: Power flow diagram - Winter Peak 2010



2.3 *Hitchland to Woodward and Woodward to Northwest 345 kV Transmission Line Project*

The key issue is that an outage of the 345 kV line from GEN-2003-013 to Finney 345kV can cause system instability. In this scenario, Hitchland will see a significant increase in megawatt injection due to GEN-2006-049 with GEN-2002-008, GEN-2005-017, and GEN-2003-013 connected to Hitchland. When the 345 kV line from GEN-2003-013 to Finney 345 kV is removed from service, Hitchland will not be able to accommodate the 400 MW generation injection from GEN-2006-049. This is understandably more severe in the winter peak than in the summer peak case. The full 400 MW project cannot be integrated into the transmission system without additional transmission lines.

In order to accommodate GEN-2006-049 a transmission line project from the 345 kV Hitchland substation to Woodward will be needed in conjunction with the 345 kV line from Woodward to Northwest. Figures 4 and 5 are updated power flow diagrams that show the new transmission lines.

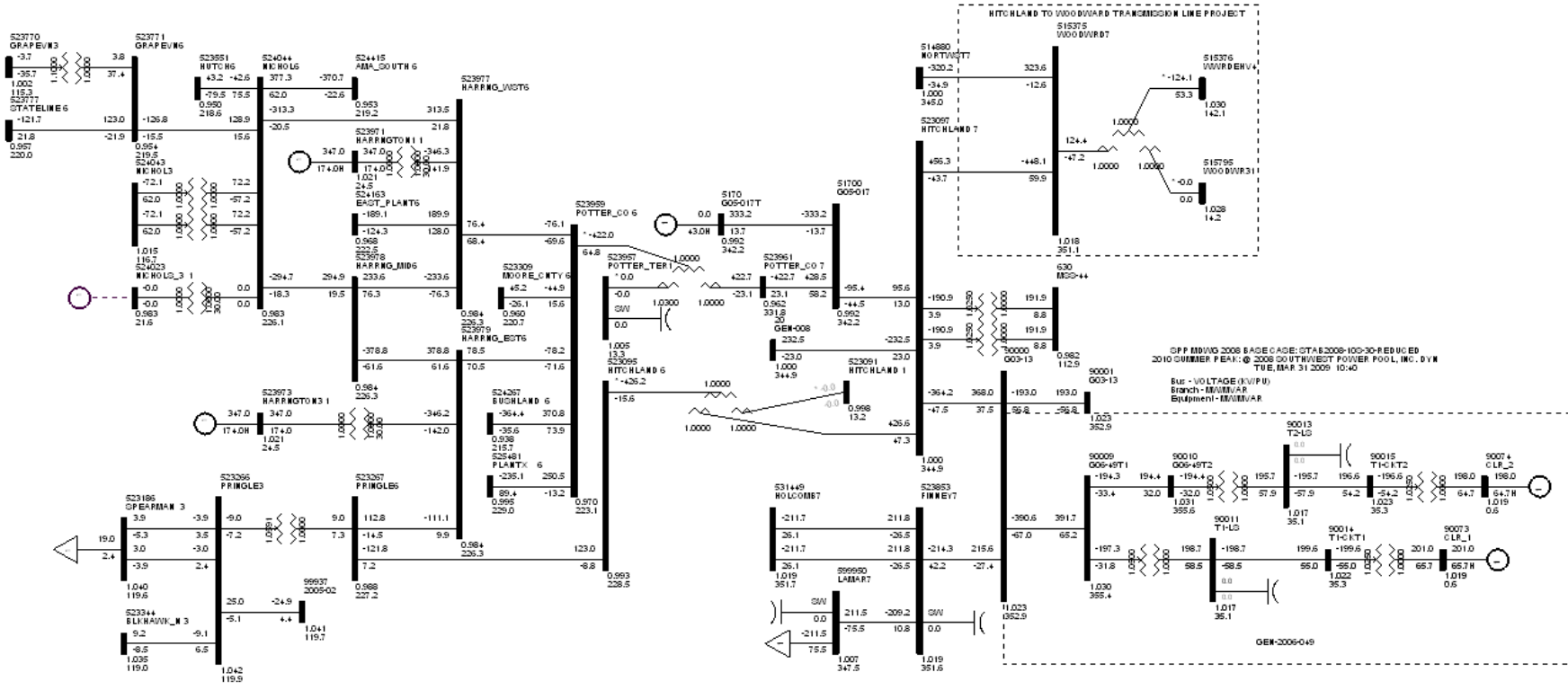

Figure 4: Power flow diagram-Summer Peak 2010 with the Hitchland – Woodward and Woodward – Northwest 345 kV Lines



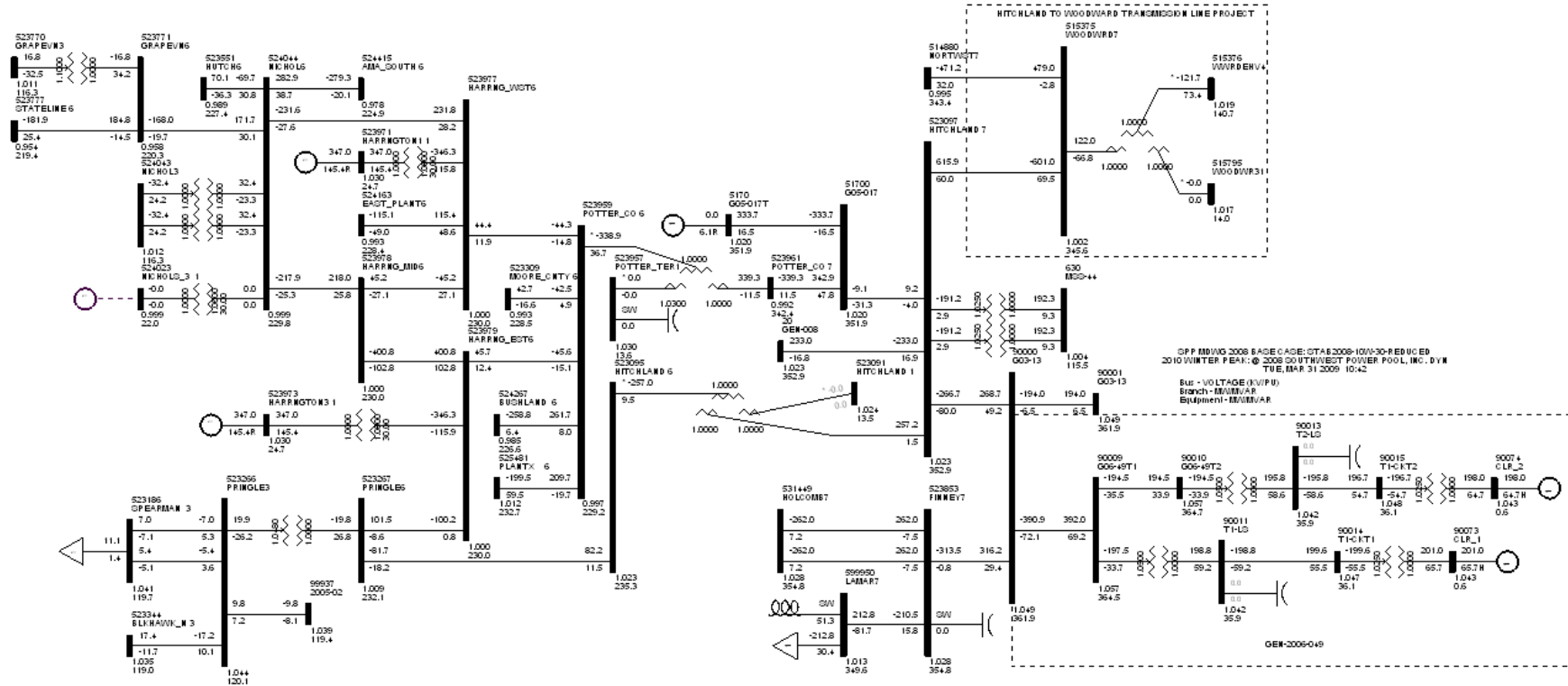

Figure 5: Power flow diagram-Winter Peak 2010 with the Hitchland – Woodward and Woodward – Northwest 345 kV Lines



Without the project, the voltage at the 345 kV GEN-2003-013 bus for each of the N-1 contingencies in Table 2 is listed in Table 6. The voltages in Table 6 are higher than those in Table 3 because the 345 kV Hitchland – Woodward and 345 kV Woodward to Northwest lines are in service. All cases are stable.

Table 6: Pre-Project Voltages at the POI

With 345 kV Hitchland – Woodward and 345 kV Woodward to Northwest lines In Service

Contingency Case	Voltage in p.u.	
	Summer Peak 2010	Winter Peak 2010
INTACT	1.0266	1.0583
1_N-1	1.0195	1.0655
2_N-1	1.0134	1.0491
3_N-1	1.0266	1.0583
4_N-1	1.0222	1.0588
5_N-1	1.0264	1.0569
6_N-1	1.0258	1.0572
7_N-1	1.0269	1.0588
8_N-1	1.0266	1.0577

If standard GE turbines will be used, then 18 MVAR total of switched capacitor banks located at the 34.5 kV collector bus are needed in order to meet the voltage schedule at the POI consistent with the pre-project voltage or 1.0 pu, whichever is higher, for each of the N-1 contingencies studied. Since the wind farm has two separate 34.5 kV collector buses, each would have 9 MVAR of switched capacitor banks and normally be online unless high voltages require them to switch off. The power flow data of the wind farm for each of the N-1 contingencies is listed in Tables 7 and 8 with the power factor at the wind turbine generators corresponding to a standard GE turbine. All cases are stable.

On the other hand, if the optional GE turbines with +/- 0.90 power factor range will be used instead, then there will be no additional requirement for switched capacitor banks. The power flow data of the wind farm for each of the N-1 contingencies is listed in Tables 9 and 10 with the power factor at the wind turbine generators corresponding to a GE turbine with +/- 0.90 power factor range.

Table 7: Post-Project Power Flow Summary for Summer Peak
With 345 kV Hitchland – Woodward and 345 kV Woodward - Northwest lines In Service
GE Wind Turbine Generators with +/- 0.95 Power Factor Range
and 18 MVAR Total of Switched Capacitor Banks at 34.5 kV
(GE Wind Farm Management System regulating voltage at the POI to 1.0266 pu)

Case	Voltage at POI in pu	Net MW injection	Power Factor at POI in %	Power Factor at WTG in %
INTACT	1.0266	390.8	99.7% lead	98.3% lead
1_N-1	1.0234	390.6	97.8% lead	95.2% lead
2_N-1	1.0136	390.4	97.8% lead	95.1% lead
3_N-1	1.0266	390.8	99.7% lead	98.3% lead
4_N-1	1.0263	390.7	98.6% lead	96.5% lead
5_N-1	1.0266	390.8	99.6% lead	98.2% lead
6_N-1	1.0266	390.8	99.5% lead	98.0% lead
7_N-1	1.0266	390.8	99.7% lead	98.3% lead
8_N-1	1.0266	390.8	99.6% lead	98.2% lead

Table 8: Post-Project Power Flow Summary for Winter Peak
With 345 kV Hitchland – Woodward and 345 kV Woodward - Northwest lines In Service
GE Wind Turbine Generators with +/- 0.95 Power Factor Range
and 18 MVAR Total of Switched Capacitor Banks at 34.5 kV
(GE Wind Farm Management System regulating voltage at the POI to 1.0583 pu)

Case	Voltage at POI in pu	Net MW injection	Power Factor at POI in %	Power Factor at WTG in %
INTACT	1.0583	391.3	99.4% lead	98.1% lead
1_N-1	1.0582	391.2	99.0% lead	97.4% lead
2_N-1	1.0519	391.0	97.4% lead	95.1% lead
3_N-1	1.0583	391.3	99.4% lead	98.1% lead
4_N-1	1.0582	391.2	99.0% lead	97.5% lead
5_N-1	1.0582	391.2	99.0% lead	97.5% lead
6_N-1	1.0582	391.2	99.1% lead	97.7% lead
7_N-1	1.0583	391.3	42.5% lead	98.2% lead
8_N-1	1.0582	391.3	99.2% lead	97.9% lead

Table 9: Post-Project Power Flow Summary for Summer Peak
With 345 kV Hitchland – Woodward and 345 kV Woodward - Northwest lines In Service
GE Wind Turbine Generators with +/- 0.90 Power Factor Range
(GE Wind Farm Management System regulating voltage at the POI to 1.0266 pu)

Case	Voltage at POI in pu	Net MW injection	Power Factor at POI in %	Power Factor at WTG in %
INTACT	1.0266	390.7	99.7% lead	97.4% lead
1_N-1	1.0261	390.5	97.3% lead	93.1% lead
2_N-1	1.0265	390.2	95.6% lead	90.7% lead
3_N-1	1.0266	390.7	99.6% lead	97.4% lead
4_N-1	1.0264	390.6	98.6% lead	95.3% lead
5_N-1	1.0266	390.7	99.6% lead	97.2% lead
6_N-1	1.0266	390.7	99.5% lead	97.0% lead
7_N-1	1.0266	390.7	99.7% lead	97.4% lead
8_N-1	1.0266	390.7	99.6% lead	97.3% lead

Table 10: Post-Project Power Flow Summary for Winter Peak
With 345 kV Hitchland – Woodward and 345 kV Woodward - Northwest lines In Service
GE Wind Turbine Generators with +/- 0.90 Power Factor Range
(GE Wind Farm Management System regulating voltage at the POI to 1.0583 pu)

Case	Voltage at POI in pu	Net MW injection	Power Factor at POI in %	Power Factor at WTG in %
INTACT	1.0583	391.3	99.4% lead	98.1% lead
1_N-1	1.0582	391.1	99.0% lead	96.3% lead
2_N-1	1.0583	390.8	96.2% lead	92.1% lead
3_N-1	1.0583	391.2	99.4% lead	97.0% lead
4_N-1	1.0582	391.2	99.0% lead	96.4% lead
5_N-1	1.0582	391.2	99.0% lead	96.4% lead
6_N-1	1.0582	391.2	99.1% lead	96.6% lead
7_N-1	1.0583	391.2	99.4% lead	97.2% lead
8_N-1	1.0582	391.2	99.2% lead	96.8% lead

3. TRANSIENT STABILITY STUDY AND RESULTS

Dynamic simulations were performed for fault contingencies in Table 11 with and without GEN-2006-049 and with and without the Hitchland – Woodward and Woodward – Northwest lines for summer and winter peak 2010.

Table 11: Fault Contingencies

Cont. Number	Cont. Name	Description
1	FLT_1_3PH	a. Apply 3-phase fault at the GEN-2003-013 bus (90000). b. Clear fault after 4 cycles by removing the line from GEN-2003-013 to Finney 345kV (90000 – 523853).
2	FLT_2_1PH	a. Apply 1-phase fault at the GEN-2003-013 bus (90000). b. Clear fault after 4 cycles by tripping the line from GEN-2003-013 to Finney 345kV (90000 – 523853). c. Wait 30 cycles, and then re-close the phase in (b) into the fault. d. Apply fault for 4 cycles, then trip the line in (b), and remove fault.
3	FLT_3_3PH	a. Apply 3-phase fault at the GEN-2003-013 bus (90000). b. Clear fault after 4 cycles by removing the line from GEN-2003-013 to Hitchland 345kV (90000 – 523097).
4	FLT_4_1PH	a. Apply 1-phase fault at the GEN-2003-013 bus (90000). b. Clear fault after 4 cycles by tripping the line from GEN-2003-013 – Hitchland 345kV (90000 – 523097). c. Wait 20 cycles, and then re-close the line in (b) d. Apply fault for 4 cycles, then trip the line in (b) and remove fault.
5	FLT_5_3PH	a. Apply 3-phase fault at the Holcomb bus (531449). b. Clear fault after 4 cycles by removing the line from Holcomb – Finney CKT 1 345kV (531449 – 523853).
6	FLT_6_1PH	a. Apply 1-phase fault at the Holcomb bus (531449). b. Clear fault after 4 cycles by tripping one phase on the line from Holcomb – Finney CKT 1 345kV (531449 – 523853). c. Wait 30 cycles, and then re-close the phase in (b) into the fault. d. Apply fault for 4 cycles, then trip the line in (b).
7	FLT_7_3PH	a. Apply 3-phase fault at the Potter bus (523961). b. Clear fault after 4 cycles by removing the line from Potter – GEN-2005-017 345kV (523961 – 51700).
8	FLT_8_1PH	a. Apply 1-phase fault at the Potter bus (523961). b. Clear fault after 4 cycles by removing the line from Potter – GEN-2005-017 345kV (523961 – 51700). c. Wait 30 cycles, and then re-close the line in (b) d. Apply fault for 4 cycles, then trip the line

Cont. Number	Cont. Name	Description
9	FLT_9_3PH	<ul style="list-style-type: none"> a. Apply 3-phase fault at the GEN-2005-017 bus (51700). b. Clear fault after 4 cycles by removing the line from Potter – GEN-2005-017 345kV (523961 – 51700).
10	FLT_10_1PH	<ul style="list-style-type: none"> a. Apply 1-phase fault at the GEN-2005-017 bus (51700). b. Clear fault after 4 cycles by removing the line from Potter – GEN-2005-017 345kV (523961 – 51700). c. Wait 30 cycles, and then re-close the line in (b) d. Apply fault for 4 cycles, then trip the line
11	FLT_11_3PH	<ul style="list-style-type: none"> a. Apply 3-phase fault at the Grapevine bus (523771). b. Clear Fault after 5 cycles by removing line from Grapevine to Stateline 230kV (523771 – 523777). c. Wait 20 cycles, and then re-close line in (b) into the fault. d. Leave fault on for 5 cycles, then trip the line in (b) and remove fault.
12	FLT_12_1PH	<ul style="list-style-type: none"> a. Apply 1-phase fault at the Grapevine bus (523771). b. Clear Fault after 5 cycles by removing line from Grapevine to Stateline 230kV (523771 – 523777). c. Wait 20 cycles, and then re-close line in (b) into the fault. d. Leave fault on for 5 cycles, then trip the line in (b) and remove fault.
13	FLT_13_3PH	<ul style="list-style-type: none"> a. Apply 3-phase fault at the Plant X bus (525481). b. Clear Fault after 5 cycles by removing line from Potter – Plant X 230kV (523959 – 525481). c. Wait 20 cycles, and then re-close line in (b) into the fault. d. Leave fault on for 5 cycles, then trip the line in (b) and remove fault.
14	FLT_14_1PH	<ul style="list-style-type: none"> a. Apply 1-phase fault at the Plant X bus (525481). b. Clear Fault after 5 cycles by removing line from Potter – Plant X 230kV (523959 – 525481). c. Wait 20 cycles, and then re-close line in (b) into the fault. d. Leave fault on for 5 cycles, then trip the line in (b) and remove fault.
15	FLT_15_3PH	<ul style="list-style-type: none"> a. Apply 3-phase fault at the Blackhawk bus (523344). b. Clear Fault after 5 cycles by removing line from Blackhawk – Pringle 115kV (523344 – 523266). c. Wait 20 cycles, and then re-close line in (b) into the fault. d. Leave fault on for 5 cycles, then trip the line in (b) and remove fault.
16	FLT_16_1PH	<ul style="list-style-type: none"> a. Apply 1-phase fault at the Blackhawk bus (523344). b. Clear Fault after 5 cycles by removing line from Blackhawk – Pringle 115kV (523344 – 523266). c. Wait 20 cycles, and then re-close line in (b) into the fault. d. Leave fault on for 5 cycles, then trip the line in (b) and remove fault.
17	FLT_17_3PH	<ul style="list-style-type: none"> a. Apply 3-phase fault at the Potter 230kV bus (523959). b. Clear Fault after 5 cycles by removing line from Potter – Bushland 230kV (523959 – 524267). c. Wait 20 cycles, and then re-close line in (b) into the fault. d. Leave fault on for 5 cycles, then trip the line in (b) and remove fault.



Cont. Number	Cont. Name	Description
18	FLT_18_1PH	a. Apply 1-phase fault at the Potter 230kV bus (523959). c Clear Fault after 5 cycles by removing line from Bushland – Potter 230kV (523959 – 524267). d Wait 20 cycles, and then re-close line in (b) into the fault. e Leave fault on for 5 cycles, then trip the line in (b) and remove fault.

Single line to ground faults were simulated in a manner consistent with currently accepted practices, that is to assume that a single line to ground will cause a voltage drop at the fault location of 60% of nominal.

Control areas monitored:

- Southwest Public Service
- Oklahoma Gas and Electric
- Western Farmers Electric Cooperative
- AEP West, Sunflower Electric Cooperative
- Sunflower Electric Power Corporation
- Mid Kansas Electric Company

Prior queued projects monitored:

- GEN-2002-008
- GEN-2003-013
- GEN-2005-017
- GEN-2005-002
- GEN-2002-009
- GEN-2002-006
- GEN-2004-003
- GEN-2003-020
- GEN-2006-044

3.1. Stability Criteria

Disturbances including three-phase and single-phase to ground faults should not cause synchronous and asynchronous plants to become unstable or disconnect from the transmission grid.

The criterion for synchronous generator stability as defined by NERC is:

“Power system stability is defined as that condition in which the difference of the angular positions of synchronous machine rotor becomes constant following an aperiodic system disturbance.”

Voltage magnitudes and frequencies at terminals of asynchronous generators should not exceed magnitudes and durations that will cause protection elements to operate. Furthermore, the response after the disturbance needs to be studied at the terminals of the machine to insure that there are no sustained oscillations in power output, speed, frequency, etc.

Voltage magnitudes and angles after the disturbance should settle to a constant and reasonable operating level. Frequencies should settle to the nominal 60 Hz power frequency.

3.2. Modeling of Wind Turbine Generators

PSS/E Wind package issue 5.0.0 dated September 2008 was used with PSS/E version 30.3.2. with voltage and frequency relay settings provided by SPP in Table 12.

Table 12: GE 1.5 MW wind turbine generator trip settings

Relay type	Description	Trip setting and time delay	Units
Undervoltage (27-1)	Relay trips if $ V_{bus} <$	0.85	Pu
	for t =	10.0	S
Undervoltage (27-2)	Relay trips if $ V_{bus} <$	0.75	Pu
	for t =	1.0	S
Undervoltage (27-3)	Relay trips if $ V_{bus} <$	0.70	Pu
	for t =	0.625	S
Undervoltage (27-4)	Relay trips if $ V_{bus} <$	0.15	Pu
	for t =	0.625	S
Overvoltage (59-1)	Relay trips if $ V_{bus} >$	1.1	Pu
	for t =	1.0	S
Overvoltage (59-2)	Relay trips if $ V_{bus} >$	1.15	Pu
	for t =	0.1	S
Overvoltage (59-3)	Relay trips if $ V_{bus} >$	1.3	Pu
	for t =	0.02	S
Underfrequency (81U-1)	Relay trips if $F_{bus} <$	57.5	Hz
	for t =	10.0	S
Underfrequency (81U-2)	Relay trips if $F_{bus} <$	56.5	Hz
	for t =	0.02	S
Overfrequency (81O-1)	Relay trips if $F_{bus} >$	61.5	Hz
	for t =	30.0	S
Overfrequency (81U-2)	Relay trips if $F_{bus} >$	62.5	Hz
	for t =	0.02	S

3.3. Pre-Project Simulation Results

Non-disturbance runs of 10 seconds were carried out on Winter Peak 2010 and Summer Peak 2010 base cases to verify proper initialization of dynamic models and to check steady-state conditions. Fault contingency runs for each case in Table 9 with and without the Hitchland – Woodward and Woodward – Northwest lines for summer and winter peak 2010 show that all the control areas will be stable post fault and prior queued wind generation projects will remain connected.

Pre-project study results are summarized in Table 13 for fault contingencies in Table 11.

Table 13: Summary of Pre-Project Transient Stability Analysis Results
With and Without the Hitchland – Woodward and Woodward - Northwest 345 kV lines

Case No.	Description	Summer Peak 2010	Winter Peak 2010
1	FLT_1_3PH	STABLE	STABLE
2	FLT_2_1PH	STABLE	STABLE
3	FLT_3_3PH	STABLE	STABLE
4	FLT_4_1PH	STABLE	STABLE
5	FLT_5_3PH	STABLE	STABLE
6	FLT_6_1PH	STABLE	STABLE
7	FLT_7_3PH	STABLE	STABLE
8	FLT_8_1PH	STABLE	STABLE
9	FLT_9_3PH	STABLE	STABLE
10	FLT_10_1PH	STABLE	STABLE
11	FLT_11_3PH	STABLE	STABLE
12	FLT_12_1PH	STABLE	STABLE
13	FLT_13_3PH	STABLE	STABLE
14	FLT_14_1PH	STABLE	STABLE
15	FLT_15_3PH	STABLE	STABLE
16	FLT_16_1PH	STABLE	STABLE
17	FLT_17_3PH	STABLE	STABLE
18	FLT_18_1PH	STABLE	STABLE

3.4. Post-Project Simulation Results

Non-disturbance runs of 10 seconds were carried out on Winter Peak 2010 and Summer Peak 2010 base cases with the wind project to verify proper initialization of dynamic models and valid power flow cases after the addition of the project.

The simulations assume that the project will consist of standard GE turbines with 9 MVAR of switched capacitor banks at each 34.5 kV collector bus (total of 18 MVAR).

Transient stability results without the Hitchland – Woodward and Woodward - Northwest 345 kV lines are summarized in Table 14. Results indicate that the system will become unstable for FLT_1_3PH and FLT_17_3PH for summer peak and FLT_1_3PH, FLT_2_1PH, and FLT_17_3PH for winter peak. Prior queued project as well as GEN-2006-049 will disconnect on either low voltage or over frequency relay actuation. No SVC or STATCOM

can be used to fix the stability problems. It is an absolute necessity to expand the transmission system. Transient stability results with the Hitchland – Woodward and Woodward - Northwest 345 kV lines in service are summarized in Table 15. Results clearly indicate that for all cases in Table 11, the system retains stability post fault and all wind farms remain connected.

Table 14: Summary of Transient Stability Analysis Results with GEN-2006-049
Without the Hitchland – Woodward and Woodward - Northwest 345 kV lines

Case No.	Description	Summer Peak 2010	Winter Peak 2010
1	FLT_1_3PH	UNSTABLE Present and prior queued wind farms trip off of over frequency	UNSTABLE Present and prior queued wind farms trip off of over frequency
2	FLT_2_1PH	STABLE	UNSTABLE Present and prior queued wind farms trip off of over frequency
3	FLT_3_3PH	STABLE	STABLE
4	FLT_4_1PH	STABLE	STABLE
5	FLT_5_3PH	STABLE	STABLE
6	FLT_6_1PH	STABLE	STABLE
7	FLT_7_3PH	STABLE	STABLE
8	FLT_8_1PH	STABLE	STABLE
9	FLT_9_3PH	STABLE	STABLE
10	FLT_10_1PH	STABLE	STABLE
11	FLT_11_3PH	STABLE	STABLE
12	FLT_12_1PH	STABLE	STABLE
13	FLT_13_3PH	STABLE	STABLE
14	FLT_14_1PH	STABLE	STABLE
15	FLT_15_3PH	STABLE	STABLE
16	FLT_16_1PH	STABLE	STABLE
17	FLT_17_3PH	UNSTABLE GEN-2004-003 trips off on under voltage	UNSTABLE Present and prior queued wind farms trip off of over frequency and under voltage
18	FLT_18_1PH	STABLE	STABLE

Table 15: Summary of Transient Stability Analysis Results with GEN-2006-049
 With the Hitchland – Woodward and Woodward - Northwest 345 kV lines

Case No.	Description	Summer Peak 2010	Winter Peak 2010
1	FLT_1_3PH	STABLE	STABLE
2	FLT_2_1PH	STABLE	STABLE
3	FLT_3_3PH	STABLE	STABLE
4	FLT_4_1PH	STABLE	STABLE
5	FLT_5_3PH	STABLE	STABLE
6	FLT_6_1PH	STABLE	STABLE
7	FLT_7_3PH	STABLE	STABLE
8	FLT_8_1PH	STABLE	STABLE
9	FLT_9_3PH	STABLE	STABLE
10	FLT_10_1PH	STABLE	STABLE
11	FLT_11_3PH	STABLE	STABLE
12	FLT_12_1PH	STABLE	STABLE
13	FLT_13_3PH	STABLE	STABLE
14	FLT_14_1PH	STABLE	STABLE
15	FLT_15_3PH	STABLE	STABLE
16	FLT_16_1PH	STABLE	STABLE
17	FLT_17_3PH	STABLE	STABLE
18	FLT_18_1PH	STABLE	STABLE



4. CONCLUSIONS AND RECOMMENDATIONS

The project can be successfully integrated into the transmission system at the proposed point of interconnection provided the following requirements are met:

- i. A 345 kV Hitchland to Woodward and a single 345 kV line 345 kV line in conjunction with the 345 kV line from Woodward to Northwest is in service ahead of the project's in-service date.
- ii. Total of 18 MVAR of switched capacitor banks are installed at the 34.5 kV collector buses (9 MVAR capacitor banks in each substation) if the standard GE turbines are used.
- iii. GE wind turbine generators are configured to control the voltage at the POI to meet a voltage schedule that can be changed by the system operator.