



***Facility Study
For
Generation Interconnection
Request
GEN-2006-044***

***SPP Tariff Studies
(#GEN-2006-044)***

November 2008

Summary

Pursuant to the tariff and at the request of the Southwest Power Pool (SPP), Xcel Energy performed the following Facility Study to satisfy the Facility Study Agreement executed by the requesting customer and SPP for SPP Generation Interconnection request Gen-2006-044. The request for interconnection was placed with SPP in accordance SPP's Open Access Transmission Tariff, which covers new generation interconnections on SPP's transmission system.

Affected Systems (Sunflower Electric Power Corporation)

Sunflower Electric Power Corporation (SUNC) has been identified in the Impact Study as an Affected System for this Interconnection Request. The latest cost estimates for facilities on the SUNC system have been included in this Facility Study.

If the Interconnection Customer wishes to continue this interconnection request into an Large Generation Interconnection Agreement (LGIA), a requirement of the LGIA will be that the Interconnection Customer will need to enter into a construction agreement with SUNC regarding the facilities identified in this Facility Study as Sunflower Facilities.



**Facilities Study For
Southwest Power Pool (SPP)**
370 MW Wind-Generated Energy Facility
Texas Co., Oklahoma and Hansford Co., Texas
SPP #GEN-2006-044

October 8, 2008
Revised October 17, 2008

Xcel Energy Services, Inc.
Transmission Planning

Executive Summary

[omitted text] in November 2006 (“Interconnection Customer”) requested the interconnection of a wind energy facility located in Texas Co., Oklahoma and partly Hansford Co, Texas to the Southwestern Public Service Company (SPS), a New Mexico Corporation and wholly owned subsidiary of Xcel Energy Inc. 345 kV transmission network. The requested facility has a net capacity of 400 MW. The Interconnection Customer’s facility will connect to the proposed SPS Hitchland Interchange located in Hansford Co., Texas approximately fourteen (14) miles south of Guymon, Oklahoma.

The Southwest Power Pool (SPP) evaluated the request to interconnect the wind farm facility to the SPS transmission system in a System Impact Study (SIS) (GEN-2006-044) completed in August 2008. The interconnection request was studied using two-hundred-sixty-six (266) General Electric wind turbines at 1.5 MW each for a total output of 399 MW. The Impact Study has lowered the queue position to 370 MW or a corresponding number of two-hundred-forty-six (246) General Electric 1.5 MW turbines .The study minimum requirement will consist of adding a 345 kV line terminal at SPS Hitchland Interchange as interconnection point.

SPP instructed SPS to include adding a second 345 kV line parallel with the existing Finney Sub to Holcomb Sub 345 kV transmission line as an alternate to the Hitchland-Mooreland 345 kV line recommended in the SPP SIS study. This is the option that will be considered and estimated for this study.

The SPP SIS study has shown that using the Customer requested General Electric wind turbines with the +/- 90% leading/lagging power factor option, the Customer will not be required to install additional capacitor banks in their facility. The Interconnection Customer’s expected commercial operation date is October 1, 2010 and the requested back-feed date is March 1, 2010.

SPS requires that all construction for this request be in compliance with the latest revision of the Xcel Energy Interconnection Guidelines for Transmission Interconnection Producer-Owned Generation Greater than 20 MW, Version 3.0 dated Dec 31, 2006, and is available at (http://www.xcelenergy.com/XLWEB/CDA/0.3080.1-1-1_16699_24407-1428-0_0_0-0.00.html). This document describes the requirements for connecting new generation to the Xcel Energy transmission systems including technical, protection, commissioning, operation, and maintenance. SPS will also require that the Interconnection Customer be in compliance with all applicable criteria, guidelines, standards, requirements, regulations, and procedures issued by the North American Electric Reliability Corporation (NERC), Southwest Power Pool (SPP), and the Federal Energy Regulatory Commission (FERC) or their successor organizations.

The Interconnection Customer is responsible for the cost of the Interconnection Facilities, and any Direct Assigned Interconnection Facilities; inclusive of all construction required for the 345 kV transmission line from the Interconnection Customer’s substation to the SPS Hitchland Interchange. The Interconnection Customer is also responsible for obtaining any permits and/or Certificate of Convenience and Necessity (CCN) for building their 115 kV and 345kV transmission lines from the Public Utility Commission of Oklahoma and/or Texas.

As for this request (GEN-2006-044), it is anticipated that the entire process of adding the new 345 kV line terminal at Hitchland Interchange for the acceptance of the wind farm facility output and the

construction of the second 345 kV transmission line between Finney and Holcomb, will require approximately 13 months to complete after an Interconnection Agreement is signed and an authorization to proceed is received.

The cost of these upgrades, inclusive of the Interconnection Customer's cost for the interconnection of this wind farm facility, is shown below in Table 1, with the detailed description of the cost shown in Table 3.

Table 1, Cost Summary, Hitchland Interchange

SPS Network Upgrades:	\$5,416,193
Sunflower EC Network Upgrades:	\$4,175,682
Interconnection Facilities ¹ :	\$123,018
Total:	\$9,714,893

¹ This is a direct assigned cost to the Interconnection Customer.

General Description of SPS Facilities²

1. **Construction of New Line Terminal:** See Figure A- 1 Appendix A, for general vicinity location map.
 - 1.1. **Location:** SPS will add a new 345 kV line terminal at the existing SPS Hitchland Interchange. Figure A- 2, Appendix A shows the partial one-line of the Interchange, while Appendix A, Figure A- 3 shows the preliminary partial general arrangement plan view of the interchange.
 - 1.2. **Bus Design:** The new 345 kV line terminal will be added to the existing 345 kV bus at Hitchland Interchange to accommodate the output from the wind energy facility. The existing bus design at Hitchland Interchange will be expanded from three ring breaker/terminal to breaker and a half scheme as shown in the partial preliminary one-line and general arrangement view in Figure A- 2 and Figure A- 3 of Appendix A.
 - 1.3. **Line Terminals:** The conductor will be pulled in at full tension. The substation dead end structures must be capable of 14,000 pounds per conductor (28,000 per bundle). The maximum static tension to be considered is 7,000 pounds per static wire. The dead end towers must be designed for a 15° pull-off angle.
 - 1.4. **Control House:** The existing control house will be utilized to accommodate the new metering, protective relaying and control devices, terminal cabinets, and any fiber-optic cable terminations, etc. for the new 345 kV line breaker terminal.
 - 1.5. **Security Fence:** The existing security fence shall be extended if required when the new branch is added for the new 345 kV line terminal.
 - 1.6. **Ground Grid:** The existing ground grid shall be extended to accommodate the additional bay required for the new line terminal per ANSI/IEEE STD 80-1986, with our standard 4/0 copper ground mesh on 40-foot centers with ground rods and 20-foot centers in corners and loop outside of fence.
 - 1.7. **Site Grading:** Company contractor, per company specifications, will perform any site grading and erosion control to accommodate the new line terminal. Soil compaction shall be not less than 95% of laboratory density as determined by ASTM-D-698.
 - 1.8. **Station Power:** The existing switching station power, provided from the local distribution system, will be utilized.
 - 1.9. **Relay and Protection Scheme:** The protection scheme for the 345 kV line terminals to the interconnection customer's switching station will use pilot relaying schemes on optical fiber installed in the static on the 345 kV transmission lines. Breaker failure relaying, line metering, and SCADA breaker control will also be implemented.

² All modifications to SPS facilities will be owned, maintained and operated by SPS.

- 1.10. **Revenue Metering:** On the proposed SPS Hitchland Interchange 345 kV line terminal to the Interconnection Customer's switching station, an individual billing meter will be installed along with an ION 8400 meter unit, ANSI C12.1 accuracy class 0.2 (3-PT's IEEE C57.13 accuracy class 0.3 and 3 CT's IEEE C57.13 accuracy class 0.15) for full 3 phase 4-wire metering. Also installed for the metering units will be optical 3-PT's and 3-CT's for full 3-phase 4-wire metering. There will be two meters per line terminal: one will be primary and the other will be back up, each will have full 4 quadrant metering. Pulses out of the primary billing meter will be sent via SCADA to the Transmission Owner's Control Center in Amarillo, Texas.
- 1.11. **Disturbance Monitoring Device:** The required input and output points for the new line terminal will be added to the existing disturbance-monitoring equipment (DFR). The DFR is equipped with a GPS time synch clock, is also capable of recording faults, swings, and long term trending. It is used to monitor and record conditions in the substation and on the transmission lines. This equipment has a remote communication capability with a dedicated telephone circuit.
- 1.12. **Remote Terminal Unit (RTU):** The existing RTU will be utilized to accommodate the new 345 kV line terminals at Hitchland Interchange. SPS will provide and install if needed additional RTU cards for metering and telemetry as required by the latest Xcel Energy Interconnection Guidelines. The direct cost will be charged to the Interconnection Customer.
- 1.13. **Communications:** Existing telephone and data circuit at Hitchland Interchange to the Amarillo Control Center will be utilized. *It is the Interconnection Customer's responsibility to make arrangements with the local phone company to provide telephone circuits to the relay communication equipment and disturbance-monitoring equipment at Hitchland Interchange and to their wind farm facility. Prior to any construction the Interconnection Customer is required to contact the SPS substation-engineering department for all details.*

A schematic outlining the proposed communications is provided below:

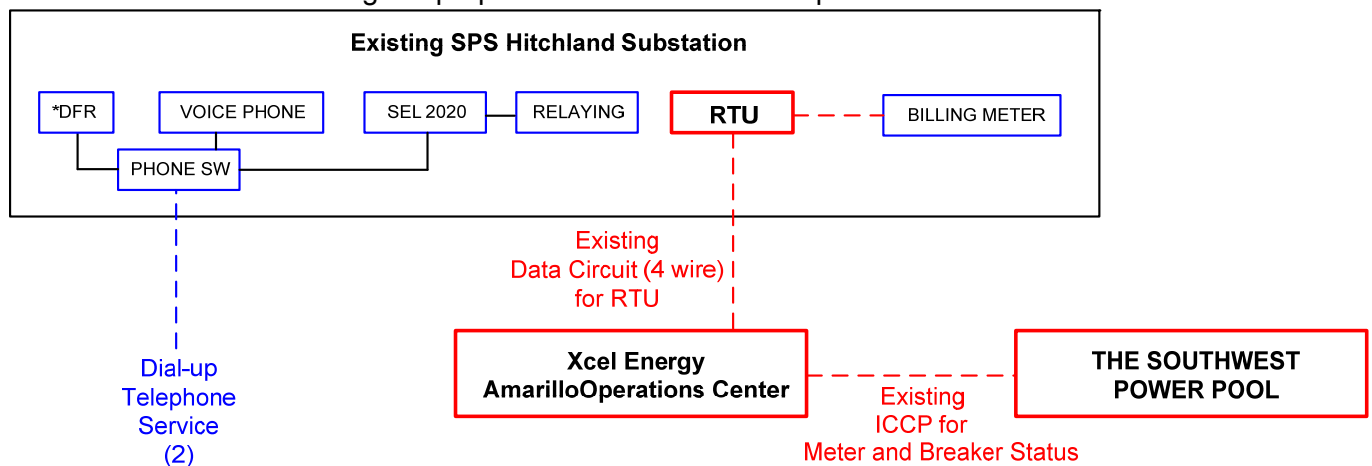

The Interconnection Customer shall be responsible for providing fiber optic communication circuit installed in their overhead transmission line static wire indicated in Section 1.9 from the customer's switching station to Hitchland Interchange control houses. Also customer will be responsible for additional communication relays required at Hitchland Interchange the new wind farm terminal to interrogate protective relays mentioned in Section 1.9.

2. Transmission Work:

- 2.1. SPS will construct, own and operate the second 345 kV transmission line between Finney Interchange and Holcomb Interchange. The Interconnection Customer will construct, own, operate, and maintain the 345 kV transmission line from the Interconnection Customer's switching station to the Interconnection Point at SPS Hitchland Interchange as shown in Appendix A, Figure A- 4. ***The SPS transmission design group prior to any construction by the Interconnection Customer or its contractor on any customer 345 or 115 kV transmission lines, or doing work in close proximity to any SPS transmission line, will require an engineering review of the customer's design. It is the Interconnection Customer's responsibility to initiate the design review in a timely manner before construction of any transmission line begins. If the review has not been made or the design at any of the aforementioned locations is deemed inadequate, the crossing(s) and or termination into the SPS Hitchland Interchange will be delayed until the matters are resolved. SPS will not be held responsible for these delays.***

3. Right-Of-Way and Permits:

- 3.1. **Permitting:** The Texas Public Utility Commission will not require a permit for the construction of a new 345 kV line terminal to receive output from the Customer's wind farm facility at Hitchland Interchange. Also, a Certificate of Convenience and Necessity (CCN) for the second 345 kV transmission line from Finney to Holcomb interchange will be not be required from the State of Kansas Public Utility Commission. The interconnection customer will be responsible for any permitting and right of way of their substation, switching station, the 115 kV transmission lines from their collector substation to their switching station and the 345 kV transmission lines from their Switching to the Interconnection Point at Hitchland Interchange.
4. **Construction Power and Distribution Service:** It is the sole responsibility of the Interconnection Customer to make arrangements for both construction and station power, which may be required for the Interconnection Customer's wind farm facility and switching station. **Additionally, if the Interconnection Customer's substation(s) and/or construction site(s) are located outside of the SPS service area, SPS cannot provide station power (retail distribution service) and the Interconnection Customer needs to make arrangements for distribution service from the local retail provider.**
5. **Project and Operating Concerns:** Close work between the Transmission group, the Interconnection Customer's personnel and local operating groups will be imperative in order to meet any in-service date that has been established.

6. **Fault Current Study:** The available fault current at the interconnection location, without any contribution from the wind farm facilities, is shown in Table 2 below.

Table 2, - Available fault current at Point of Interconnection Location

Short Circuit Current Availability at Hitchland Interchange without contribution from GEN 2006-044				
Fault Location	Fault Current (Amps)		Impedance (Ω)	
	Line-to-Ground	3-Phase	Z^+	Z^0
345 kV Bus	3,350	3,550	4.39+j55.817	6.979+j66.024

Estimated Construction Costs

The projects required for the interconnection of this 370 MW Wind Farm facility consist of the projects summarized in the table below.

Table 3, Required Interconnection Projects³

Project	Description	Estimate
	SPS Network Upgrades	
1	New 345 kV Line Terminal at Finney End ⁴	\$1,689,157
2	Transmission Line Work and ROW ⁵ : Second Finney-Holcomb 345 kV Line	\$435,000
3	345 kV Line Terminal for Wind Farm Facility GEN 2006-044	\$3,292,036
	Subtotal:	\$5,416,193
	Sunflower Electric Network Upgrades	
4	New 345 kV Line Terminal at Holcomb End ⁶	\$4,175,682
	Subtotal:	\$4,175,682
	Interconnection Facilities (at the Interconnection Customer's expense)	
5	Communications ⁷	\$ See <i>footnote</i>
6	345 kV Disconnect Switch	\$ 95,818
7	Revenue metering	\$ 8,075
8	345 kV Line arrestors	\$ 19,125
	Subtotal:	\$123,018
	Total Cost:	\$9,714,893

³ The cost estimates are 2008 dollars with an accuracy level of ±10% except as noted, with AFUDC added.

⁴ Assumptions at Finney Sub: There will not be any land issues and that the current 3-breaker ring can be expanded to a 4-breaker ring.

⁵ Transmission work cost estimate has an accuracy level of ±20% because of unknown Right of Way (ROW) information.

⁶ Sunflower Electric through SPP provided cost estimate and will build the terminal and therefore estimate accuracy level of ±10% will not be SPS's responsibility.

⁷ It is the Requester's responsibility to provide both the data circuit and both dial-up telephone circuits, see Section 1.13.

Engineering and Construction:

An engineering and construction schedule for the installation of the 345 kV line terminal is depicted below and is estimated at approximately 13 months. The schedule is shown for project duration purposes only and other factors associated with clearances, equipment delays and work schedules could cause additional delays. The schedule below is applicable after all required agreements are signed, CCN are issued, and internal approvals are granted.

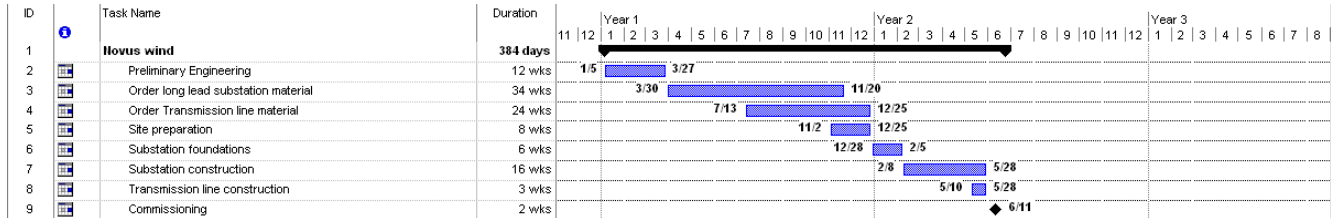

All additional cost for work not identified in this study is the sole responsibility of the Interconnection Customer unless other arrangements are made.

Appendix A



Figure A- 1 Approximate location of proposed Wind Farm Facility

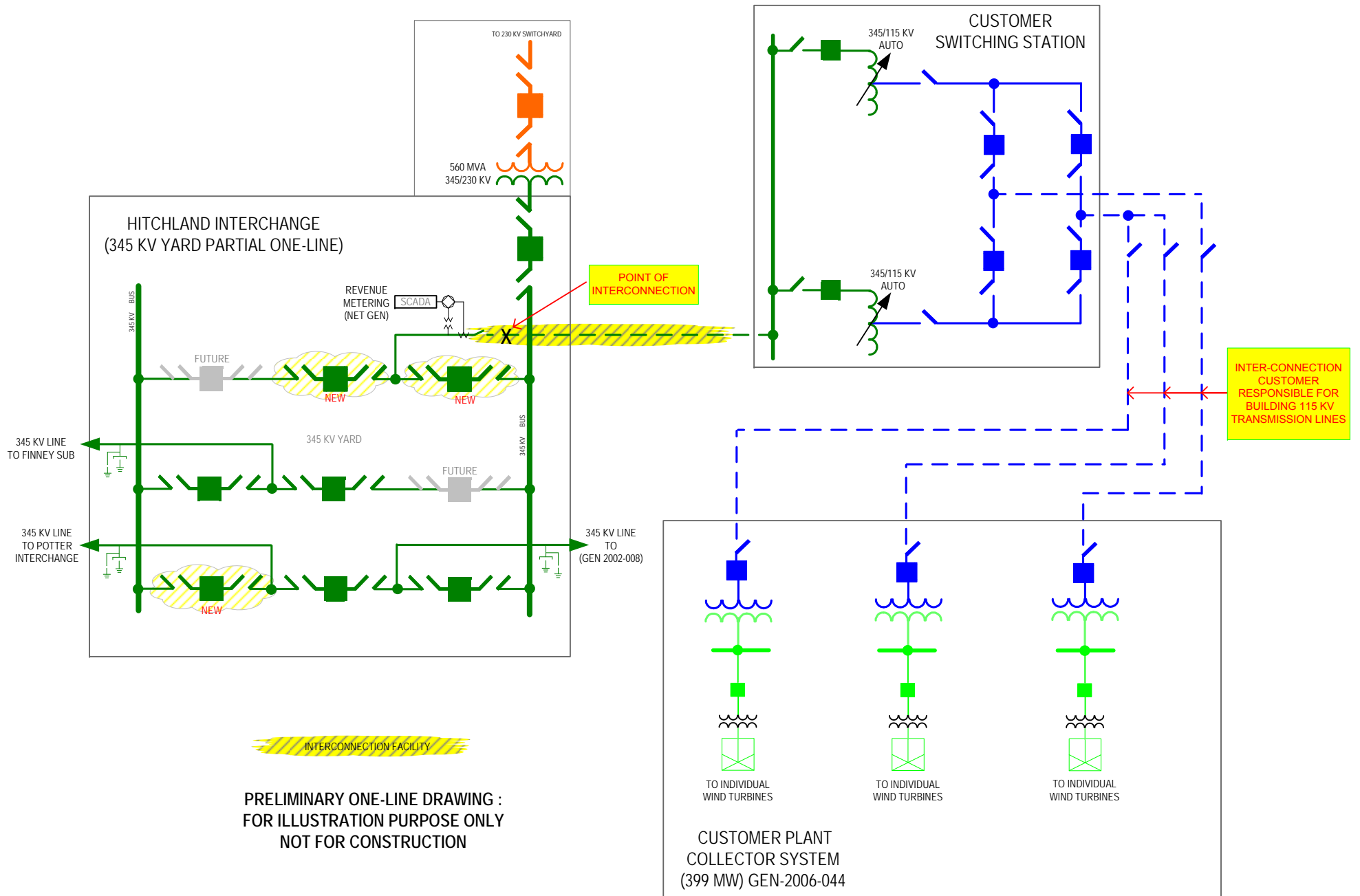

Figure A- 2 One-line Diagram of Hitchland Interchange to Customer Interconnection Facility

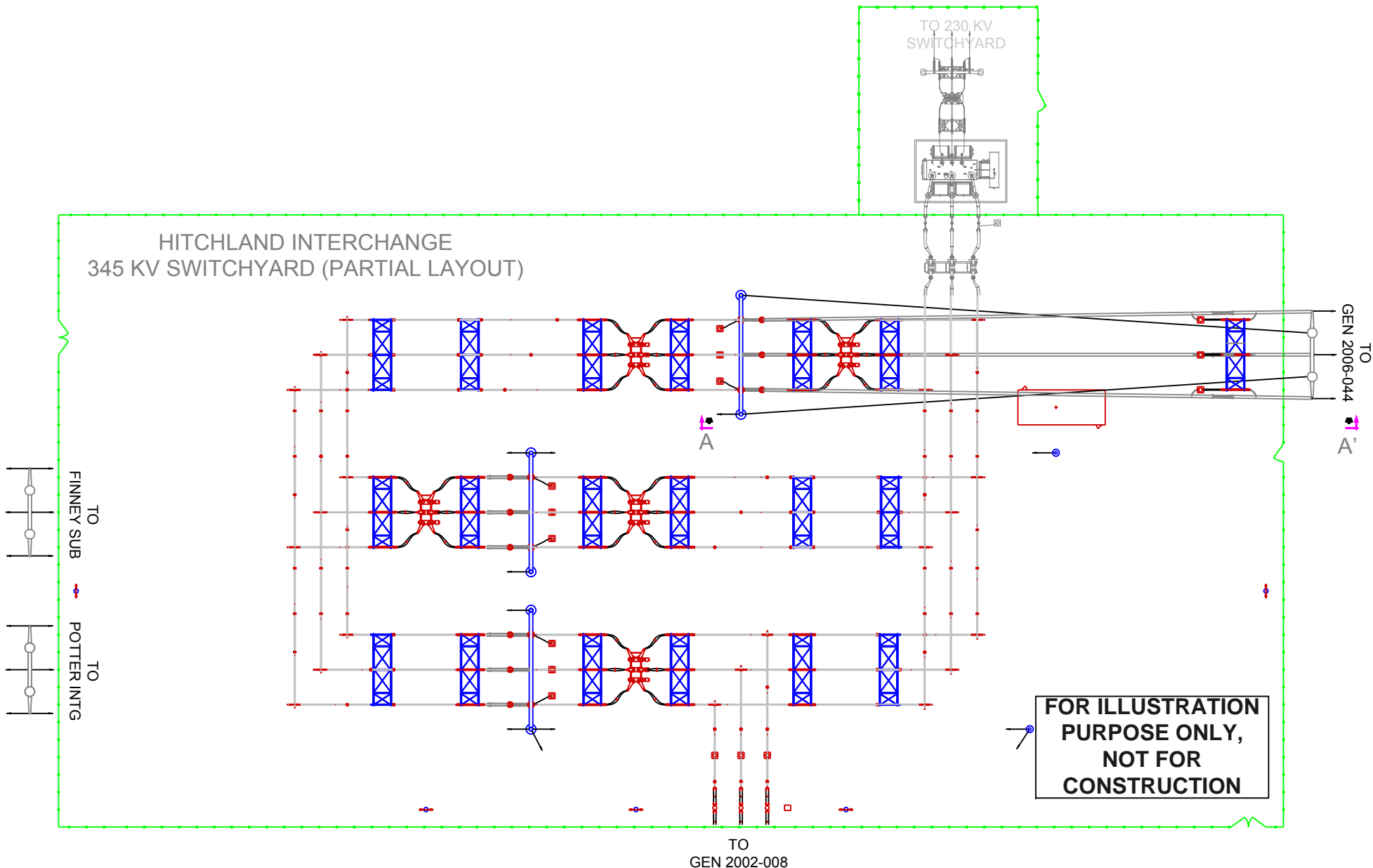

Figure A- 3 Hitchland Interchange Interconnection Facility Preliminary Plan View

**NOTE: CUSTOMER SHALL
PROVIDE ALL MATERIAL
FOR DEAD ENDING PHASES
AND STATIC TO 345 kV
DEAD END TOWER.**

Customer's Responsibility

