



GEN-2006-044N02
Impact Restudy

SPP Generation
Interconnection Studies

GEN-2006-044N02

February 2011

Executive Summary

This report contains the findings of a restudy of GEN-2006-044N02. The GEN-2006-044N02 interconnection request was studied as part of the DISIS-2010-001 Definitive Impact Study, Cluster Group #9, which was originally posted in July 2010. A subsequent restudy was posted 7/30/2010. The original report showed that GEN-2006-044N02 will not require dynamic reactive compensation. With the power factor requirements, and all network upgrades in service, all interconnection request in Group 9 will meet FERC Order #661A low voltage ride through (LVRT) requirements and the transmission system will remain stable. The final PF requirements of the original report at the point of interconnection were 1.0 (Lagging) and 0.982 (Leading).

This restudy was performed solely to evaluate the effects of a turbine manufacturer change of switching wind turbine manufacturers from GE (1.5MW) for 100.5MW to GE (1.6MW) for 99.2MW. This study looked at interconnection at Columbus – Fort Randall 230kV with and interconnection injection of 99.2MW. The restudy results for the final PF requirements at the point of interconnection are 1.0 (Lagging) to 0.971 (Leading) with no need for dynamic reactive compensation in addition to the wind turbine generators.

The findings of the restudy show that for no stability problems were found during summer or winter peak conditions due to the addition of these generators.

Power factor requirements were determined as shown in Table 2-1 of the report below. However, any change in wind turbine model or controls could change the results.

With the assumptions outlined in this report, GEN-2006-044N02 should be able to reliably connect to the SPP transmission grid once all required network upgrades listed in DISIS-2010-001 are placed in service.

Nothing in this study should be construed as a guarantee of transmission service. If the customer wishes to sell power from the facility, a separate request for transmission service shall be requested on Southwest Power Pool's OASIS by the Customer.



Pterra Consulting

Technical Report R103-11

GEN-2006-044N02

Impact Re-Study - Final Report



Submitted to

Southwest Power Pool

January 2011

This page intentionally left blank



Contents

Section 1. Introduction.....	2
1.1. Project Overview	2
1.2. Objectives	3
Section 2. Power Factor Analysis	4
2.1. Methodology	4
2.2. Analysis	4
2.3. Conclusions	7
Section 3. Stability Analysis	8
3.1. Assumptions	8
3.2. Faults Simulated	8
3.3. Simulation Results.....	12
Section 4. Conclusions	13

This page intentionally left blank



Executive Summary

This report presents the results of GEN-2006-044N02 (the "Project") impact re-study comprising of power factor and stability analyses. The Project has a nominal 99.2 MW maximum rating studied using GE 1.6 MW wind turbine generators ("WTGs"). The Point of Interconnection ("POI") is the Columbus-Fort Randall 230 kV line.

The analysis was conducted through the Southwest Power Pool ("SPP") Tariff. Power factor analysis and transient stability simulations were conducted with the Project in service at full output of 99.2 MW.

Two base cases, 2011 summer and winter conditions, each comprising of a power flow and corresponding dynamics database, were provided by SPP. The project plant in the provided power flow model was updated to reflect data for GE 1.6 MW wind turbine generator based on instructions from SPP.

Power Factor Test

The results of the power factor analysis showed that with the MVAR capability of the GE 1.6 MW WTG and without reactive compensation, the power factor at the POI would be from 0.971 lag to 0.993 lag in summer and 0.973 lag to 0.999 lag in winter.

Stability Simulations

Forty-three (43) faults were considered for transient stability simulations which included 3-phase faults as well as 1-phase-to-ground faults at the locations defined by SPP. The results of the simulations showed neither angular nor voltage instability problems for the forty-three faults. The study finds that the interconnection of the proposed 99.2 MW Project does not impact stability performance of the SPP system for the faults tested on the supplied base cases.

Section 1. Introduction

1.1. Project Overview

This report presents the results of the the proposed interconnection GEN-2006-044N02 (the "Project") impact re-study comprising of power factor and stability analyses . The Project has a nominal 99.2 MW maximum rating studied using GE 1.6 MW wind turbine generators ("WTGs"). The Point of Interconnection ("POI") is the Columbus-Fort Randall 230 kV line. Figure 1-1 shows the interconnection diagram of the Project to SPP's 230 kV system as modeled in the power flow cases.

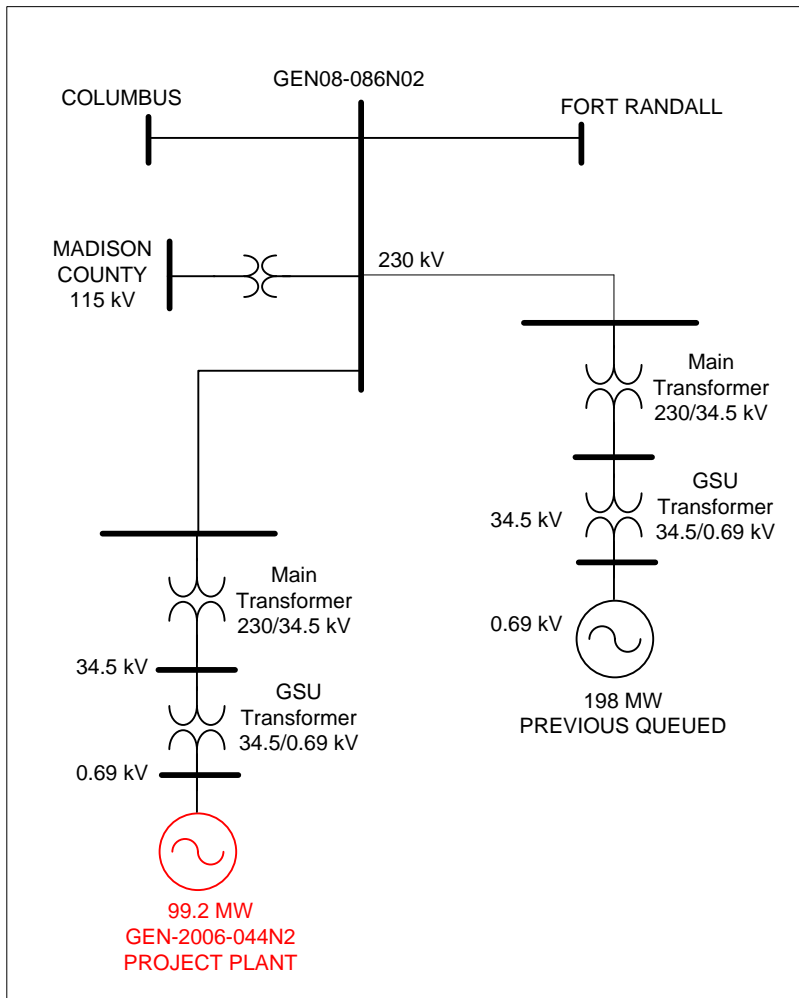

Figure 1-1 Power Flow Model for GEN-2006-044N02

Table 1-1 shows the list of previous queued projects modeled in the base cases.

Table 1-1 List of Prior Queued Projects

Request	Size (MW)	Wind Turbine Model	Point of Interconnection
GEN-2006-020N	42	Vestas 3.0 MW	Bloomfield 115kV (640084)
GEN-2006-038N019	80	GE 1.5 MW	Petersburg 115kV (640318)
GEN-2007-011N08	81	Vestas 3.0 MW	Bloomfield 115kV (640084)
GEN-2006-037N1	75	GE 1.5 MW	Broken Bow 115kV (640089)
GEN-2003-021N	75	Vestas V82 1.65 MW	Ainsworth 115kV (640050)
GEN-2004-005N	30	GE 1.5 MW	St Francis 115kV (640351)
GEN-2006-038N005	80	CIMTR	Broken Bow (640089)
GEN-2006-044N	40.5	GE 1.5 MW	Tap Neligh (640293) – Petersburg (640318) 115kV. (Bus 570644)
GEN-2007-011N06	75	G.E. 1.5 MW	Petersburg 115kV (640318)
GEN-2007-011N09	75	GE 1.5 MW	Bloomfield 115kV (640084)
GEN-2008-086N02	200	GE 1.5 MW	Columbus (640133) – Ft Randall (652509) 230kV. Same POI as GEN-2010-010
GEN-2010-010	100.5	GE 1.5 MW	Columbus (640133) – Ft Randall (652509) 230kV. (Bus 570886)

1.2. Objectives

The objectives of the study are to conduct power factor analysis and to determine the impact on the system stability of interconnecting a proposed 99.2 MW wind farm to SPP's 230 kV transmission system.

Section 2. Power Factor Analysis

2.1. Methodology

Power factor analysis was conducted for the Project using a methodology which is summarized as follows:

1. Turn off the Project wind farm as modeled (as well as previous queued projects at the same point of interconnection). Replace the wind farms by a generator at the high side bus with the MW of the wind farms and no VAR capability.
2. Model a VAR generator at the wind farm's substation high voltage bus. The VAR generator is set to hold a voltage schedule at the POI consistent with the voltage schedule in the provided power flow cases for summer and winter or 1.0 p.u. voltage, whichever is higher.
3. Conduct steady state contingency analysis to determine the power factor necessary at the POI for each contingency.
4. According to the contingency analysis results, determine whether capacitors are required for the Project or not.
5. If the required power factor at the POI is beyond the capability of the studied wind turbines, capacitor banks are considered. The preference is to locate the capacitance banks on the 34.5 kV customer side. Factors to sizing capacitor banks include:
 - 5.1. The ability of the wind farm to meet FERC Order 661A (low voltage ride through) with and without capacitor banks.
 - 5.2. The ability of the wind farm to meet FERC Order 661A (wind farm recovery to pre-fault voltage).
 - 5.3. If wind farms trips on high voltage, power factor lower than unity may be required.

2.2. Analysis

The 99.2 MW Project wind farm and the 198 MW previous queued project (GEN-2008-086N02) connected to the same POI in the provided power flow cases were turned off. A 297.2 MW generator equivalent to the combined capacities of the two plants with no VAR capability was modeled at the Project's 230 kV bus. A VAR generator was also modeled at the same bus and was set to hold a voltage of 1.02 p.u at the POI consistent with the voltage schedule in the provided power flow cases.

Contingency analysis was run for all the specified contingencies. Results show that the VAR generator absorbs reactive power in all the contingencies as summarized in Table 2-1. The highest values obtained are 73.3 and 69.9 MVAR for the summer and winter cases, respectively, both due to the outage of Madison 230/115 kV transformer.

Table 2-1 VAR Generator Output in Summer and Winter Peak Cases

CASE	CONTINGENCY	POWER FACTOR		MW @ POI	VARGEN MVAR
SP	BASE CASE	0.975	Lag	297.2	-67.7
	ALBION (640054)-PETERSBURG (640318) 115KV LINE	0.985	Lag	297.2	-51.8
	ALBION (640054)-GENOA (640181) 115KV LINE	0.976	Lag	297.2	-66.2
	ALBION (640054)-SPALDING (640347) 115KV LINE	0.976	Lag	297.2	-66.8
	CLEARWATER (640113)-NELIGH (640293) 115KV LINE	0.973	Lag	297.2	-69.9
	COUNTY LINE (640115)-NELIGH (640293) 115KV LINE	0.976	Lag	297.2	-66.5
	CREIGHTON (640149)-NELIGH (640293) 115KV LINE	0.975	Lag	297.2	-68.4
	BLOOMFIELD (640084)-GAVINS (652511) 115KV LINE	0.976	Lag	297.2	-65.6
	HARTINGTON (640212)-GAVINS (652511) 115KV LINE	0.976	Lag	297.2	-65.6
	SHELL CREEK (640343)-COLUMBUS (640133) 230KV LINE	0.979	Lag	297.2	-62.2
	COLUMBUS WEST (640131)-COLUMBUS (640133) 230KV LINE	0.972	Lag	297.2	-71.6
	EAST COLUMBUS (640126)-COLUMBUS (640133) 230KV LINE	0.976	Lag	297.2	-66.4
	GEN-2008-086N02 (570886)-COLUMBUS (640133) 230KV LINE	0.993	Lag	297.2	-35.8
	FORT RANDALL (652509)-UTICA JCT (652526) 230KV LINE	0.983	Lag	297.2	-54.9
	FORT RANDALL (652509)-LAKE PLATT (652516) 230KV LINE	0.973	Lag	297.2	-70.2
	FORT RANDALL (652509)-SIOUX CITY (652565) 230KV LINE	0.982	Lag	297.2	-56.8
	KELLY 230/115 KV TRANSFORMER (640134)	0.976	Lag	297.2	-66.3
	BLOOMFIELD (640084)-GAVINS POINT (652511) 115 KV LINE	0.976	Lag	297.2	-65.6
	CREIGHTON (640149)-NELIGH (640293) 115 KV LINE	0.975	Lag	297.2	-68.4
	GAVINS POINT (652511)-HARTINGTON (640212) 115 KV LINE	0.976	Lag	297.2	-65.6
	NELIGH (640293) - COUNTY LINE (640115)	0.976	Lag	297.2	-66.5
	ALBION (640054)-GENOA (640181) 115 KV LINE	0.976	Lag	297.2	-66.2
	COLUMBUS (640133)-COLUMBUS WEST (640131) 230 KV LINE	0.972	Lag	297.2	-71.6
	GAVINS PT-BLOOMFIELD 115 KV LINE W/ PRIOR OUTAGE OF NELIGH-COUNTY 115 KV LINE	0.976	Lag	297.2	-65.6
	ALBION-PETERSBURG 115 KV LINE W/ PRIOR OUTAGE OF NELIGH-COUNTY 115 KV LINE	0.985	Lag	297.2	-51.8
	HOSKINS 230/115 KV AUTOTRANSFORMER	0.975	Lag	297.2	-68.0
	HOSKINS 345/115 KV AUTOTRANSFORMER	0.979	Lag	297.2	-62.4
	FT. RANDALL 230/115 KV AUTOTRANSFORMER	0.975	Lag	297.2	-67.6
	MADISON COUNTY 230/115 KV AUTOTRANSFORMER	0.971	Lag	297.2	-73.3
	SHELL CREEK (640342)-HOSKINS (640226) 345KV LINE	0.978	Lag	297.2	-63.9
	RAUN (635200)-HOSKINS (640226) 345KV LINE	0.982	Lag	297.2	-57.8
	BELDEN (640080)-BLOOMFIELD (640084) 115KV LINE	0.977	Lag	297.2	-65.2
	MADISON (640263)-CRESTON (640151) 115KV LINE	0.974	Lag	297.2	-69.4
	MADISON COUNTY (578001)-PETERSBURG (640318) 115KV LINE	0.978	Lag	297.2	-62.9
	BROKEN BOW (640089)-C. CREEK (640094) 115KV LINE	0.975	Lag	297.2	-67.4
	BROKEN BOW (640089)-CALAWAY (640098) 115KV LINE	0.975	Lag	297.2	-67.7
	BROKEN BOW (640089)-LOUP CITY (640259) 115KV LINE	0.976	Lag	297.2	-67.0
	BELDEN (640080)-HOSKINS (640228) 115KV LINE	0.974	Lag	297.2	-68.5
	BELDEN (640080)-TWIN CHURCH (640387) 115KV LINE	0.976	Lag	297.2	-65.7
	TWIN CHURCH (640386)-SIOUX CITY (652565) 230KV LINE	0.981	Lag	297.2	-58.0
	HOSKINS (640226/640227) 345/230KV TRANSFORMER	0.976	Lag	297.2	-65.8
CROOKED CREEK (640093/640094) 230/115KV TRANSFORMER	0.975	Lag	297.2	-67.4	
N.PLATT (640287/640286) 115/230KV TRANSFORMER	0.975	Lag	297.2	-67.8	
GEN-2008-086N02 (570886)-FT RANDALL (652509) 230KV LINE	0.992	Lag	297.2	-36.6	

CASE	CONTINGENCY	POWER FACTOR		MW @ POI	VARGEN MVAR
WP	BASE CASE	0.990	Lag	297.2	-43.4
	ALBION (640054)-PETERSBURG (640318) 115KV LINE	0.992	Lag	297.2	-37.1
	ALBION (640054)-GENOA (640181) 115KV LINE	0.991	Lag	297.2	-39.9
	ALBION (640054)-SPALDING (640347) 115KV LINE	0.990	Lag	297.2	-42.4
	CLEARWATER (640113)-NELIGH (640293) 115KV LINE	0.990	Lag	297.2	-42.7
	COUNTY LINE (640115)-NELIGH (640293) 115KV LINE	0.990	Lag	297.2	-41.9
	CREIGHTON (640149)-NELIGH (640293) 115KV LINE	0.989	Lag	297.2	-44.1
	BLOOMFIELD (640084)-GAVINS (652511) 115KV LINE	0.991	Lag	297.2	-40.1
	HARTINGTON (640212)-GAVINS (652511) 115KV LINE	0.990	Lag	297.2	-41.6
	SHELL CREEK (640343)-COLUMBUS (640133) 230KV LINE	0.993	Lag	297.2	-36.6
	COLUMBUS WEST (640131)-COLUMBUS (640133) 230KV LINE	0.990	Lag	297.2	-42.9
	EAST COLUMBUS (640126)-COLUMBUS (640133) 230KV LINE	0.990	Lag	297.2	-42.2
	GEN-2008-086N02 (570886)-COLUMBUS (640133) 230KV LINE	0.998	Lag	297.2	-19.5
	FORT RANDALL (652509)-UTICA JCT (652526) 230KV LINE	0.994	Lag	297.2	-32.0
	FORT RANDALL (652509)-LAKE PLATT (652516) 230KV LINE	0.989	Lag	297.2	-45.0
	FORT RANDALL (652509)-SIOUX CITY (652565) 230KV LINE	0.993	Lag	297.2	-34.3
	KELLY 230/115 KV TRANSFORMER (640134)	0.989	Lag	297.2	-43.8
	BLOOMFIELD (640084)-GAVINS POINT (652511) 115 KV LINE	0.991	Lag	297.2	-40.1
	CREIGHTON (640149)-NELIGH (640293) 115 KV LINE	0.989	Lag	297.2	-44.1
	GAVINS POINT (652511)-HARTINGTON (640212) 115 KV LINE	0.990	Lag	297.2	-41.6
	NELIGH (640293) - COUNTY LINE (640115)	0.990	Lag	297.2	-41.9
	ALBION (640054)-GENOA (640181) 115 KV LINE	0.991	Lag	297.2	-39.9
	COLUMBUS (640133)-COLUMBUS WEST (640131) 230 KV LINE	0.990	Lag	297.2	-42.9
	GAVINS PT-BLOOMFIELD 115 KV LINE W/ PRIOR OUTAGE OF NELIGH-COUNTY 115 KV LINE	0.991	Lag	297.2	-40.1
	ALBION-PETERSBURG 115 KV LINE W/ PRIOR OUTAGE OF NELIGH-COUNTY 115 KV LINE	0.992	Lag	297.2	-37.1
	HOSKINS 230/115 KV AUTOTRANSFORMER	0.990	Lag	297.2	-42.8
	HOSKINS 345/115 KV AUTOTRANSFORMER	0.991	Lag	297.2	-39.9
	FT. RANDALL 230/115 KV AUTOTRANSFORMER	0.990	Lag	297.2	-43.3
	MADISON COUNTY 230/115 KV AUTOTRANSFORMER	0.973	Lag	297.2	-69.9
	SHELL CREEK (640342)-HOSKINS (640226) 345KV LINE	0.990	Lag	297.2	-42.8
	RAUN (635200)-HOSKINS (640226) 345KV LINE	0.993	Lag	297.2	-35.4
	BELDEN (640080)-BLOOMFIELD (640084) 115KV LINE	0.991	Lag	297.2	-40.8
	MADISON (640263)-CRESTON (640151) 115KV LINE	0.990	Lag	297.2	-43.2
	MADISON COUNTY (578001)-PETERSBURG (640318) 115KV LINE	0.990	Lag	297.2	-43.2
	BROKEN BOW (640089)-C. CREEK (640094) 115KV LINE	0.990	Lag	297.2	-42.2
	BROKEN BOW (640089)-CALAWAY (640098) 115KV LINE	0.990	Lag	297.2	-43.3
	BROKEN BOW (640089)-LOUP CITY (640259) 115KV LINE	0.988	Lag	297.2	-46.0
	BELDEN (640080)-HOSKINS (640228) 115KV LINE	0.989	Lag	297.2	-43.5
	BELDEN (640080)-TWIN CHURCH (640387) 115KV LINE	0.991	Lag	297.2	-41.2
	TWIN CHURCH (640386)-SIOUX CITY (652565) 230KV LINE	0.992	Lag	297.2	-38.4
	HOSKINS (640226/640227) 345/230KV TRANSFORMER	0.990	Lag	297.2	-41.4
	CROOKED CREEK (640093/640094) 230/115KV TRANSFORMER	0.990	Lag	297.2	-42.2
	N.PLATT (640287/640286) 115/230KV TRANSFORMER	0.989	Lag	297.2	-43.5
GEN-2008-086N02 (570886)-FT RANDALL (652509) 230KV LINE	0.999	Lag	297.2	-5.1	

2.3. Conclusions

The results of the power factor analysis showed that with the MVAR capability of the GE 1.6 MW WTG and without reactive compensation, the power factor at the POI would be from 0.971 lag to 0.993 lag in summer and 0.973 lag to 0.999 lag in winter.

Section 3. Stability Analysis

3.1. Assumptions

The following assumptions were adopted for the dynamic simulations:

1. Constant maximum and uniform wind speed for the entire period of study.
2. Wind turbine control models with their default values.
3. Under/over voltage/frequency protection use manufacturer settings.

3.2. Faults Simulated

Forty-three (43) faults were considered for the transient stability simulations which included three phase faults as well as single phase line faults at the locations defined by SPP. Single-phase line faults were simulated by applying a fault impedance to the positive sequence network at the fault location to represent the effect of the negative and zero sequence networks on the positive sequence network. The fault impedance was computed to give a positive sequence voltage at the specified fault location of approximately 60% of pre-fault voltage. This method is in agreement with SPP current practice. The previous queued projects shown in Table 1-1 and units in areas 531, 534, 536, 540, 541, 640, 645, 650 and 652 were monitored in the simulations. Table 3-1 shows the list of simulated contingencies with corresponding clearing times.

Table 3-1 List of Simulated Faults

No.	Name	Description
1	FLT01-3PH	3 phase fault on the Albion (640054) to Petersburg (640318) 115kV line, near Petersburg.
		a. Apply fault at the Petersburg 115kV bus.
		b. Clear fault after 6.5 cycles by tripping the faulted line.
2	FLT02-3PH	3 phase fault on the Albion (640054) to Genoa (640181) 115kV line, near Albion.
		a. Apply fault at the Albion 115kV bus.
		b. Clear fault after 6.5 cycles by tripping the faulted line.
3	FLT03-3PH	3 phase fault on the Albion (640054) to Spalding (640347) 115kV line, near Albion.
		a. Apply fault at the Albion 115kV bus.
		b. Clear fault after 6.5 cycles by tripping the faulted line.
4	FLT04-3PH	3 phase fault on the Clearwater (640113) to Neligh (640293) 115kV line, near Neligh.
		a. Apply fault at the Neligh 115kVbus.
		b. Clear fault after 6.5 cycles by tripping the faulted lines (Neligh-Clearwater-O'Neill 115 kV).
5	FLT05-3PH	3 phase fault on the County Line (640115) to Neligh (640293) 115kV line, near Neligh.
		a. Apply fault at the Neligh 115kVbus.
		b. Clear fault after 6.5 cycles by tripping the faulted lines (Neligh-CountyLine-BattleCreek-NorthNorfolk 115 kV).
6	FLT06-3PH	3 phase fault on the Creighton (640149) to Neligh (640293) 115kV line, near Neligh.

No.	Name	Description
		a. Apply fault at the Neligh 115kVbus. b. Clear fault after 6.5 cycles by tripping the faulted line.
7	FLT07-3PH	3 phase fault on the Bloomfield (640084) to Gavins (652511) 115kV line, near Bloomfield. a. Apply fault at the Bloomfield 115kV bus. b. Clear fault after 6.5 cycles by tripping the faulted line.
8	FLT08-3PH	3 phase fault on the Hartington (640212) to Gavins (652511) 115kV line, near Hartington. a. Apply fault at the Gavins Point 115kV bus. b. Clear fault after 6.5 cycles by tripping the faulted line.
9	FLT09-3PH	3 phase fault on the Shell Creek (640343) to Columbus (640133) 230kV line, near Columbus a. Apply fault at the Columbus 230kV bus. b. Clear fault after 6.0 cycles by tripping the faulted line.
10	FLT10-3PH	3 phase fault on the Columbus West (640131) to Columbus (640133) 230kV line, near Columbus a. Apply fault at the Columbus 230kV bus. b. Clear fault after 6.0 cycles by tripping the faulted line.
11	FLT11-3PH	3 phase fault on the East Columbus (640126) to Columbus (640133) 230kV line, near Columbus a. Apply fault at the Columbus 230kV bus. b. Clear fault after 6.0 cycles by tripping the faulted line.
12	FLT12-3PH	3 phase fault on the GEN-2008-086N02 (570886) to Columbus (640133) 230kV line, near GEN-2008-086N02 a. Apply fault at the GEN-2008-086N02 230V bus. b. Clear fault after 6.0 cycles by tripping the faulted line.
13	FLT13-3PH	3 phase fault on the Fort Randall (652509) to Utica Jct (652526) 230kV line, near Fort Randall a. Apply fault at the Fort Randall 230V bus. b. Clear fault after 6.0 cycles by tripping the faulted line.
14	FLT14-3PH	3 phase fault on the Fort Randall (652509) to Lake Platt (652516) 230kV line, near Fort Randall a. Apply fault at the Fort Randal 230V bus. b. Clear fault after 6.0 cycles by tripping the faulted line.
15	FLT15-3PH	3 phase fault on the Fort Randall (652509) to Sioux City (652565) 230kV line, near Fort Randall a. Apply fault at the Fort Randal 230V bus. b. Clear fault after 6.0 cycles by tripping the faulted line.
16	FLT16-3PH	3 phase fault on the Kelly 230/115 kV auto at the 115kV (640134) a. Apply fault at the Kelly 115kV bus. b. Clear fault after 5.5 cycles by tripping autotransformer.
17	FLT17-1PH	SLG fault on Bloomfield (640084) – Gavins Point (652511) 115 kV line, near Bloomfield. Stuck breaker at Gavins. a. Apply fault at Bloomfield 115 kV bus.

No.	Name	Description
		b. Clear Bloomfield end of line at 5.5 cycles. Leave fault on end of open-ended line from Gavins Point.
		c. Clear Gavins Point 115 kV bus and fault at 18.0 cycles.
18	FLT18-1PH	SLG fault on Creighton (640149) – Neligh (640293) 115 kV line, near Creighton. Stuck breaker at Creighton.
		a. Apply fault at Creighton 115 kV bus.
		b. Clear Neligh end of line at 6.5 cycles. Leave fault on open-ended line from Creighton.
		c. Clear Creighton 115 kV bus and fault at 18.0 cycles.
19	FLT19-1PH	SLG fault on Gavins Point (652511) – Hartington (640212) 115 kV line, near Gavins Point. Stuck breaker at Gavins Point.
		a. Apply fault at Gavins Point 115 kV bus.
		b. Clear Hartington end of line at 6.5 cycles. Leave fault on open-ended line from Gavins Point.
		c. Clear Gavins Point 115 kV bus and fault at 18.0 cycles.
20	FLT20-1PH	SLG fault on Neligh (640293) - County Line (640115), near Neligh. Stuck PCB at Neligh.
		a. Apply fault at Neligh 115 kV bus.
		b. Clear North Norfolk end of Neligh-County Line-Battle Creek (640072)-North Norfolk (640296) 115 kV line at 6.5 cycles. Leave fault on open-ended line.
		c. Clear Neligh 115 kV bus and fault at 18.0 cycles.
21	FLT21-1PH	SLG fault on Albion (640054) – Genoa (640181) 115 kV line near Albion. Stuck PCB at Albion.
		a. Apply fault on Albion 115 kV bus.
		b. Clear Genoa end of Albion-Genoa 115 kV line at 6.5 cycles. Leave fault on open-ended line.
		c. Clear Albion 115 kV bus and fault at 18.0 cycles.
22	FLT22-1PH	SLG fault on Columbus (640133) – Columbus West (640131) 230 kV line. Stuck PCB at Columbus.
		a. Apply fault on Columbus 230 kV bus.
		b. Clear Columbus West end of line at 6.0 cycles. Leave fault on open-ended line.
		c. Clear Columbus 230 kV bus and fault at 14.5 cycles.
23	FLT23-3PH	3PH fault on Gavins Point (652511) – Bloomfield (640084) 115 kV line with prior outage of Neligh (640293) – County Line (640115) 115 kV.
		a. Prior Outage: Neligh – County Line 115 kV
		b. Apply 3PH fault on Bloomfield 115 kV bus.
		c. Clear fault after 6.5 cycles and trip faulted Gavins Point – Bloomfield 115 kV line.
24	FLT24-3PH	3PH fault on Albion (640054) – Petersburg (640318) 115 kV line with prior outage of Neligh (640293) – County Line (640115) 115 kV.
		a. Prior Outage: Neligh – County Line 115 kV
		b. Apply 3PH fault on Petersburg 115 kV bus.
		c. Clear fault after 6.5 cycles and trip faulted Albion – Petersburg 115 kV line.

No.	Name	Description
25	FLT25-3PH	3 phase fault on the Hoskins 230/115 kV autotransformer at the 115kV (640228)
		a. Apply fault at the Hoskins 115kV bus.
		b. Clear fault after 5.5 cycles by tripping the autotransformer
26	FLT26-3PH	3 phase fault on the Hoskins 345/115 kV autotransformer at the 115kV (640228)
		a. Apply fault at the Hoskins 115kV bus.
		b. Clear fault after 5.5 cycles by tripping the autotransformer
27	FLT27-3PH	3 phase fault on the Ft. Randall 230/115 kV autotransformer at the 115kV (652510)
		a. Apply fault at the Ft. Randall 115kV bus.
		b. Clear fault after 5.5 cycles by tripping the autotransformer
28	FLT28-3PH	3 phase fault on the Madison County 230/115 kV autotransformer at the 115kV (578001)
		a. Apply fault at the Madison County 115kV bus.
		b. Clear fault after 5.5 cycles by tripping the autotransformer
29	FLT29-3PH	3 phase fault on the Shell Creek (640342) to Hoskins (640226) 345kV line, near Hoskins.
		a. Apply fault at the Hoskins 345kV bus.
		b. Clear fault after 4.5 cycles by tripping the faulted line.
30	FLT30-3PH	3 phase fault on the Raun (635200) to Hoskins (640226) 345kV line, near Hoskins.
		a. Apply fault at the Hoskins 345kV bus.
		b. Clear fault after 4.5 cycles by tripping the faulted line.
31	FLT31-3PH	3 phase fault on the Belden (640080) to Bloomfield (640084) 115kV line, near Belden.
		a. Apply fault at the Belden 115kV bus.
		b. Clear fault after 6.5 cycles by tripping the faulted line.
32	FLT32-3PH	3 phase fault on the Madison (640263) to Creston (640151) 115kV line, near Madison.
		a. Apply fault at the Madison 115kV bus.
		b. Clear fault after 6.5 cycles by tripping the faulted line.
33	FLT33-3PH	3 phase fault on the Madison County (578001) to Petersburg (640318) 115kV line, near Madison County.
		a. Apply fault at the Madison County 115kV bus.
		b. Clear fault after 6.5 cycles by tripping the faulted line.
34	FLT34-3PH	3 phase fault on the Broken Bow (640089) to C. Creek (640094) 115kV line, near Broken Bow.
		a. Apply fault at the Broken Bow 115kV bus.
		b. Clear fault after 6.5 cycles by tripping the faulted line.
35	FLT35-3PH	3 phase fault on the Broken Bow (640089) to Calaway (640098) 115kV line, near Broken Bow.
		a. Apply fault at the Broken Bow 115kV bus.
		b. Clear fault after 6.5 cycles by tripping the faulted line.
36	FLT36-3PH	3 phase fault on the Broken Bow (640089) to Loup City (640259) 115kV line, near Broken Bow.
		a. Apply fault at the Broken Bow 115kV bus.

No.	Name	Description
		b. Clear fault after 6.5 cycles by tripping the faulted line.
37	FLT37-3PH	3 phase fault on the Belden (640080) to Hoskins (640228) 115kV line, near Belden
		a. Apply fault at the Belden 115kV bus.
		b. Clear fault after 6.5 cycles by tripping the faulted line.
38	FLT38-3PH	3 phase fault on the Belden (640080) to Twin Church (640387) 115kV line, near Belden
		a. Apply fault at the Belden 115kV bus.
		b. Clear fault after 6.5 cycles by tripping the faulted line.
39	FLT39-3PH	3phase fault on the Twin Church (640386) to Sioux City (652565) 230kv line near Twin Church
		a. Apply fault at Twin Church 230kV bus.
		b. Clear fault after 6.5 cycles by tripping the faulted line.
40	FLT40-3PH	3phase fault on Hoskins (640226/640227) 345/230kV transformer
		a. Apply fault at the 230kV bus.
		b. Clear fault after 5.5 cycles by tripping transformer.
41	FLT41-3PH	3phase fault on Crooked Creek (640093/640094) 230/115kV transformer
		a. Apply fault at the 115kV bus.
		b. Clear fault after 5.5 cycles by tripping the transformer
42	FLT42-3PH	3phase fault on N.Platt (640287/640286) 115/230kV transformer
		a. Apply fault at the 115kV bus.
		b. Clear fault after 5.5 cycles by tripping transformer
43	FLT43-3PH	3 phase fault on the GEN-2008-086N02 (570886) to Ft Randall (652509) 230kV line, near GEN-2008-086N02
		a. Apply fault at the GEN-2008-086N02 230V bus.
		b. Clear fault after 6.0 cycles by tripping the faulted line

Simulations were performed with a 0.1-second steady-state run followed by the appropriate disturbance as described in Table 3-1. Simulations were run for a minimum 10-second duration to confirm proper machine damping.

3.3. Simulation Results

The stability simulations for the forty-three specified test faults did not find any angular or voltage instability problems in the SPP system. The study finds that the interconnection of the proposed 99.2 MW Project does not impact the stability performance of the SPP system for the faults tested on the supplied base cases.

Section 4. Conclusions

The findings of GEN-2006-044N02 impact re-study are as follows:

1. The results of the power factor analysis showed that with the MVAR capability of the GE 1.6 MW WTG and without reactive compensation, the power factor at the POI would be from 0.971 lag to 0.993 lag in summer and 0.973 lag to 0.999 lag in winter.
2. The stability simulations for the forty-three (43) specified test faults did not find any angular or voltage instability problems in the SPP system. The study finds that the interconnection of the proposed 99.2 MW Project does not impact the stability performance of the SPP system for the contingencies tested on the supplied base cases.