



***Facility Study for Generation
Interconnection Request
GEN – 2005 – 010***

***SPP Tariff Studies
(#GEN-2005-010)***

May, 2006

Summary

Pursuant to the tariff and at the request of the Southwest Power Pool (SPP), Xcel Energy (Xcel) performed the following Facility Study to satisfy the Facility Study Agreement executed by the requesting customer and SPP for SPP Generation Interconnection request Gen-2005-010. The request for interconnection was placed with SPP in accordance SPP's Open Access Transmission Tariff, which covers new generation interconnections on SPP's transmission system.

In addition to costs detailed in this Facility Study, the Customer is also responsible for installing two (2) 6 MVAR capacitor banks in the Customer substation as detailed in the Impact Study.

With Customer requested Gamesa G87 2.0 MW wind turbines, this request is compliant with FERC Order #661A as detailed in the Impact Study. If the Customer wishes to change turbine manufacturer, a new impact study will be required.



**Facilities Study For
[Omitted Text]**

160 MW Wind-Generated Energy Facility
Bailey County, Texas
SPP #GEN-2005-010

May 16, 2006

Xcel Energy Services, Inc.
Transmission Planning

Executive Summary

[Omitted Text] (“Interconnection Customer”) has requested the connection of a wind energy facility to the Southwestern Public Service Company (SPS) (d/b/a Xcel Energy, Inc.) 230 kV transmission system in the vicinity of the Sand Hills Substation. This facility will connect to a new 3-breaker ring 230 kV switching station located adjacent to SPS’s circuit K-18 approximately 7.3 miles west of Tolk Station and 2½ miles southeast of Muleshoe, Texas. SPS’s switching station will be adjacent to the customer’s Sand Hills Substation. The Southwest Power Pool (SPP) evaluated the request to connect this wind energy facility to the SPS transmission system in a System Impact Study completed in January 2006. This connection request was studied using eighty (80) individual Gamesa G87 2.0 MW wind turbines for a total of 160 MW. The Interconnection Customer’s requested in-service date is December 2007 for commercial operation. This Facilities Study acknowledges the required construction phase of 15 months from the date of final approval.

Xcel Energy will require the Interconnection Customer to construct the Connection Facilities in compliance with the latest revision of the Xcel Energy Interconnection Guidelines for Transmission Interconnection Producer-Owned Generation Greater than 20 MW, Version 2.0 dated Jan. 20, 2004, and is available at http://www.xcelenergy.com/XLWEB/CDA/0,3080,1-1-1_16699_24407-1428-0_0_0-0,00.html. This document describes the requirements for connecting new generation to the Xcel Energy operating company transmission systems including technical, protection, commissioning, operation, and maintenance. Xcel Energy will also require that the Interconnection Customer be in compliance with all applicable criteria, guidelines, standards, requirements, regulations, and procedures issued by the North American Electric Reliability Council, (NERC), Southwest Power Pool (SPP), and Federal Energy Regulatory Commission (FERC) or their successor organizations.

The Interconnection Customer is responsible for the cost of the Interconnection Facilities and any Direct Assigned Interconnection Facilities; inclusive of all construction required for the 230 kV transmission line from the Interconnection Customer’s substation to the switching station.

It is anticipated that the construction of the new switching station, for the acceptance of wind generated electric energy from the Interconnection Customer’s Wind Farm, will require approximately 15 months for completion from the day an interconnection agreement is signed and after all internal approvals, unless prior arrangements have been made. The cost of these upgrades, inclusive of the Interconnection Customer’s cost for the Interconnection Facilities required for the connection of this new wind energy generation facility, is shown below. See [Table 2](#) for a detail description of all the costs.

| Upgrade | Cost |
|---|---------------------|
| Stand-alone Network Upgrade: | \$ 2,271,382 |
| Network Upgrade: | \$ 424,813 |
| Interconnection Facilities ¹ : | \$ 238,204 |
| Total: | \$ 2,934,699 |

¹ Direct Assigned Cost To Requester

Discussion

A new 230 kV switching station is required for the Interconnection of the Customer's wind-generated energy facility and it will be located adjacent to the existing 230 kV transmission line and the Sand Hills Substation. The new switching station will consist of three 230 kV breakers in a ring bus configuration. The existing transmission line will be routed in and out of the new switching station. A 230 kV bus will be built from the Sand Hills Substation to the 230 kV switching station. The Interconnection Customer will connect their 230 kV transmission bus from the Wind Farm's Substation to SPS's Sand Hills Switching Station.

General Description of Modifications and New SPS² Facilities

1. **Construction of the New Switching Station:** See [Figure A-2](#) in [Appendix A](#) for one-line diagram and [Figure A-3](#) for a plan view of the station.
 - 1.1. **Location:** The new 230 kV switching station is located adjacent to K-18 on the south side and adjacent to the Customer's Sand Hills Substation. These facilities are located approximately 8.6 miles west of the Tolk Station in Block 205 in the Walker County School Land in the J.S. McMurtery Est. Ownership, Bailey County, Texas. See [Figure A-1](#) for a map of the local transmission system.
 - 1.2. **Bus Design:**
 - 1.2.1. The new 230 kV switching station will be built to accommodate the output from the wind energy facility. The new bus design will be a 3-breaker ring with 3 terminals expandable to a breaker and one half. The terminals will be: One for the tap to the wind farm connection from their substation; a second one for the 230 kV line from the Tolk Station; and a third one for the 230 kV line to Roosevelt Interchange. The new breaker design that is proposed is shown in [Figure A-2](#) in Appendix A.
 - 1.3. **Control House:** The control house will be utilized to house the new metering, protective relaying and control devices, terminal cabinets, and any fiber-optic cable terminations, etc. for the new 230 kV switching station.
 - 1.4. **Line Reactors:** None.
 - 1.5. **Security Fence:** The switching station will have a 7-foot chain-link fence with steel posts set in concrete, with 1-foot of barbed wire on the top in a "V" configuration.
 - 1.6. **Ground Grid:** A complete ground-grid will be installed per ANSI/IEEE STD 80-2000, with our standard 4/0 copper ground mesh on 40-foot centers with ground rods and 20-foot centers in the corners and the loop outside of the fence.
 - 1.7. **Site Grading:** Company contractor, per company specifications, will perform initial site grading and erosion control of the new switching station. Soil compaction shall be not less than 95% of laboratory density as determined by ASTM-D-698.

² All modifications to SPS facilities will be owned, maintained and operated by SPS.

- 1.8. **Station Power:** A 133 kV/120-240 volt transformer tapped off of the 230 kV bus will provide station power. A backup station power source will be taken from local distribution. Additionally, an automatic throw over switch to automatically transfer the station power will be installed.
- 1.9. **Relay and Protection Scheme:** The new switching station to the Tolk Station 230 kV line relaying will be directional comparison blocking (DCB) over power line carrier with a Pulsar TC10B. A SEL 321-1 (DCB) and a SEL 311-C (step distance) will be used. A SEL 279H-2 relay will be used for reclosing and a SEL 501-0 will be used for breaker failure.

The new switching station to Roosevelt Interchange 230 kV line relaying will utilize the same type of equipment as that of the Tolk Station 230 kV line.

The new switching station to the Interconnection Customer's owned line relaying will be step distance. A SEL 321-1 and a SEL 311-C will be used. A SEL 279H-2 relay will be installed; however, there will not be any automatic reclosing. The SEL 279H-2 will be used for line/bus conditions and sync check along with supervisory closing of the breaker. A SEL 501-0 will be used for breaker failure.

Two sets of 230 kV PTs will be installed on the north and south buses with disconnect switches. There will be a provision made for an automatic throw-over of the PTs. A manual transfer switch will be available for maintenance purposes.

On both the Tolk Station and Roosevelt Interchange lines, there will be CCVT's for line conditions. Line tuning units and wave traps will also be installed for the power line carrier communications.

Line arresters will be installed at each line termination on the dead-end towers.

- 1.10. **Revenue Metering:** On the 230 kV line to the Interconnection Customer's substation, a billing meter will be installed along with an ION 8400 meter unit, ANSI C12.1 accuracy class 0.2 (3 PTs IEEE C57.13 accuracy class 0.3 and 3 CTs IEEE C57.13 accuracy class 0.15) for full 3 phase 4-wire metering. The metering unit will have 1000/600:1 PTs and 200/400:5 CTs. There will be two meters; one will be primary and the other will be back up, and each will have full 4 quadrant metering. Pulses out of the primary billing meter will be sent via SCADA to the Amarillo Control Center. Metering at this new switching station will be installed to comply with present SPP market protocols.
- 1.11. **Disturbance Monitoring Device:** Disturbance-monitoring equipment, capable of recording faults, swings, and long term trending, will be installed to monitor and record conditions in the substation and on the transmission lines. This equipment will have communication capability with a dedicated communication circuit. The disturbance equipment will have its own dedicated dial-up communications telephone circuit. The disturbance equipment shall also be equipped with a GPS time synching clock.
- 1.12. **Remote Terminal Unit (RTU):** A new RTU will be utilized with communications. An SEL 2020 will be installed for relay communication and other functions as required.

- 1.13. **Communications:** Communications from the new switching station to the Amarillo Control Center will consist of a 4-wire telephone and data circuit. **It is the Requester’s responsibility to make arrangements with the local phone company to provide both the four-wire data circuit and both telephone circuits to the new switching station. Prior to any construction, the Requester is required to contact the Xcel Energy substation-engineering department for all details.**

A schematic outlining the proposed communications is provided below:

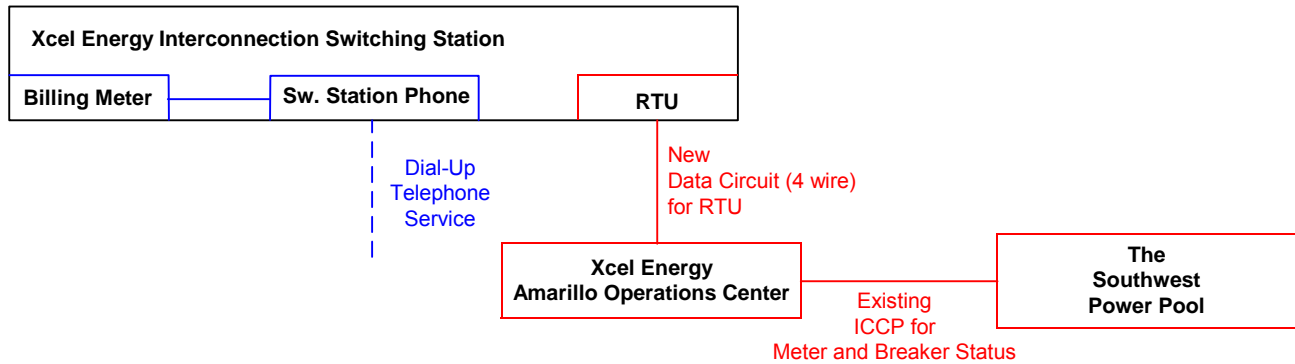

2. Transmission Line:

The Interconnection Customer will construct, own, operate, and maintain the new customer owned 230 kV transmission line/bus from the Interconnection Customer’s 230/34.5 kV substation to the new SPS switching station. [Figure A-4](#) shows the Point of Connection and Change of Ownership. **The Xcel Energy transmission design group will require an engineering review of the Interconnection Customer’s transmission line design prior to any construction by the Interconnection Customer or its contractor on the customer owned 230 kV transmission line or doing work in close proximity to any SPS transmission line, will require an engineering review in a timely manner before construction of the 230 kV transmission line begins. If the review has not been made or the design at any of the aforementioned locations is deemed inadequate, the crossing(s) and or termination into the new switching station will be delayed until the matters are resolved. Xcel Energy will not be held responsible for these delays.**

2.1. **230 kV Termination Structure:** The existing Xcel Energy overhead 230 kV transmission line (K-18) will be terminated in and out of the new switching station. The transmission termination structures will be constructed on the north side of the switching station. The existing 230 kV line between the Tolk Station and the Roosevelt Interchange will be re-terminated such that power flows in and out of the proposed switching station. The location of the switching station will be in Block 205 in the Walker County School Land in the J.S. McMurtery Est. Ownership, Bailey County, Texas.

2.2. The third 230 kV transmission terminations will be on the south side of the switching station for the Sand Hills Wind Farm. All circuits will be dead-ending on 230 kV terminals within the new switching station. See [Figure A-2](#).

3. Right-Of-Way:

- 3.1. **New 230 kV Transmission Line Taps:** See [Figure A-3](#) for location of the line taps relative to the switching station site.
 - 3.2. **Permitting:** Permitting for the construction of the new switching station is not required from the Public Utility Commission in the State of Texas.
 - 3.3. **Switching Station Location:** The new switching station will be constructed adjacent to the existing 230 kV transmission circuit K-18. SPS will provide the Interconnection Customer with easement detailing the metes and bounds description for the required real estate. The Interconnection Customer will obtain all necessary signatures from landowner(s) for the easement needed on the land where the new SPS switching station will be built.
4. **Construction Power and Distribution Service:** Both Construction and Station power, in addition to any distribution service required for the Interconnection Customer's wind-generated energy facility, are the sole responsibility of the Interconnection Customer. **Xcel Energy, Inc. cannot provide station power (retail distribution service) for the Interconnection Customer's substation if the location of the Interconnection Customer's substation lies outside of the Xcel Energy service area.**
5. **Project and Operating Concerns:** Close work between the Transmission group, the Interconnection Customer's Personnel, and local operating groups will be imperative to have this project in service on the scheduled date.

6. Short Circuit Study Results:

The Short Circuit Analysis was performed internally by Xcel Energy Services to determine the available fault current at the 230 kV bus of the new switching station. These values may be used as a starting point for the determination of the available fault currents and interrupting capability of their facilities. The results are shown in [Table 1](#), and the impedances are in per-unit at the specified voltage.

| Fault Location | Fault Current (A) | | Impedance (p.u Ω) ³ | |
|-----------------------------------|-------------------|---------|--|------------------|
| | Line-to-Ground | 3-Phase | Z ⁺ | Z ⁰ |
| New Switching Facility 230 kV Bus | 9,450 | 11,275 | 0.0016 + j0.0221 | 0.0076 + j0.0345 |

Estimated Construction Costs:

The projects required for the interconnection of the 160 MW wind energy generating facility consist of the projects summarized in [Table 2](#) shown below:

| Project | Description | Estimated Cost |
|---|---|---------------------|
| Stand-alone Network Upgrade | | |
| 1 | 230 kV 3-breakers ring configuration | \$ 2,266,682 |
| 2 | Right-of-Way Cost (station land, surveying, etc.) | \$ 5,000 |
| | Subtotal: | \$ 2,271,682 |
| Network Upgrade | | |
| 3 | Relay Modifications at Tolk and Roosevelt Interchange | \$ 177,763 |
| 4 | 230 kV Transmission Line Work | \$ 247,050 |
| | Subtotal: | \$ 424,813 |
| Interconnection Facilities (at the Interconnection Customer's Expense) | | |
| 5 | Communications ⁴ | \$ See footnote |
| 6 | Remote Terminal Unit (RTU) | \$ 54,120 |
| 7 | Revenue metering | \$ 95,084 |
| 8 | 230 kV Arresters | \$ 89,000 |
| | Subtotal: | \$ 238,204 |
| Total Cost: | | \$ 2,934,699 |

These costs were estimated using 2006 costs (2006 dollars) with no AFUDC⁵ added with an estimated accuracy is $\pm 20\%$.

Capital budget approval has not been sought for this project as of the date of this report. The required approval process may impact the projected in-service date requested by the Interconnection Customer.

³ Z⁺ – Positive Sequence Impedance in p.u on a 100 MVA base

Z⁰ – Zero Sequence Impedance in p.u on a 100 MVA base

⁴ It is the Requester's responsibility to provide both the data Circuit and both dial-up telephone circuits, see Section 1.13.

⁵ AFUDC - Allowance for Funds Used During Construction.

7. Engineering and Construction Schedule:

It is anticipated that the switching station and all associated components will be constructed and ready to receive power from the Interconnection Customer's wind farm approximately 15 months from the day an interconnection agreement is signed and after all internal approvals, unless prior arrangements have been made. This is the earliest Xcel Energy can complete the project as a result of other scheduling considerations. A construction schedule is shown below.

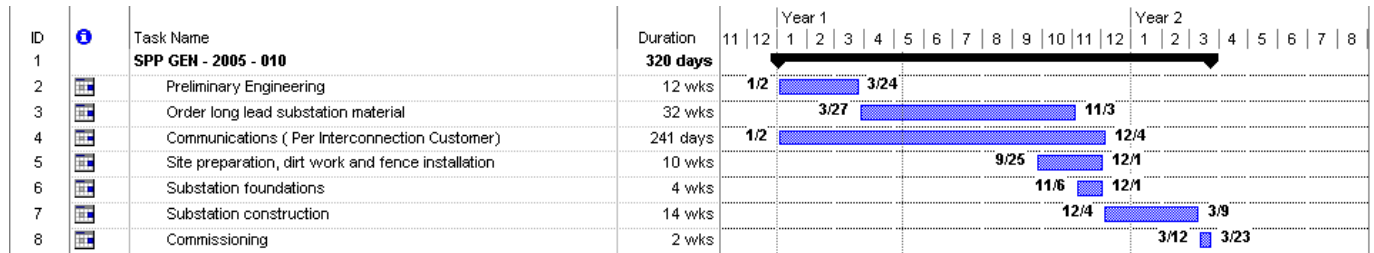

Appendix A

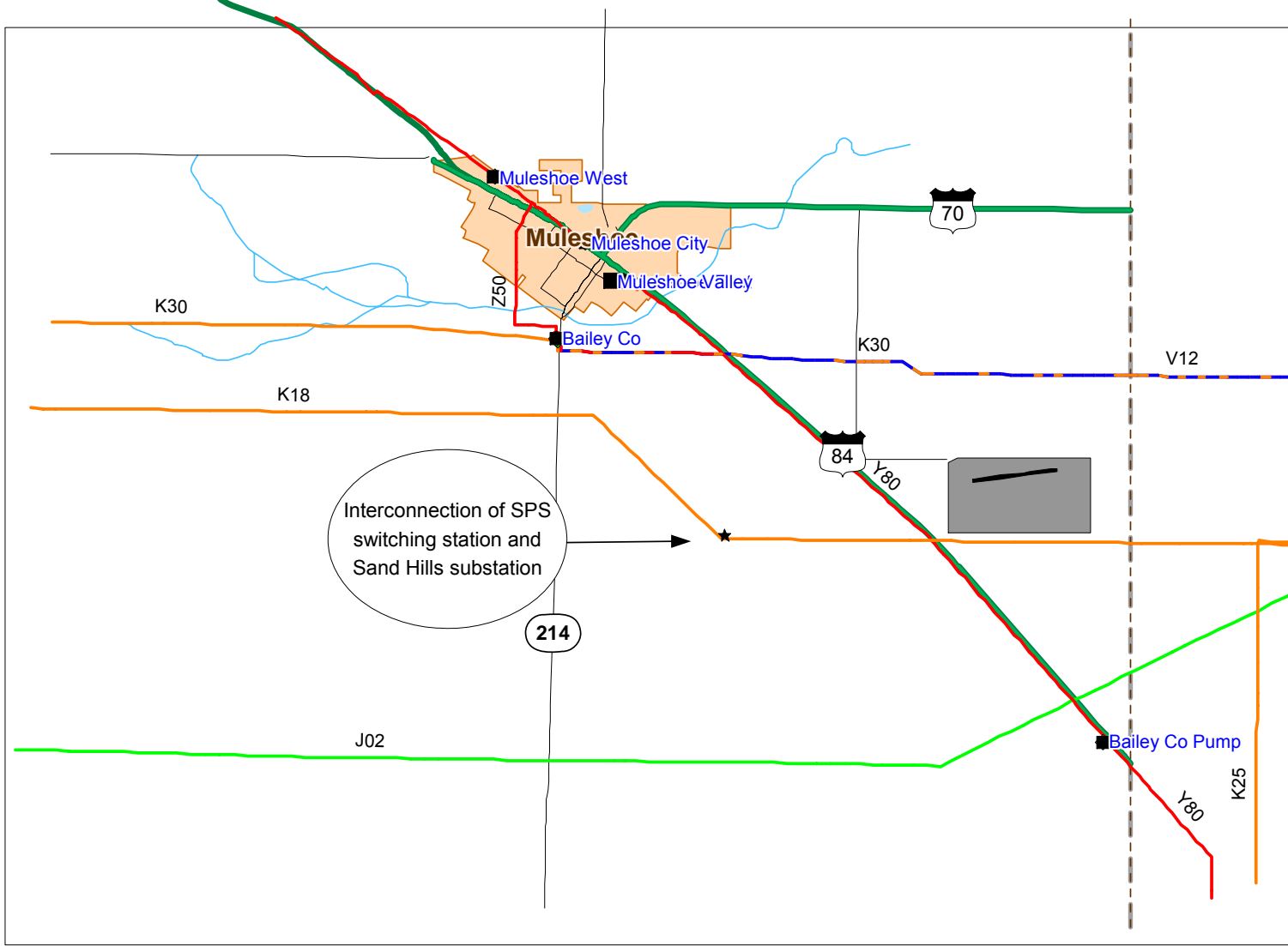

Figure A-1. Proposed Interception Point to the Xcel Energy 230 kV Circuit K-18.

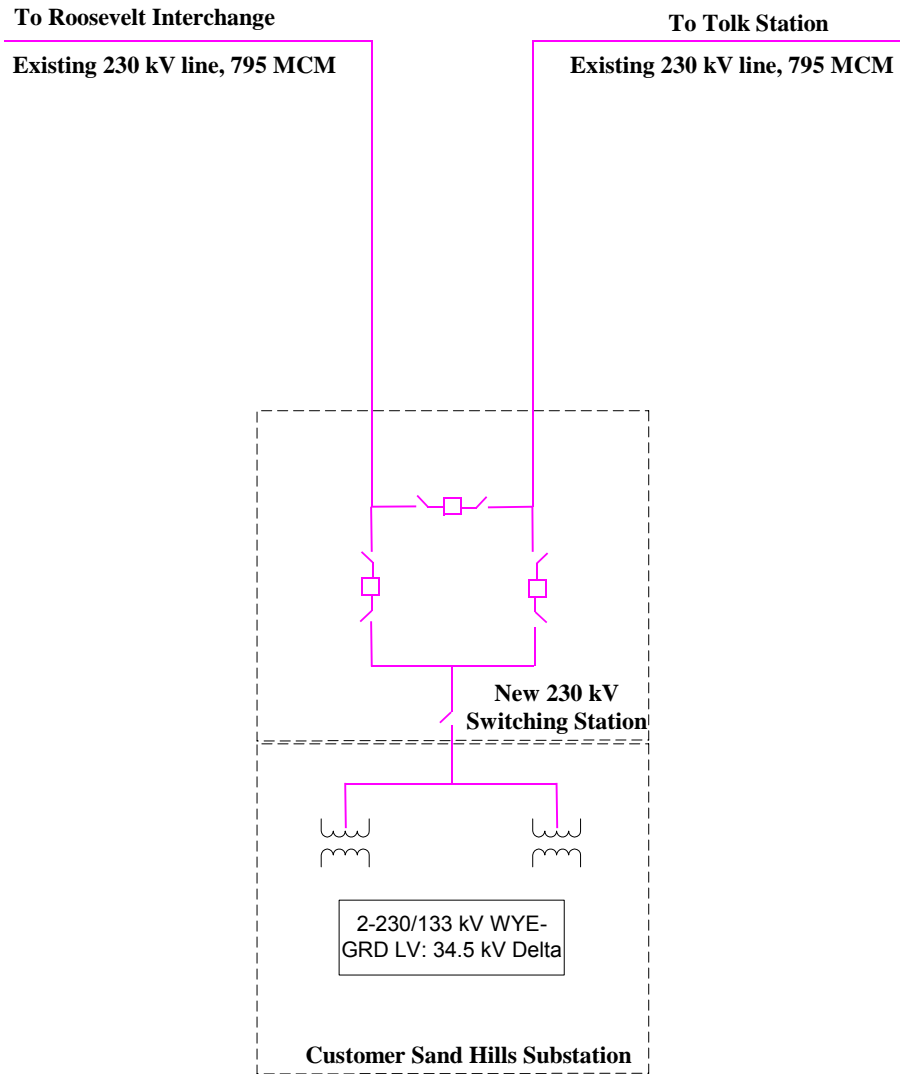

Figure A - 2. One-line diagram for Sand Hills Wind and a new 230 kV Switching Station in Bailey County.

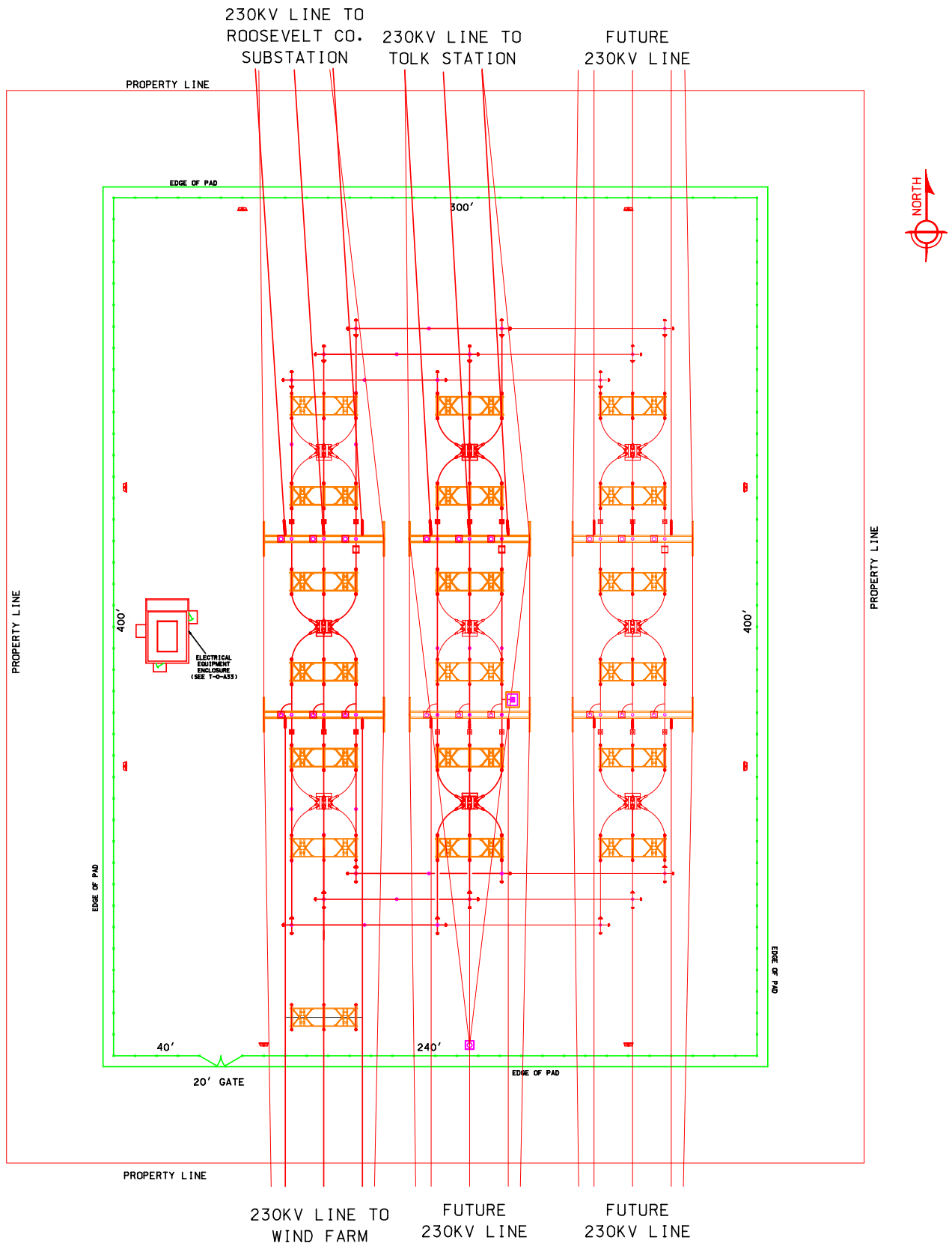

Figure A-3. Site Layout 230 kV Sand Hills Switching Station.

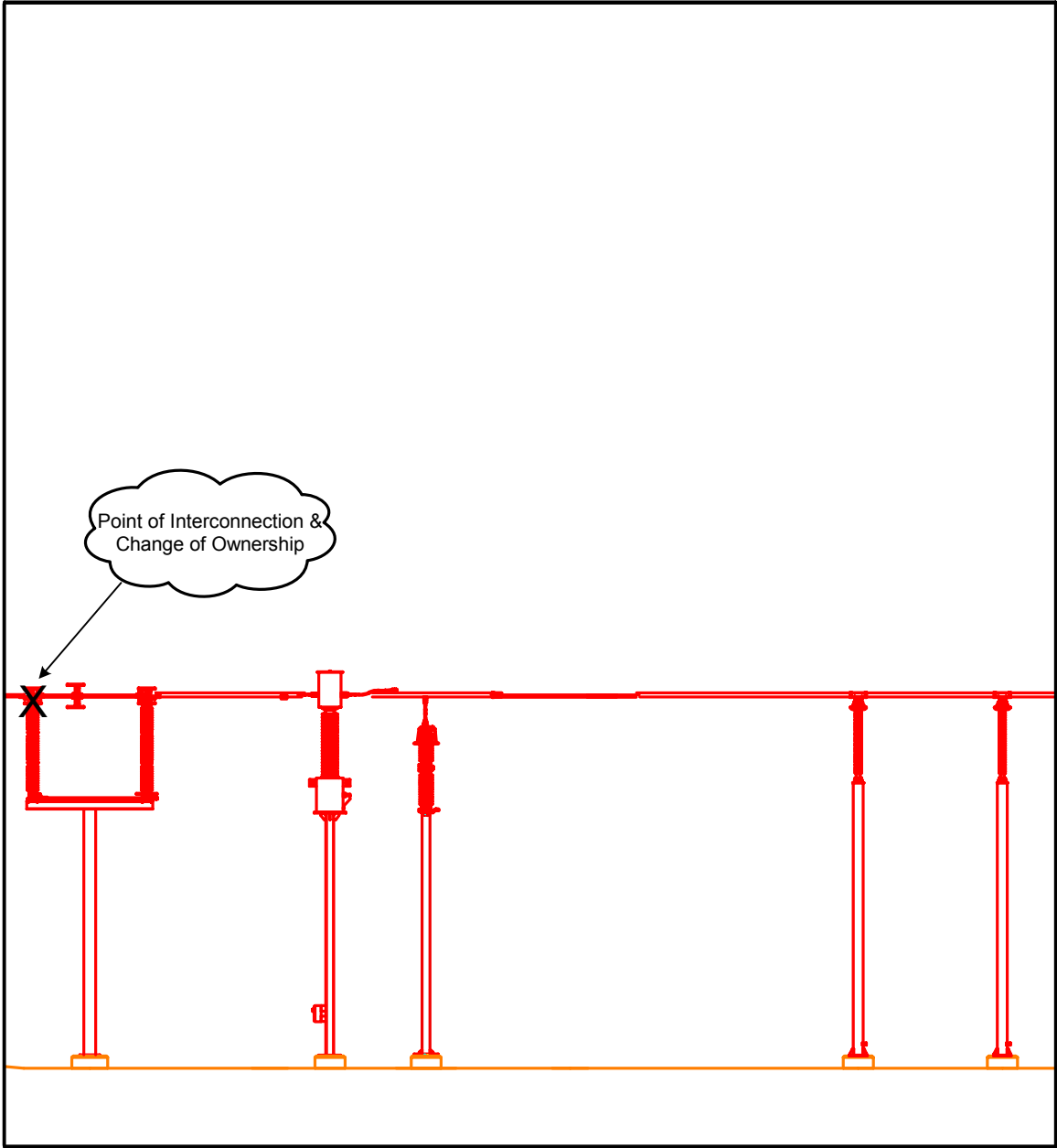

Figure A-4. Point of Interconnection & Change of Ownership.