



***Facility Study for Generation  
Interconnection Request  
GEN – 2005 – 007***

***SPP Tariff Studies  
(#GEN-2005-007)***

**July, 2006**

## **Summary**

Pursuant to the tariff and at the request of the Southwest Power Pool (SPP), Xcel Energy (Xcel) performed the following Facility Study to satisfy the Facility Study Agreement executed by the requesting customer and SPP for SPP Generation Interconnection request Gen-2005-007. The request for interconnection was placed with SPP in accordance SPP's Open Access Transmission Tariff, which covers new generation interconnections on SPP's transmission system.

In addition to costs detailed in this Facility Study, the Customer is also responsible for purchasing the generator with a power system stabilizer (PSS) as detailed in the impact study.



**Facilities Study For  
GEN-2005-007**

260 MW Generator Facilities  
Hutchinson County, Texas  
SPP #GEN-2005-007

June 25, 2006

Xcel Energy Services, Inc.  
Transmission Planning

## Executive Summary

[Omitted Text] (Interconnection Customer) has requested the connection of a 260 MW generator to the Southwestern Public Service Company (SPS) (d/b/a Xcel Energy, Inc) 230 kV bus at Hutchinson Interchange, located approximately 2 miles southwest of Borger, TX. The Southwest Power Pool (SPP) evaluated the request to connect this generator facility to the SPS system in the System Impact Study completed in January 2006.

The proposed generator facility will have a rated output of 260 MW with an in service date of June 1, 2009, with a back feed to generation date of September 2007.

Xcel Energy will require the Interconnection Customer to construct the Interconnection Facilities in compliance with the latest revision of the Xcel Energy Interconnection Guidelines for Transmission Interconnection Producer-Owned Generation Greater than 20 MW, Version 2.0 dated January 20, 2004. This document describes the requirements for connecting new generation to the Xcel Energy operating company transmission systems including technical, protection, commissioning, operation and maintenance. Xcel Energy will also require that the Interconnection Customer be in compliance with all applicable criteria, guidelines, standards, requirements, regulations and procedures issued by the North American Electric Reliability Council, (NERC), Southwest Power Pool, and Federal Energy Regulatory Commission or their successor organizations.

The Interconnection Customer is responsible for the cost of the Interconnection Customer Facilities and any Direct Assigned Facilities; inclusive of all construction required for the 230 kV transmission line from the Interconnection Customer's substation to Hutchinson Interchange. The cost of the upgrades is shown below, with the detailed description of the cost shown in Table 3.

Network Upgrade:	\$ 135,193
Direct Assigned Facilities <sup>1</sup> :	\$ 312,630
Interconnection Facilities <sup>1</sup> :	\$ 417,222
<u>Total:</u>	<u>\$ 865,045</u>

---

<sup>1</sup> This is a direct assigned cost to the Interconnection Customer.

## Discussion

### General Description of Existing SPS Facilities

The existing Hutchinson Interchange is made up of a straight bus design with two 230 kV breaker terminals; one from Nichols Station and one spare that was from Harrington. There are approximately twenty 230 kV structures from Hutchinson Interchange towards the Harrington to Pringle 230 kV transmission line, which were not removed when the Harrington 230 kV transmission line was re-routed from Hutchinson Interchange to Pringle Interchange. Hutchinson Interchange has two 150 MVA, 230/115 kV autotransformers, six 115 kV breaker terminals, one 84 MVA, a 115/69 kV autotransformer with three 69 kV terminals. This station is located southwest of Borger, Texas.

### General Description of Modifications to Existing SPS<sup>2</sup> Facilities

#### 1. Hutchinson Interchange Modifications.

- 1.1. **Location:** Hutchinson Interchange is located approximately 2 miles southwest of Borger, TX. See Figure A - 2 for a map of the area.
- 1.2. **Bus Design:** The existing bus design at Hutchinson Interchange is a straight bus design with no transfer bus and has one 230 kV breaker in service, one 230 kV breaker out of service, six 115 kV breakers and three 69 kV breakers. There are two 150 MVA, 230/115 kV autotransformers and one 84 MVA, 115/69 kV autotransformer.
- 1.3. **Additions/Modifications:** The existing bus design at Hutchinson Interchange will not need to be modified. The existing spare 230 kV breaker can accommodate the output from the generator facility at Blackhawk II. The existing 230 kV breaker terminal that will be used is shown on the one-line diagram in
- 1.4.
- 1.5. Figure A - 1.
- 1.6. **Control House:** The existing control house will be utilized to house the new revenue metering, protective relaying and control devices, terminal cabinets, and any fiber-optic cable terminations, etc. for the new connection from the generator at Blackhawk.
- 1.7. **Security Fence:** The existing fence at Hutchinson Interchange is made of a 7-foot chain-link fence with steel posts set in concrete, with 1-foot of barbed wire on the top in a "V" configuration. The enclosed area is approximately 420' x 390', with a rock yard surface.
- 1.8. **Ground Grid:** The interchange has an existing ground grid installed per previous versions of ANSI/IEEE STD 80.
- 1.9. **Site Grading:** Additional work is not required.

---

<sup>2</sup> All modifications to SPS facilities will be owned, maintained and operated by SPS.

- 1.10. **Station Power:** Station power is provided from the local distribution system, with backup power off the tertiary of the 230/115 kV autotransformer.
- 1.11. **Relay and Protection Scheme:** The Hutchinson Interchange to the customer owned line relaying will be step distance. An SEL 321-1 and an SEL 311-C will be used. An SEL 292H-2 will be installed; however no automatic re-closing will be installed. The SEL 292H-2 will be used for line/bus conditions and sync check with supervisory closing of the 230 kV breaker. Finally, an SEL-501-0 will also be installed for breaker failure. The proposed 230 kV breaker terminal at Hutchinson Interchange has been tested and is ready for service.
- 1.12. **Revenue Metering:** On the 230 kV line from Blackhawk II Generator to Hutchinson Interchange, a billing meter will be installed along with an ION 8400 meter unit, ANSI C12.1 accuracy class 0.2 (3 PTs IEEE C57.13 accuracy class 0.3 and 3 C.T.'s IEEE C57.13 accuracy class 0.15) for full 3 phase 4-wire metering. The metering will utilize existing station PT's and new 230 kV self-contained C.T.'s will be installed. There will be two meters: one will be primary and the other will be back-up. Each will have full 4 quadrant metering. Pulses out of the primary billing meter will be sent via SCADA to the Amarillo Control Center.
- 1.13. **Disturbance Monitoring Device:** Disturbance-monitoring equipment, capable of recoding faults, swings, and long term trending, will be installed to monitor and record conditions in the Hutchinson Interchange and on the transmission lines. This equipment will have communication capability with a dedicated communication circuit. The Disturbance equipment shall also be equipped with a GPS time synchronizing clock. The Disturbance equipment will have its own dedicated dial-up communications circuit.
- 1.14. **Communications:** The existing RTU at Hutchinson Interchange will need to be upgraded. An SEL 2020 will be installed for relay communications and other functions as required. The existing RTU at Blackhawk may need to be upgraded by the Interconnection Customer.

Communications from Hutchinson Interchange to the Amarillo Control Center will consist of existing microwave telephone and data circuit.

A schematic outlining the proposed communications is provided below:

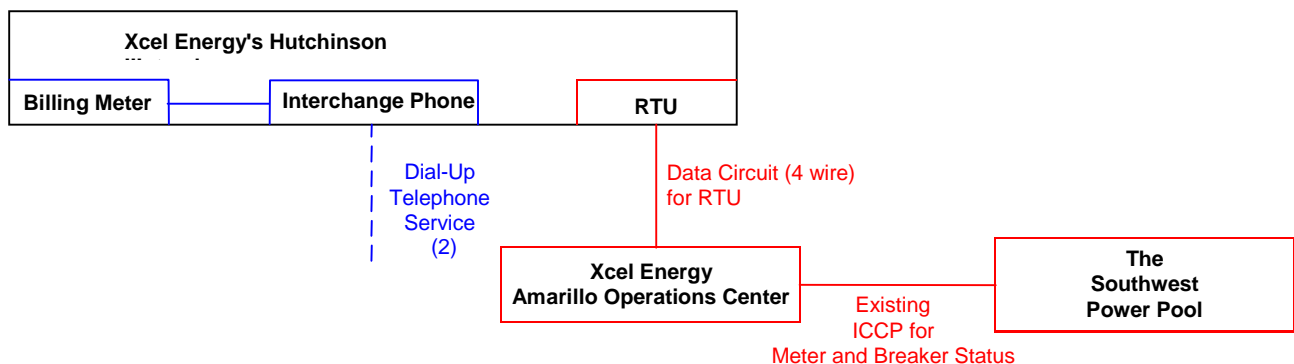

## 2. Transmission Work:

The Interconnection Customer will construct, own, operate, and maintain the new 230 kV transmission line from the Interconnection Customer's substation to Hutchinson Interchange.

***The Xcel Energy transmission design group prior to any construction by the Interconnection Customer or its contractor on the customer owned 230 kV transmission line, or doing work in close proximity to any SPS transmission line, will require an engineering review of the customer's design. It is the Interconnection Customer's responsibility to initiate the design review in a timely manner before construction of the 230 kV transmission line begins. If the review has not been made or the design at any of the aforementioned locations is deemed inadequate, the crossing(s) and/or termination into Hutchinson Interchange will be delayed until the matters are resolved. Xcel Energy will not be held responsible for these delays.***

- 2.1. **Termination Structure:** The Interconnection Customer's 230 kV line termination structure located outside the Hutchinson Interchange will need to be replaced by SPS with a new dead-end structure. This is to assure that proper clearance is maintained on the joint dead-end structure and the slack span to the termination structure into Hutchinson Interchange. The Interconnection Customer will need to terminate their 230 kV transmission line on the new joint dead-end structure at Hutchinson Interchange, which is one span west of Hutchinson Interchange. See Figure A - 4, which shows the Point of Interconnection and Change of Ownership.
- 2.2. **Joint Structure:** A joint 230 kV dead-end structure will be built by SPS at the location where the customer's owned 230 kV transmission line and Xcel Energy's 230 kV transmission circuit intersect, which is located one span west of Hutchinson Interchange. SPS will provide the necessary material for the SPS portion of the dead-end structure (see Figure A - 3). An Xcel Energy inspector will be the final authority on the installation of this structure. The joint structure is required to provide proper clearance between an de-energized circuit and the customer owned 230 kV transmission circuit.
- 2.3. **69 kV and 115 kV Transmission Line Crossings:** SPS will install joint structures for the crossings of the double 115/69 kV circuit, a single 69 kV circuit and the two 115 kV circuits on the west side of Hutchinson Interchange. In the event any other SPS transmission lines are crossed, proper clearances above these transmission lines shall be maintained. An Xcel Energy inspector will have final authority on whether proper clearance above these circuits and other circuits are maintained. If clearance cannot be maintained, a joint crossing structure will be required. If any additional crossing structures are required, the costs will be the responsibility of the Interconnection Customer.
- 2.4. **Transmission Line Ground Clearance:** It is required that the Interconnection Customer's 230 kV transmission circuit maintain a minimum ground clearance of 39 feet at worst case sag (as per NESC<sup>3</sup> rules) for the entire route, which shows to be parallel to SPS's 115 kV transmission line circuit T-48 from Hutchinson Interchange to

---

<sup>3</sup> National Electric Safety Code

Blackhawk. An Xcel Energy inspector will have final authority on whether proper clearance has been maintained.

3. **Right-Of-Way:**

3.1. **Additional Real Estate:** It is not required to purchase additional land for the work that will be performed at Hutchinson Interchange.

3.2. **Permitting:** It is not required to obtain a permit from the Public Utility Commission of Texas for the addition of the breaker terminal.

4. **Construction Power and Distribution Service:** It is the sole responsibility of the Interconnection Customer to make arrangements for both construction and station power, which may be required for the Interconnection Customer’s generator facility. **Additionally, if the Interconnection Customer’s substation(s) and/or construction site(s) lie outside of the Xcel Energy service area, Xcel Energy cannot provide station power (retail distribution service) and the Interconnection Customer needs to make arrangements for distribution service from the local retail provider.**

5. **Project and Operating Concerns:** Close work between the Transmission group, the Interconnection Customer’s personnel, and local operating groups will be imperative in order to meet any in-service date that has been established.

6. **Fault Current:** The available fault current on the 230 kV bus at Hutchinson Interchange, with and without any contribution from the generator, is shown in Table 1 and Table 2.

**Table 1, Available Fault Current at 230 kV Hutchinson Bus**

<b>With Generator</b>		
<b>Fault Type</b>	<b>Amps</b>	<b>MVA</b>
Three Phase	8725	3475
Single-Line-To-Ground	8025	3200

<b>Without Generator</b>		
<b>Fault Type</b>	<b>Amps</b>	<b>MVA</b>
Three Phase	6875	2750
Single-Line-To-Ground	6100	2425

**Table 2, Source Impedance<sup>4</sup> Data at 230 kV Hutchinson Bus**

<b>With Generator</b>	
<b>Positive (Z<sup>+</sup>)</b>	<b>Zero (Z<sup>0</sup>)</b>
0.00144 + j0.02856	0.0002 + j0.03582

<b>Without Generator</b>	
<b>Positive (Z<sup>+</sup>)</b>	<b>Zero (Z<sup>0</sup>)</b>
0.00244 + j0.03620	0.0002 + j0.04925

<sup>4</sup> Values are in per-unit on a 100 MVA base.



**Estimated Construction Costs:**

The projects required for the interconnection of this 260 MW generation facility from Blackhawk II are summarized in the table below: (The estimated costs are for 2006 dollars. This is an appropriation estimate, which requires completion within 90 days with at least ±20% accuracy in cost estimation.)

**Table 3, Required Interconnection Projects**

<b>Project</b>	<b>Description</b>	<b>Estimated Cost</b>
1	<b>Network Upgrade</b>	
	Relay Upgrades	\$ 135,193
	<b>Subtotal:</b>	<b>\$ 135,193</b>
2	<b>Direct Assigned Facilities</b> <sup>6</sup>	
	Transmission 230 kV Joint Structures installed by SPS (5)	\$ 312,630
	<b>Subtotal:</b>	<b>\$ 312,630</b>
	<b>Interconnection Facilities</b> <sup>5</sup> (at the Interconnection Customer's Expense)	
3	Communications <sup>6</sup>	\$ See footnote
4	Remote Terminal Unit (RTU)	\$ 54,120
5	230 kV Revenue Metering	\$ 95,084
6	230 kV Breaker	\$ 268,018
	<b>Subtotal:</b>	<b>\$ 417,222</b>
	<b>Total Cost:</b>	<b>\$ 865,045</b>

<sup>5</sup> At the present time, it is not anticipated that distribution relocation will be required; if needed, a customer cost will be incurred.

<sup>6</sup> It is the Interconnection Customer's responsibility to provide both the data circuit and both dial-up telephone circuits. See Section 1.13.

## 7. Engineering and Construction:

The Interconnection Customer is building the 230 kV line from Blackhawk II to Hutchinson Interchange and there will be joint 230 kV dead-end with SPS one span to the west of Hutchinson Interchange. The SPS 230 kV transmission line is de-energized. The in service date is June 1, 2009, with a back feed date of September 2007. The new 230 kV line terminal relaying will be changed. A new RTU will be installed at Hutchinson Interchange. A new RTU at Blackhawk may be required. A construction schedule is shown below.

ID	Task Name	Year 1												Year 2									
		9	10	11	12	1	2	3	4	5	6	7	8	9	10	11	12	1	2	3	4	5	6
1	<b>SPP GEN-2005-007</b>																						
2	Preliminary Engineering				1/2																		
3	Order Transmission line material								2/27														
4	Install Transmission line structures																						
5	Order RTU and metering equipment																						
6	Install RTU & metering equipment																						
7	Commissioning																						

All additional cost for work not identified in this study is the sole responsibility of the Interconnection Customer unless other arrangements are made.

## 8. Requirements For Interconnection Customer:

***As such, Xcel Energy, prior to any construction of this generation facility, will require a review of the Interconnection Customer's final design. It is the Interconnection Customer's responsibility to initiate the design review in a timely manner; Xcel Energy will not be held responsible for any delays.*** The review is to assure that the design of the generator facility (substation locations, breaker arrangements, relaying, etc.) does not cause any future problems to the transmission system.

Per the System Impact Study, the Interconnection Customer will specify and purchase a power system stabilizer (PSS) for the generator.

# Appendix A

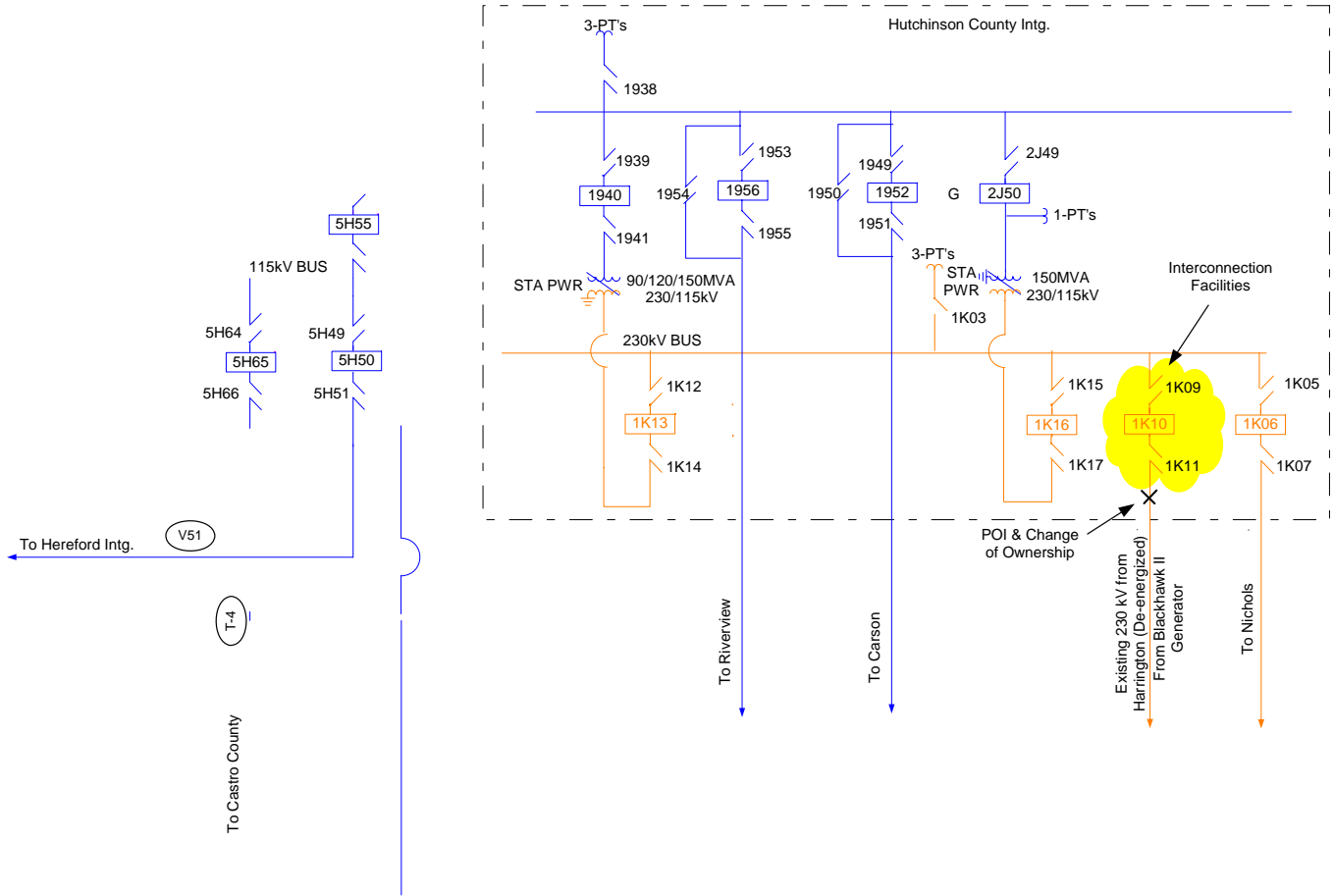

**Figure A - 1 Hutchinson Interchange One-line Diagram**

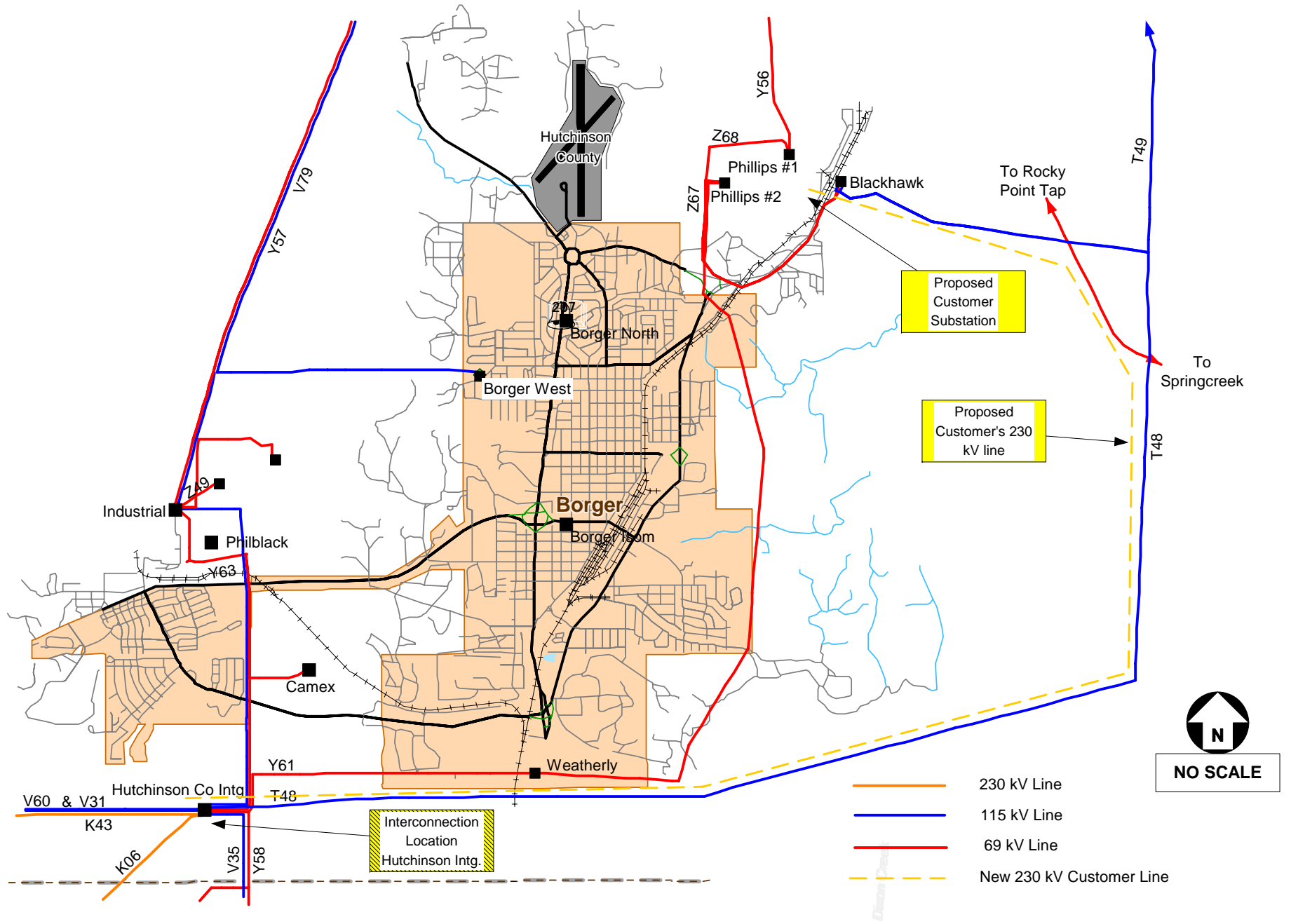

Figure A - 2 Location Map for Blackhawk to Hutchinson Interchange.

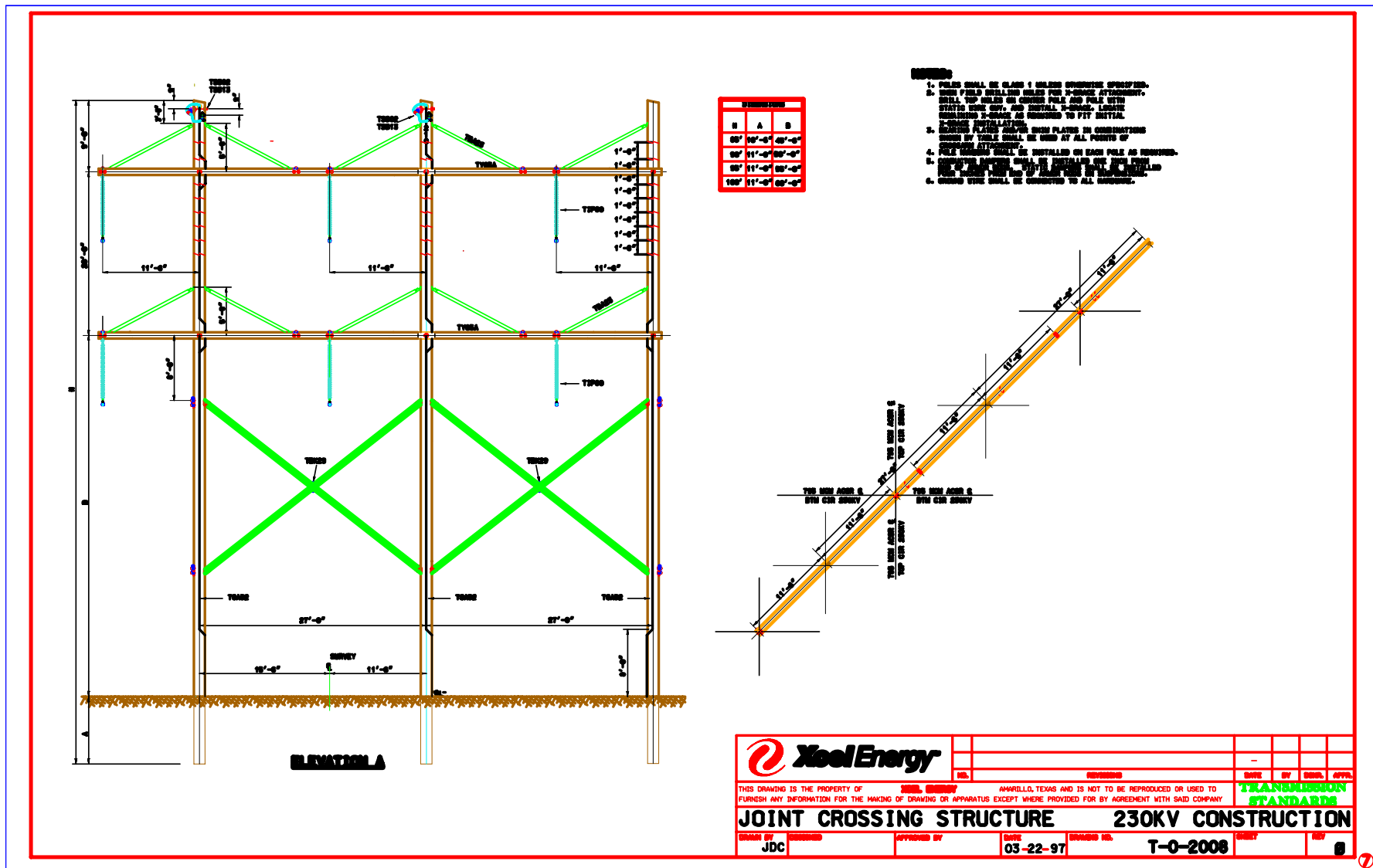

Figure A - 3 Joint 230 kV Crossing Structure

HUTCHINSON COUNTY INTERCHANGE

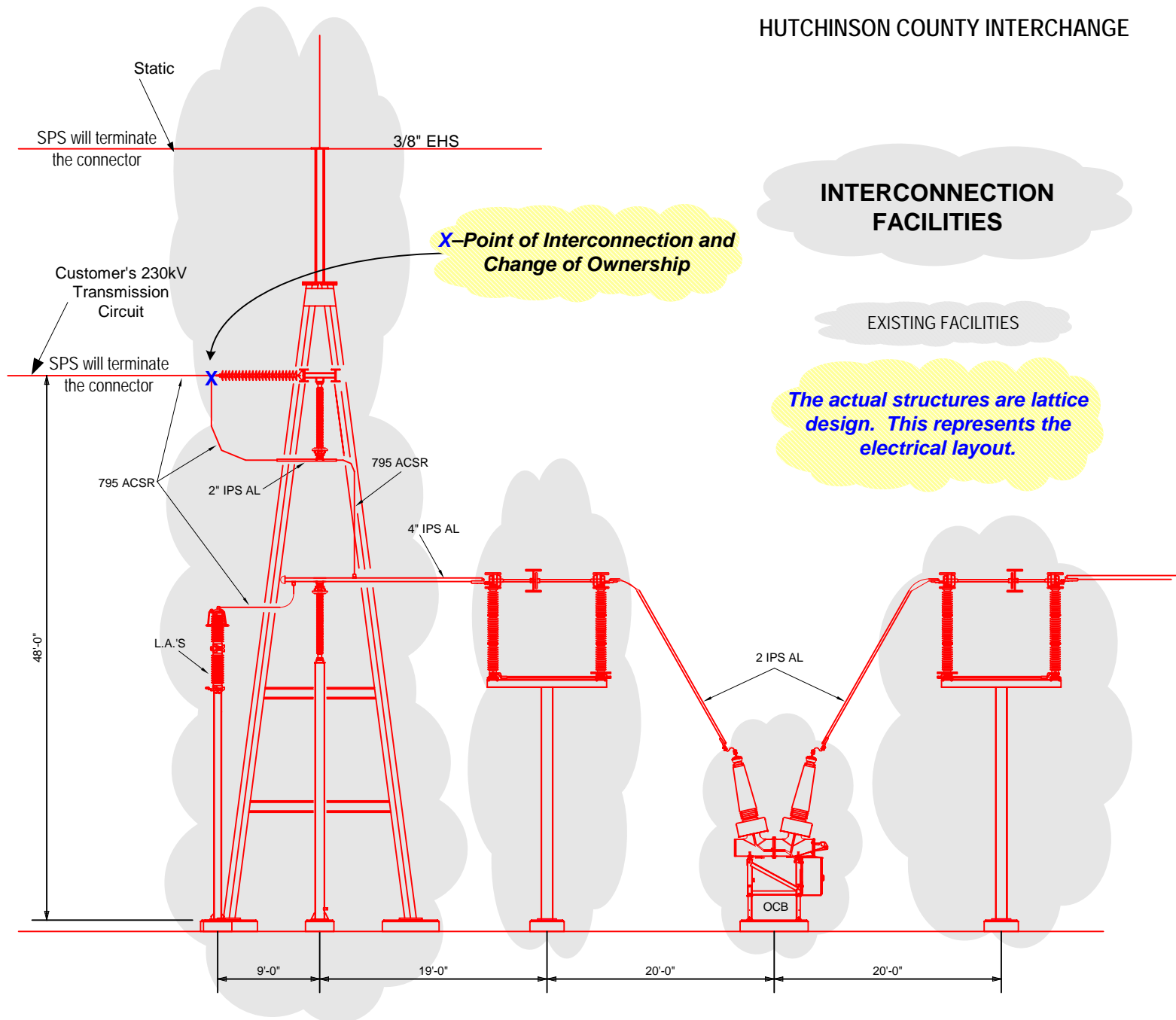

Figure A - 4 Point of Interconnection and Change of Ownership