



***Feasibility and Impact Study for
Generation Interconnection
Request
GEN – 2003 – 022***

***SPP Coordinated Planning
(#GEN-2003-022)***

June 2004

1 Summary

ABB performed the following study at the request of the Southwest Power Pool (SPP) for SPP Generation Interconnection request Gen-2003-022. The request for interconnection was placed with SPP in accordance SPP's Open Access Transmission Tariff Attachment V, which covers new generation interconnections on SPP's transmission system.

Pursuant to the tariff, ABB was asked to perform a detailed stability analysis of the generation interconnection requests to satisfy the System Impact Study Agreement executed by the requesting customer and SPP.



FEASIBILITY AND IMPACT STUDIES
FOR GENERATION
INTERCONNECTION REQUEST
GEN-2003-022

Prepared for: SOUTHWEST POWER POOL

Final Report

REPORT NO.: Consulting 2004-10887-V02
June 8, 2004

Submitted by:

**ABB Electric System Consulting
940 Main Campus Drive, Suite 300
Raleigh, NC 27606**

Southwest Power Pool	No. 2004-10887-V02		
Title: Feasibility and Impact Studies for Generation Interconnection Request (GEN-2003-022)	Dept. ESC	Date June 11, 2004	Pages 36

Authors: Lan Trinh, Ravi Varanasi

Reviewer: William Quaintance

Summary

Southwest Power Pool (SPP) has requested feasibility and impact studies on behalf of <Customer> for the purpose of interconnecting a 120MW wind farm (80 GE 1.5 MW wind turbine generators) in the Weatherford, Oklahoma vicinity, within the service territory of American Electric Power (AEPW). The proposed wind farm will be connected to a new switching station to be constructed on the Weatherford Southeast – Clinton Junction 138 kV line and located approximately 3 miles from Weatherford tap. The proposed in-service date is December 2004. The generation developer requested that the feasibility study also be conducted for an alternate interconnection point located approximately 4 miles to the east of the proposed interconnection point described previously.

Power flow analysis indicates that, for the conditions studied, it is possible to interconnect up to 130 MW to either of the proposed locations. There are no significant thermal violations due to the proposed plant, when considering branches with distribution factors above 3% and ignoring pre-existing overloads. Also, there are no new voltage violations caused by the proposed plant.

Based on the results of the feasibility study, the developer and SPP requested that ABB perform the impact study of the wind farm using the primary point of interconnection at a generation level of 120 MW.

Based on the results of the stability analysis, it is concluded that the wind farm at 120 MW does not adversely impact the stability of the SPP system.

The results of this analysis are based on available data and assumptions made at the time of conducting this study. If any of the data and/or assumptions made in developing the study model change, the results provided in this report may not apply.

Rev. #	Revision	Date	Author	Reviewed	Approved
DISTRIBUTION: John E. Mills, Southwest Power Pool					

LEGAL NOTICE

This document, prepared by ABB Inc., is an account of work sponsored by Southwest Power Pool. Neither Southwest Power Pool nor ABB Inc., nor any person or persons acting on behalf of either party: (i) makes any warranty or representation, expressed or implied, with respect to the use of any information contained in this report, or that the use of any information, apparatus, method, or process disclosed in this report may not infringe privately owned rights, or (ii) assumes any liabilities with respect to the use of or for damages resulting from the use of any information, apparatus, method, or process disclosed in this document.

Table of Contents

1	INTRODUCTION.....	1
2	POWER FLOW ANALYSIS.....	4
2.1	POWER FLOW ANALYSIS METHODOLOGY	4
2.2	POWER FLOW CASES.....	4
2.3	POWER FLOW ANALYSIS RESULTS	4
3	STABILITY ANALYSIS.....	7
3.1	STABILITY ANALYSIS METHODOLOGY	7
3.2	STUDY MODEL.....	8
3.3	STABILITY RESULTS.....	12
4	STUDY CONCLUSIONS	17
	APPENDIX A – POWER FLOW SIMULATION SETTINGS.....	18
	APPENDIX B – COLLECTOR SYSTEM.....	21
	APPENDIX C - STABILITY MODEL PARAMETERS FOR WIND FARM.....	23
	APPENDIX D – COMPLETE POWER FLOW RESULTS	28
	APPENDIX E – STABILITY PLOTS.....	30

2 INTRODUCTION

SPP has requested feasibility and impact studies for the purpose of interconnecting a 120MW wind farm (80 GE 1.5 MW wind turbine generators) in the Weatherford, Oklahoma vicinity, within the service territory of American Electric Power (AEPW). The proposed wind farm will be connected to a new switching station to be constructed on the Weatherford Southeast – Clinton Junction 138 kV line and located approximately 3 miles from Weatherford tap. The proposed in-service date is December 2004. The generation developer requested that the feasibility study also be conducted for an alternate interconnection point located approximately 4 miles to the east of the proposed interconnection point described previously. After the feasibility (power flow) study was complete and before the impact (stability) study was begun, the developer requested that the impact study be performed only for the primary interconnection point, and the wind farm capacity was changed from 130 MW to 120 MW.

The objective of the feasibility study is to determine whether there are any steady-state criteria violations associated with the interconnection of the proposed wind farm. The incremental impact of the proposed wind farm under system intact and contingency case conditions would be determined by comparing the transmission system power flows and bus voltages both with and without the proposed wind farm.

As mentioned previously, the feasibility study was performed for both the proposed and the alternate points of interconnection. Based on the results of the feasibility study, the generation developer chose the primary point of interconnection for the system impact study.

The objective of the impact study is to determine the impact on system stability of connecting the 120 MW wind farm to the single chosen interconnection point.

WINDFARM CONCEPTUAL ONE-LINE DIAGRAM

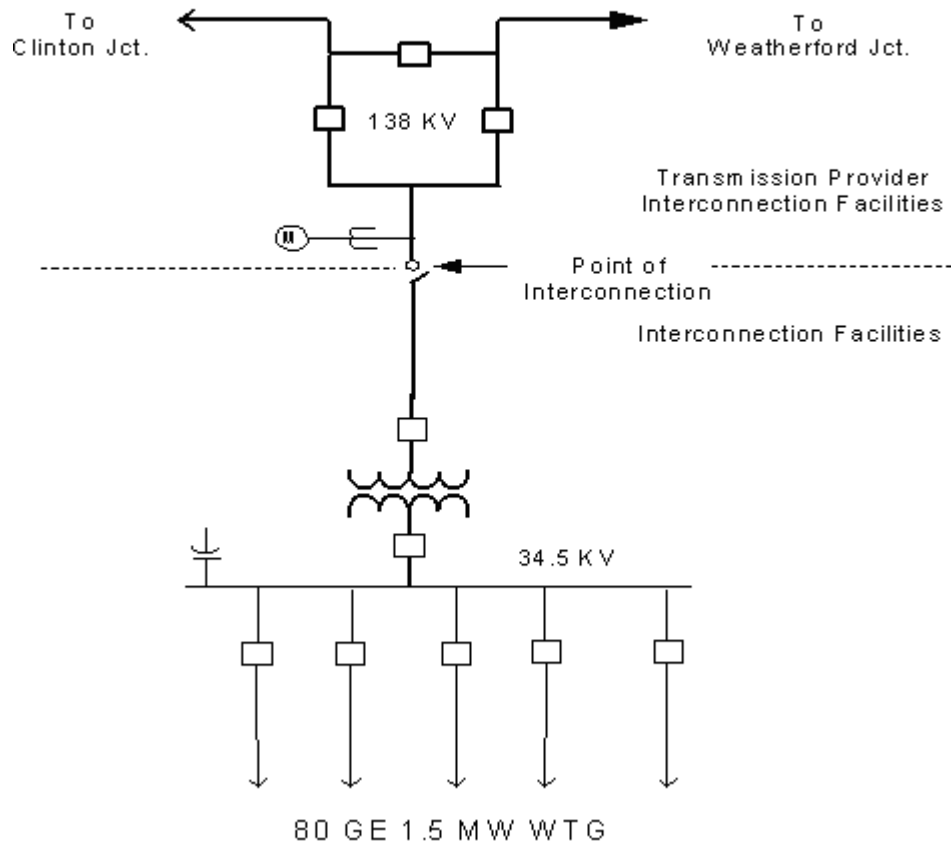

Figure 1. Proposed Interconnection of Wind Farm

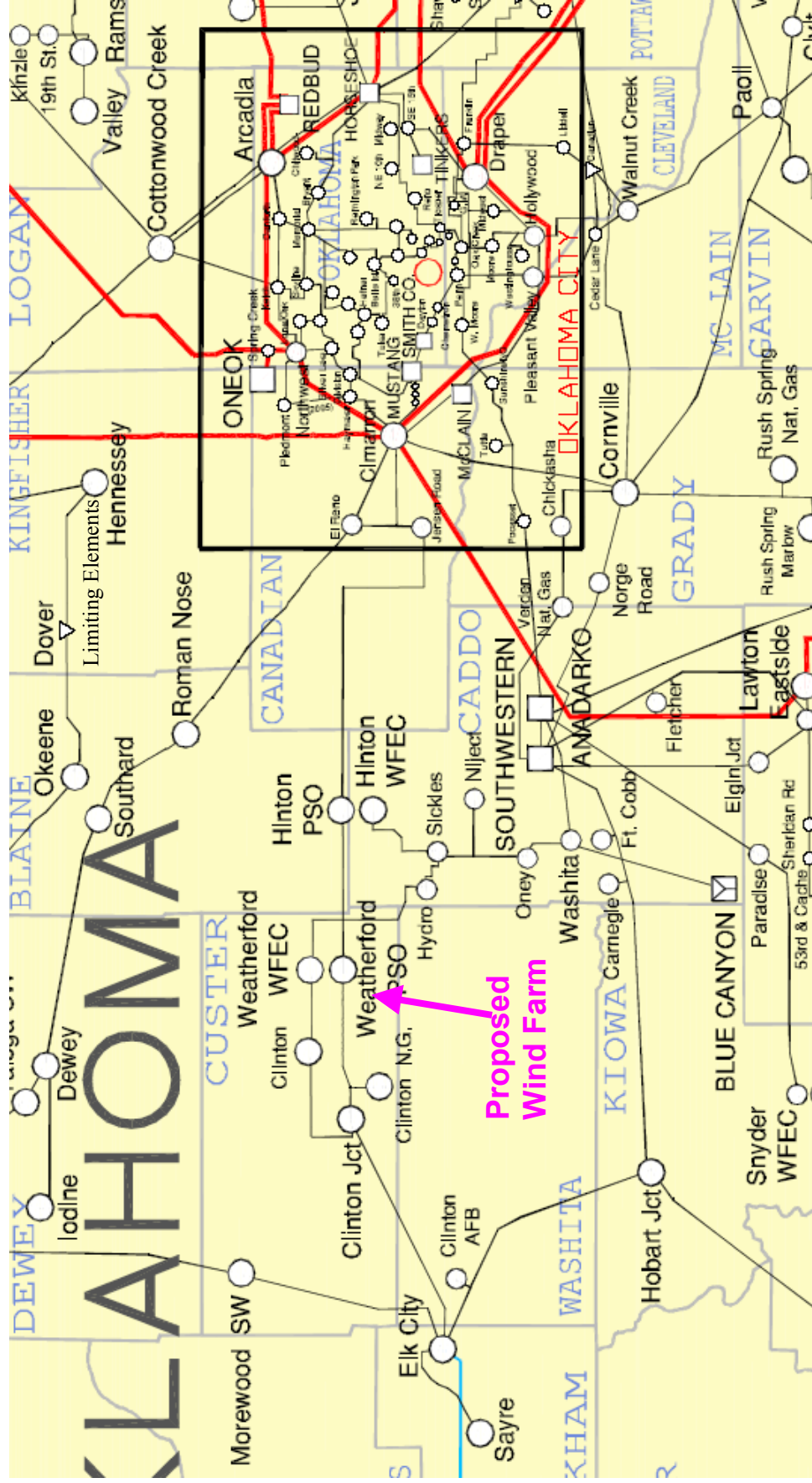

Figure 2: Map of the surrounding area

3 POWER FLOW ANALYSIS

3.1 Power flow Analysis Methodology

The Southwest Power Pool (SPP) criteria states that the transmission system of the SPP region shall be planned and constructed so that the contingencies as set forth in the criteria will meet the applicable NERC Planning Standards for System Adequacy and Security of Transmission Systems, Table 1 (hereafter referred to as NERC Table 1), and its applicable standards and measurements.

PTI's MUST First Contingency Incremental Transfer Capability (FCITC) DC analysis was used to study transmission system loadings under system intact and contingency conditions as power from the proposed wind farm is increased from 0 MW to its maximum capacity. The MUST options chosen to conduct the study can be found in Appendix A.2.

PTI's PSSE ACCC analysis was used to study bus voltages under system intact and contingency conditions both with and without the proposed wind farm. The ACCC options chosen to conduct study can be found in Appendix A.1.

There are several other proposed wind generation additions in the general area of the proposed facility. It was assumed in the analysis that not all of these other projects were in service. Those previously queued projects that have advanced to nearly complete phases were included in this feasibility study (included were Gen-2003-004, Gen-2003-005, and Gen-2002-005). Significant differences in the assumptions used in this feasibility study may require that this study be revisited to determine this facility's impacts on the SPP transmission system.

3.2 Power flow Cases

A power flow analysis was conducted for the facility using modified versions of the 2004 series SPP Planning models. The in-service date of the facility is proposed to be December 2004. The models used in this study were: 2005 Fall Peak, 2005 Summer Peak, 2005 Winter Peak, 2007 Summer Peak, 2007 Winter Peak, 2010 Summer Peak, and a 2010 Winter Peak. This is the extent of the current SPP planning horizon. The wind farm was modeled as a single aggregate unit as seen by the transmission system. Individual wind turbine generators and the wind farm collector system were not explicitly modeled, as this detail is not needed in power flow analysis. The output of the wind farm was offset in each model by a reduction in output of existing online AEPW generation.

3.3 Power flow Analysis Results

Option 1: Point of interconnection on the 138 kV line 3 miles from Weatherford Tap

The summary list of limiting elements from FCITC analysis is shown in Table 1. Full FCITC results are in Appendix D.

Table 1. FCITC Thermal Results

Study Case	Incremental Transfer Capability	Limiting Element	TDF	Pre Transfer Loading	Rating	Contingency
05SP	130+	none				
05FA	9.0	55897 ELKCITY269.0 54122 ELKCTY-269.0 1	-0.04127	-38.2	38.5	56001 MORWODS4 138 99994 Gen-2002-005 138 1
05FA	45.4	55942 HM-BTTP269.0 56000 MORWODS269.0 1	-0.03679	-24.1	25.8	55999 MOORLND4 138 56001 MORWODS4 138 1
05WP	130+	none				
07SP	58.9	55942 HM-BTTP269.0 56000 MORWODS269.0 1	-0.03477	-23.5	25.6	55999 MOORLND4 138 56001 MORWODS4 138 1
07WP	102.5	55942 HM-BTTP269.0 56000 MORWODS269.0 1	-0.03597	-22.1	25.8	55999 MOORLND4 138 56001 MORWODS4 138 1
10SP	130+	none				
10WP	104.7	55942 HM-BTTP269.0 56000 MORWODS269.0 1	-0.03576	-22.1	25.8	55999 MOORLND4 138 56001 MORWODS4 138 1

The 69 kV lines (55897 ELKCITY269.0 54122 ELKCTY-269.0 1) and (55942 HM-BTTP269.0 56000 MORWODS269.0 1) were already overloaded in 2005 summer peak and winter peak base cases, and as such they are considered pre-existing problems.

Buses with voltage violations (above 1.1 pu or below 0.9 pu) in ACCC analysis were compared between the base cases and the corresponding cases with new generation interconnections. The only bus with voltage violations with the new wind farm that did not have violations in the base cases was due to an invalid contingency. All single contingencies in the area of study were automatically simulated. When using this automatic method, sometimes invalid contingencies are simulated. In this case, the 138 kV line from Iodine to Mooreland was tripped and voltage issues were seen at Iodine 138 kV bus due to switching of the Fort Supply 138/69 kV transformer taps. However, there is no 138 kV breaker separating the Iodine to Mooreland 138 kV line from the Iodine to Fort Supply 138 kV line, so both of these lines, the Iodine 138 kV bus, and the Iodine load would actually all trip together. Thus, the Iodine voltage is actually zero for this contingency both with and without the new wind farm. The Fort Supply 138/69 kV transformer is series connected to the Iodine to Fort Supply 138 kV line, and it is tripped as well. So no tap changing would take place. The key voltage to check for this contingency is at the Fort Supply 69 kV bus. This bus voltage stays within the required limits both with and without the new wind farm.

Option 2: Alternative point of interconnection - 4 miles to the east of the primary point of interconnection

The results of the Option 2 power flow analysis are similar to the Option 1 results.

The summary list of limiting elements from FCITC analysis is shown in Table 2. Full FCITC results are in Appendix D.

Table 2. FCITC Thermal Results – Alternative Interconnection Point

Study Case	Incremental Transfer Capability	Limiting Element	TDF	Pre Transfer Loading	Rating	Contingency
05SP	130+	none				
05FA	9.8	55897 ELKCITY269.0 54122 ELKCTY-269.0 1	-0.03773	-38.2	38.5	56001 MORWODS4 138 99994Gen-2002-005 138 1
05FA	50.6	55942 HM-BTTP269.0 56000 MORWODS269.0 1	-0.03301	-24.1	25.8	55999 MOORLND4 138 56001 MORWODS4 138 1
05WP	130+	none				
07SP	65.8	55942 HM-BTTP269.0 56000 MORWODS269.0 1	-0.03114	-23.5	25.6	55999 MOORLND4 138 56001 MORWODS4 138 1
07WP	112.3	55942 HM-BTTP269.0 56000 MORWODS269.0 1	-0.03234	-22.1	25.8	55999 MOORLND4 138 56001 MORWODS4 138 1
10SP	130+	none				
10WP	116.5	55942 HM-BTTP269.0 56000 MORWODS269.0 1	-0.03214	-22.1	25.8	55999 MOORLND4 138 56001 MORWODS4 138 1

The 69 kV lines (55897 ELKCITY269.0 54122 ELKCTY-269.0 1) and (55942 HM-BTTP269.0 56000 MORWODS269.0 1) are already overloaded in the 2005 summer peak and winter peak base cases and as such are considered pre-existing problems.

Buses with voltage violations (above 1.1 pu or below 0.9 pu) in ACCC analysis were compared between the base cases and the corresponding cases with new generation interconnections. The only bus with voltage violations with the new wind farm that did not have violations in the base cases was due to the same invalid contingency as discussed in wind farm location 1 above.

Since this is a preliminary Feasibility Study, not all previously queued projects were assumed to be in service in this Feasibility Study. If any of those projects are constructed, then this Feasibility Study will have to be revised to determine the impacts of this Interconnection Customer's project on transmission facilities. In accordance with FERC and SPP procedures the study cost for restudy shall be borne by the Interconnection Customer.

The costs included in this study do not include any costs associated with Network Resource (deliverability) of the energy to final customers. These costs are determined by separate studies when the Customer requests transmission service through Southwest Power Pool's OASIS. This cost if any will be presented in a subsequent study results.

The costs of interconnecting the facility to the transmission system are listed in Tables 3 and 4. These costs do not include any cost that might be associated with short circuit study results or dynamic stability study results. These costs will be determined when and if a System Impact Study is conducted.

Table 3: Network Upgrade Facilities

Facility	ESTIMATED COST (2004 DOLLARS)
Interconnection Three Breaker Ring Bus	\$2,275,000
Elk City to Elk City (Upgrade already Planned)	\$ 0
Morewood Switch to Hammon-Butler Jct. Transmission line and Line Switches on both ends	\$3,452,000
Total	\$5,727,000

Table 4: Direct Assignment Facilities

Facility	ESTIMATED COST (2004 DOLLARS)
Interconnection Facilities – Add 138kV bus, breaker, switches, metering, relaying, etc.	*
Customer – 138-34.5 kV Substation facilities.	*
Total	*

Note: * Estimates of cost to be determined by Customer.

4 STABILITY ANALYSIS

In this stability study, ABB investigated the stability of the system for faults in the vicinity of the proposed plant as defined by SPP. The faults involve three-phase and single-phase faults cleared by primary protection, reclosing with the fault still on, and then permanently clearing the fault by backup protection.

4.1 Stability Analysis Methodology

Using Planning Standards approved by NERC, the following stability definition was applied in the Transient Stability Analysis:

“Power system stability is defined as that condition in which the differences of the angular positions of synchronous machine rotors become constant following an aperiodic system disturbance.”

Stability analysis was performed using PTI's PSS/E dynamics program V28. GE wind generators were modeled using the latest (May 2004) GE wind turbine model available from PTI, modified with known data for the proposed wind farm.

Disturbances such as three phase and single-phase line faults were simulated for the specified durations, including reclosing, and the synchronous machine rotor angles were monitored to make sure they maintained synchronism following the fault removal.

Single-phase line faults were simulated with the standard method of applying a fault impedance to the positive sequence network to represent the effect of the negative and zero sequence networks on the positive sequence network. The fault impedance was computed to give a positive sequence voltage at the fault location of approximately 60% of pre-fault voltage, which is a typical value.

The ability of the wind generators to stay connected to the grid during the disturbances and during the fault recovery was also monitored. This is primarily determined by their low-voltage ride-through capabilities, or lack thereof, as represented in the models by low-voltage trip settings.

4.2 Study Model

The study model consists of a power flow case and dynamics database, developed as follows.

Power Flow Case

SPP provided a PSS/E power flow case called "05_GEN-2003-022_BASECASE.SAV". This case represents 2005 Summer Peak conditions on the SPP system.

The new Washita – Southwestern Station 138 kV line was added to the power flow case using an IDEV file provided by SPP. The resulting case was used as the base case for this study.

The developer provided a detailed layout of the wind farm collector system and wind turbine generators. While it is not practical to model 80 1.5 MW generators in power systems stability analysis, the detailed data was used to calculate a single machine equivalent for the 120 MW plant. The detailed plant was modeled in PSS/E power flow, and short-circuit analysis was used to determine the Thevenin equivalent impedance of the wind farm at the low side of the substation transformer. For aesthetic purposes, this impedance was separated into two parts, one an equivalent 0.575/34.5 kV, 140 MVA ($80 * 1.75$) GSU transformer, and the remainder representing an equivalent 34.5 kV collector system impedance¹.

Appendix B notes there was a Customer provided wind farm one-line diagram provided by SPP and equivalent model data for creation of an accurate study model.

Because PSS/E's DFIG model was to be used, the Wind Farm 120 MW generators were initially modeled at the GSU high-side bus (34.5 kV), and then the PTI IPLAN program was run to create the GSUs and

¹ An example of why this split is purely aesthetic is as follows: If the impedance of all the individual GSU transformers were to change, it would not be sufficient to simply change the impedance of the equivalent GSU transformer. One would need to change the individual GSU impedances in the detailed model and recalculate the Thevenin impedance. Subtracting out the new equivalent GSU impedance would leave a new and different equivalent collector system impedance. The only instance where one can expect the equivalent collector impedance to stay the same, when changing the GSUs is if all wind generators were identically distant in impedance from the substation, which is rarely the case.

move the generators to the low side (0.575 kV). The PSS/E DFIG default data were modified as necessary to match available data provided by the developer and the calculated equivalent.

The resulting PSS/E one-line diagram for the 120 MW case is shown below in Figure 3.

Stability Data

SPP provided the stability database in the form of a PSS/E dynamic raw data file “05sp_gen-2003-022_basecase.dyr” as well as IDEV and IPLAN files to compile and link user-written models. The provided files required the use of PSS/E version 28.

The latest PSS/E DFIG dynamic model was used to model the 120 MW wind farm. As mentioned above, the PSS/E DFIG model requires execution of an IPLAN program to create the GSUs and move the generators to the low-side (0.575 kV). This IPLAN program also generates a dynamic data file (*.dyr) for the DFIG machines. The direct dispatch (100.0%) for MW generation and voltage control mode for Mvar generation were used.

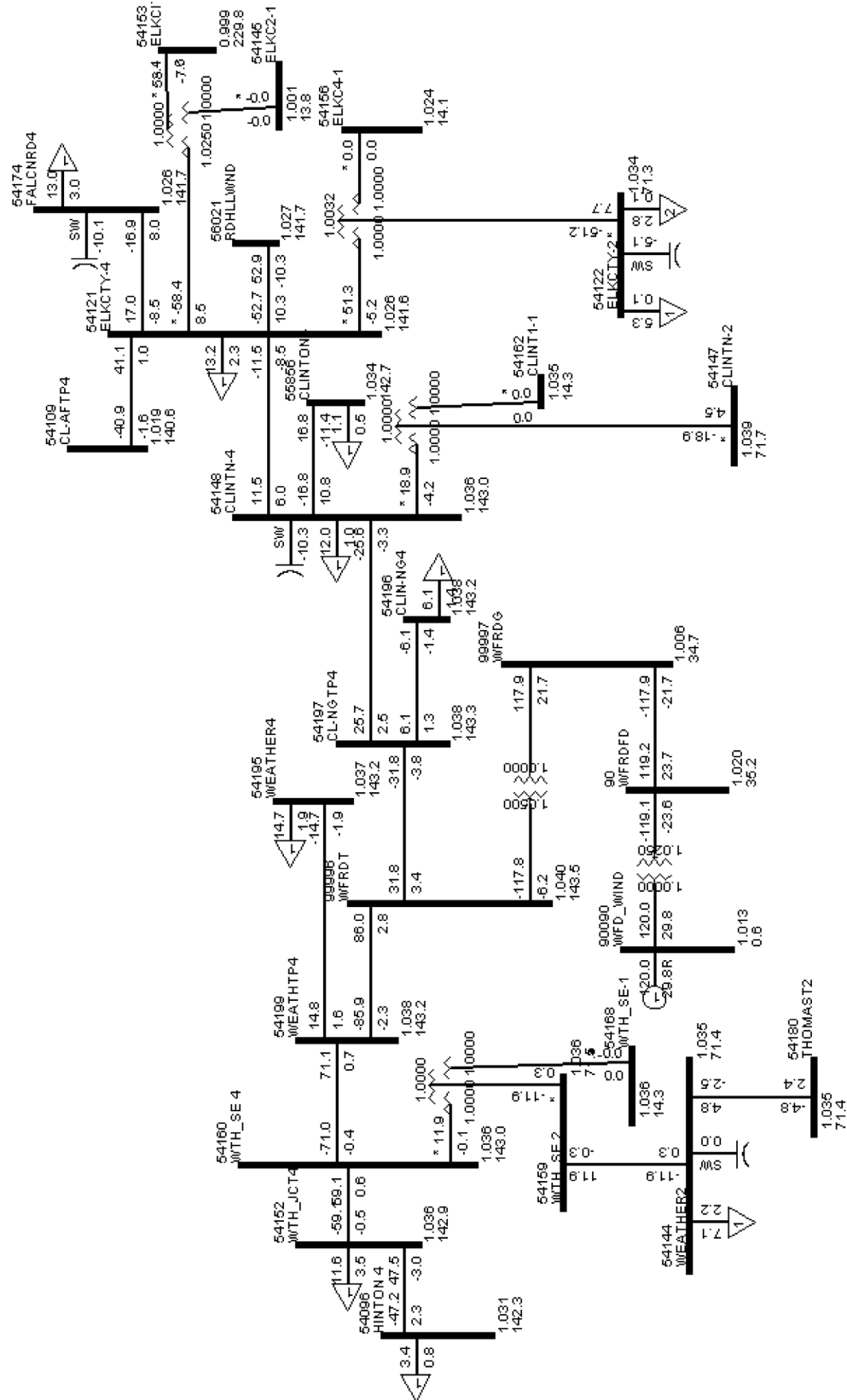

Figure 3. PSS/E One-line diagram of the Weatherford Area with Wind Farm at 120 MW

It is important to note that the PSS/E DFIG model includes under- and over-voltage and frequency trip relays in the model. The undervoltage settings are the most critical. The developer stated that the generators in their new wind farm will have ride-through capability for voltages below 15% for up to 500 msec. This is the latest and greatest ride-through capability available from GE Wind, and the dynamic model was adjusted to reflect this. The following voltage settings were used:

Table 5. DFIG Voltage Trip Settings

Undervoltage settings (per unit)	Time Delay (seconds)
0.15	0.5
0.75	1.0
0.85	10.0
Over-voltage settings (per unit)	
1.10	1.0
1.15	0.1
1.30	0.02

The *instantaneous (0.02 sec)* frequency trip models for the wind farm were disabled by changing the time delays to 10 seconds. PSS/E is not capable of calculating accurate frequencies during three-phase bolted fault conditions, and the wind farm would incorrectly trip during the fault.

Dynamic data for the equivalent 120 MW DFIG generator is shown in Appendix C.

Contingencies Tested

Fourteen three-phase and single-phase line faults were simulated on branches connected to Weatherford Junction, Weatherford SE, Clinton Junction, and Elk City 138 kV stations, as well as four faults at the proposed 138 kV wind farm interconnection station, for a total of 18 faults. It is assumed that the wind farm will be connected to the system via a 138 kV, 3-breaker ring bus. Figure 4 shows the fault locations on a one-line diagram of the area. Breaker locations are also shown. All transmission lines were assumed to have reclosing enabled, although reclosing should probably be turned off once the new wind farm comes on line. The complete fault descriptions are included with the results in Table 6.

4.3 STABILITY RESULTS

Results are tabulated in Table 6. As shown, the results indicate that the system is stable following all faults. In addition, the wind farm does not trip in any of the simulated fault scenarios, due to its 500 msec low-voltage ride-through capability.

The only issue is undervoltage tripping of the Gen-2002-005 Wind 120 MW generator during all 3-phase faults and one single-phase fault, but it also trips in the base case without the proposed wind farm. The reason that the Gen-2002-005 Wind generator trips is because low ride-through capability is not included in the provided model. The Gen-2002-005 Wind dynamic model trips the generator if the voltage goes below 70% for more than 80 msec. If the Gen-2002-005 wind farm is not yet installed, there may still be time to request better low-voltage ride-through capability for its wind turbine generators.

Currently GE 1.5 MW wind turbines have a 500 msec (30 cycle) ride-through capability for voltages less than 15%. They can also ride through voltages below 75% for 1 second and below 85% for 10 seconds. Three-phase faults #1 and #3, which include multiple reclosing events totaling 34.5 cycles (575 msec) of fault time, cause the voltage could go as low as 12% at the wind generator terminals every time a 3-phase fault is on at Weatherford Junction. Currently the PSS/E model does not consider cumulative low-voltage time caused by multiple reclosings, so the wind farm does not trip during those fault simulations. However, cumulative fault time in a short time span may indeed be important in determining true low-voltage ride-through capability. To study this phenomenon in detail, a three-phase electromagnetic transient study would be needed, along with more information from the wind turbine manufacturer.

Reclosing into 3-phase faults near the plant is also detrimental to the turbine shafts, independent of nominal mechanical speed. The problem is that electrical power and torque are slamming back and forth between approximately 1.0 per unit and 0 per unit, causing mechanical fatigue. If reclosing takes place when shaft oscillations are still persisting, the resultant torques on the shaft may be even more severe. Standard industry practice is to have no fast (<10s) reclosing on multi-phase faults near generating plants without detailed studies of shaft fatigue duty. Ultimately, ABB recommends no automatic line reclosing at the Wind Farm, Weatherford SE, Weatherford Junction, and Clinton Junction substations to prevent tripping of and/or damage to the wind turbines.

Simulation plots for all fault cases are shown in Appendix E.

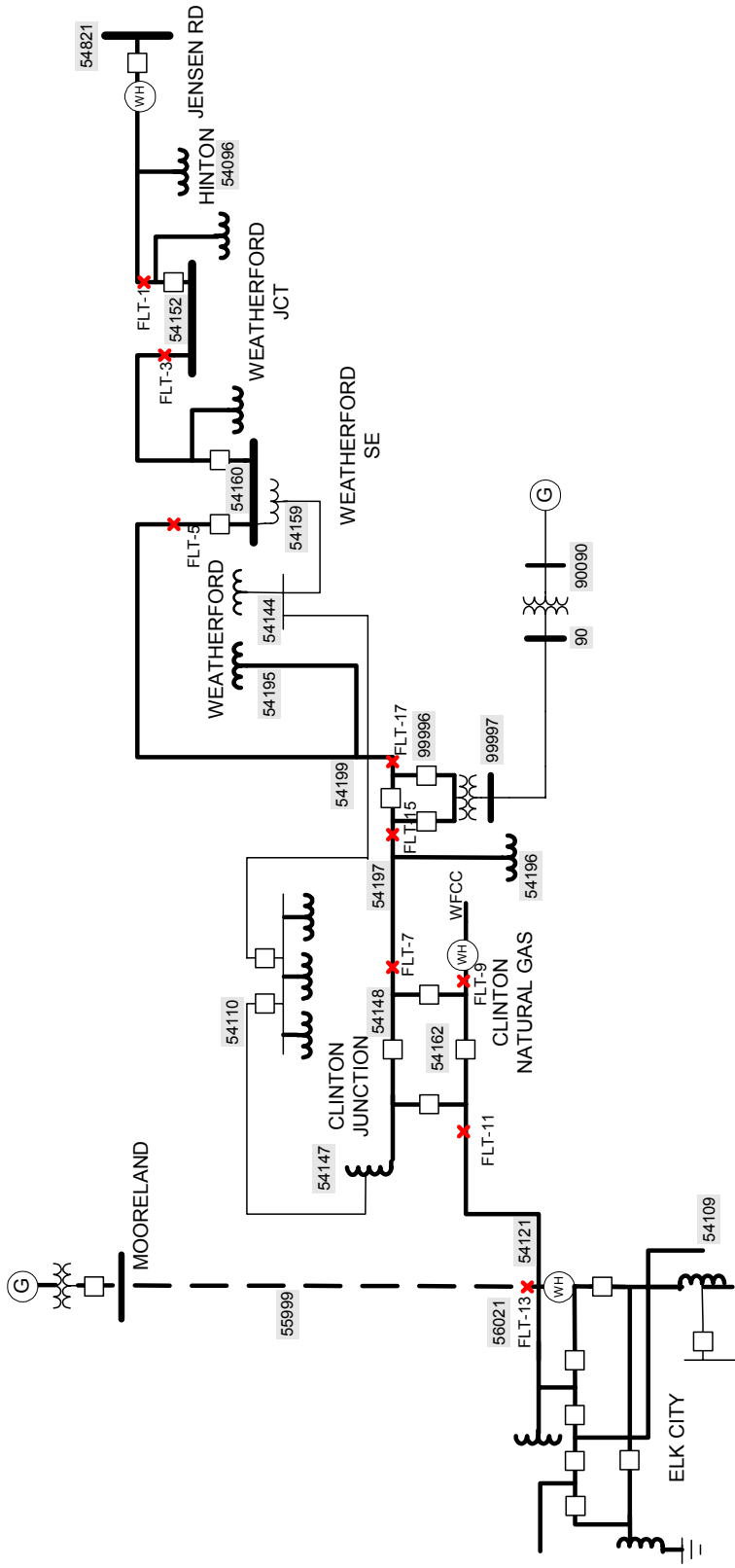

Figure 4. System One-line Showing Locations of Simulated Faults

Table 6. Fault Results with Wind Farm at 120 MW:

FAULT	FAULT DESCRIPTION	RESULTS
FLT1-3PH 3-phase Fault	1. Fault on Weatherford Junction (54152)- Jensen Road (54821), 138kV line, near Weatherford Junction.	STABLE (Undervoltage Trip at Gen-2002-005 Wind for cases with and without the new wind farm.)
	a. Apply fault at the Weatherford Junction (54152).	
	b. Clear fault after 3.5 cycles by removing the line from 54152 to 54821.	
	c. Use 3 shot re-closing at 6 cycles, 120 cycles, and 180 cycles for the line in (b) into the fault.	
FLT2-1PH 1-phase Fault	2. Fault on Weatherford Junction (54152)- Jensen Road (54821), 138kV line, near Weatherford Junction.	STABLE
	a. Apply fault at the Weatherford Junction (54152).	
	b. Clear fault after 3.5 cycles by removing the line from 54152 to 54821.	
	c. Use 3 shot re-closing at 6 cycles, 120 cycles, and 180 cycles for the line in (b) into the fault.	
FLT3-3PH 3-phase Fault	3. Fault on Weatherford Junction (54152)- Weatherford SE (54160), 138kV line, near Weatherford Junction.	STABLE (Undervoltage Trip at Gen-2002-005 Wind for cases with and without the new wind farm.)
	a. Apply fault at the Weatherford Junction (54152).	
	b. Clear fault after 3.5 cycles by removing the line from 55893 to 54160.	
	c. Use 3 shot re-closing at 6 cycles, 120 cycles, and 180 cycles for the line in (b) into the fault.	
FLT4-1PH 1-phase Fault	4. Fault on Weatherford Junction (54152)- Weatherford SE (54160), 138kV line, near Weatherford Junction.	STABLE
	a. Apply fault at the Weatherford Junction (54152).	
	b. Clear fault after 3.5 cycles by removing the line from 55893 to 54160.	
	c. Use 3 shot re-closing at 6 cycles, 120 cycles, and 180 cycles for the line in (b) into the fault.	
FLT5-3PH 3-phase Fault	5. Fault on Weatherford Junction SE (54160) – Gen-2003-022 Wind farm (99996), near Weatherford SE (54160).	STABLE (Undervoltage Trip at Gen-2002-005 Wind for cases with and without the new wind farm.)
	a. Apply fault at the Weatherford SE (54160).	
	b. Clear fault after 3.5 cycles by removing the line from 54160 to 99996.	
	c. Use 1 shot re-closing at 30 cycles for the line in (b) into the fault.	
FLT6-1PH 1-phase Fault	6. Fault on Weatherford Junction SE (54160) – Gen-2003-022 Wind farm (99996), near Weatherford SE (54160).	STABLE
	a. Apply fault at the Weatherford SE (54160).	
	b. Clear fault after 3.5 cycles by removing the line from 54160 to 99996.	
	c. Use 1 shot re-closing at 30 cycles for the line in (b) into the fault.	

FAULT	FAULT DESCRIPTION	RESULTS
FLT7-3PH 3-phase Fault	7. Fault on the Clinton Junction (54148) – Gen-2003-022 Wind farm (99996), near Clinton Junction (54148).	STABLE (Undervoltage Trip at Gen-2002-005 Wind for cases with and without the new wind farm.)
	a. Apply fault at the Clinton Junction (54148).	
	b. Clear fault after 3.5 cycles by removing the line from 54148 to 99996.	
	c. Use 1 shot re-closing at 30 cycles for the line in (b) into the fault.	
FLT8-1PH 1-phase Fault	8. Fault on the Clinton Junction (54148) – Gen-2003-022 Wind farm (99996), near Clinton Junction (54148).	STABLE
	a. Apply fault at the Clinton Junction (54148).	
	b. Clear fault after 3.5 cycles by removing the line from 54148 to 99996.	
	c. Use 1 shot re-closing at 30 cycles for the line in (b) into the fault.	
FLT9-3PH 3-phase Fault	9. Fault on the Clinton Junction (54148) – WFEC Washita (56089), 138 kV line, near Clinton Junction (54148).	STABLE (Undervoltage Trip at Gen-2002-005 Wind for cases with and without the new wind farm.)
	a. Apply fault at the Clinton Junction (54148).	
	b. Clear fault after 3.5 cycles by removing the line from 54148 to 55856.	
	c. Use 3 shot re-closing at 6 cycles, 120 cycles, and 180 cycles for the line in (b) into the fault.	
FLT10-1PH 1-phase Fault	10. Fault on the Clinton Junction (54148) – WFEC Washita (56089), 138 kV line, near Clinton Junction (54148).	STABLE
	a. Apply fault at the Clinton Junction (54148).	
	b. Clear fault after 3.5 cycles by removing the line from 54148 to 55856.	
	c. Use 3 shot re-closing at 6 cycles, 120 cycles, and 180 cycles for the line in (b) into the fault.	
FLT11-3PH 3-phase Fault	11. Fault on the Clinton Junction (54148) – Elk City (54121), 138 kV line, near Clinton Junction (54148).	STABLE (Undervoltage Trip at Gen-2002-005 Wind for cases with and without the new wind farm.)
	a. Apply fault at the Clinton Junction (54148).	
	b. Clear fault after 3.5 cycles by removing the line from 54148 to 54121.	
	c. Use 3 shot re-closing at 6 cycles, 120 cycles, and 180 cycles for the line in (b) into the fault.	
FLT12-1PH 1-phase Fault	12. Fault on the Clinton Junction (54148) – Elk City (54121), 138 kV line, near Clinton Junction (54148).	STABLE
	a. Apply fault at the Clinton Junction (54148).	
	b. Clear fault after 3.5 cycles by removing the line from 54148 to 54121.	
	c. Use 3 shot re-closing at 6 cycles, 120 cycles, and 180 cycles for the line in (b) into the fault.	

FAULT	FAULT DESCRIPTION	RESULTS
FLT13-3PH 3-phase Fault	13. Fault on the Elk City (54121) – Morewood (55999), 138kV line, near Elk City.	STABLE (Undervoltage Trip at Gen-2002-005 Wind for cases with and without the new wind farm.)
	a. Apply fault at the Elk City (54121).	
	b. Clear fault after 3.5 cycles by removing the line from 54121 to 56021.	
	c. Use 2 shot re-closing at 30 cycles and 120 cycles for the line in (b) into the fault.	
FLT14-1PH 1-phase Fault	14. Fault on the Elk City (54121) – Morewood (55999), 138kV line, near Elk City.	STABLE (Undervoltage Trip at Gen-2002-005 Wind for cases with and without the new wind farm.)
	a. Apply fault at the Elk City (54121).	
	b. Clear fault after 3.5 cycles by removing the line from 54121 to 56021.	
	c. Use 2 shot re-closing at 30 cycles and 120 cycles for the line in (b) into the fault.	
FLT15-3PH 3-phase Fault	15. Fault on the Gen-2003-022 (99996) – Clinton Junction (54197), 138kV line, Gen-2003-022.	STABLE (Undervoltage Trip at Gen-2002-005 Wind for cases with and without the new wind farm.)
	a. Apply fault at the Gen-2003-022 (99996).	
	b. Clear fault after 3.5 cycles by removing the line from 99996 to 54197.	
	c. Use 1 shot re-closing at 30 cycles for the line in (b) into the fault.	
FLT16-1PH 1-phase Fault	16. Fault on the Gen-2003-022 (99996) – Clinton Junction (54197), 138kV line, Gen-2003-022.	STABLE
	a. Apply fault at the Gen-2003-022 (99996).	
	b. Clear fault after 3.5 cycles by removing the line from 99996 to 54197.	
	c. Use 1 shot re-closing at 30 cycles for the line in (b) into the fault.	
FLT17-3PH 3-phase Fault	17. Fault on the Gen-2003-022 (99996) – Weatherford Junction (54199), 138kV line, Gen-2003-022.	STABLE (Undervoltage Trip at Gen-2002-005 Wind for cases with and without the new wind farm.)
	a. Apply fault at the Gen-2003-022 (99996).	
	b. Clear fault after 3.5 cycles by removing the line from 99996 to 54199.	
	c. Use 1 shot re-closing at 30 cycles for the line in (b) into the fault.	
FLT18-1PH 1-phase Fault	18. Fault on the Gen-2003-022 (99996) – Weatherford Junction (54199), 138kV line, Gen-2003-022.	STABLE
	a. Apply fault at the Gen-2003-022 (99996).	
	b. Clear fault after 3.5 cycles by removing the line from 99996 to 54199.	
	c. Use 1 shot re-closing at 30 cycles for the line in (b) into the fault.	

5 STUDY CONCLUSIONS

The power flow analysis showed that there was no thermal overloading of lines due to proposed plant, when considering only lines with OTDF above 3%. If OTDFs below 3% are considered, a few lines are adversely impacted by the wind farm. The few problems are either pre-existing or have extremely low response to the new power injection from the plant.

There are no new voltage violations due to the new wind farm in the studied cases.

Based on the results of the stability analysis, it is concluded that the wind farm at 120 MW does not adversely impact the stability of the SPP system. It is recommended that automatic reclosing be disabled on transmission lines adjacent to the wind farm to protect the wind turbine generators from tripping or undue stress from reclosing into faults. In addition, low-voltage ride-through capability should be considered for the Gen-2002-005 wind farm, to avoid unnecessary and nuisance tripping of its 120 MW of generation following transmission faults.

The results of this analysis are based on available data and assumptions made at the time of conducting this study. If any of the data and/or assumptions made in developing the study model change, the results provided in this report may not apply.

APPENDIX A – POWER FLOW SIMULATION SETTINGS

Appendix A.1 (PSS/E)

PSS/E CHOICES IN RUNNING LOAD FLOW PROGRAM AND ACCC

BASE CASES:

Solutions – Fixed slope decoupled Newton-Raphson solution (FDNS)

1. Tap adjustment – Stepping
2. Area interchange control – Tie lines only
3. Var limits – Apply immediately
4. Solution options - Phase shift adjustment
 - Flat start
 - Lock DC taps
 - Lock switched shunts

ACCC CASES:

Solutions – AC contingency checking (ACCC)

1. MW mismatch tolerance – 0.5
2. Contingency case rating – Rate B
3. Percent of rating – 100
4. Output code – Summary
5. Min flow change in overload report – 1mw
6. Exclude cases w/ no overloads form report – YES
7. Exclude interfaces from report – NO
8. Perform voltage limit check – YES
9. Elements in available capacity table – 60000
10. Cutoff threshold for available capacity table – 99999.0
11. Minimum contingency case voltage change for report – 0.02
12. Sorted output – None

Newton Solution:

1. Tap adjustment – Stepping
2. Area interchange control – Tie lines only
3. Var limits – Apply automatically
4. Solution options - Phase shift adjustment
 - Flat start
 - Lock DC taps
 - Lock switched shunts

Appendix A.2 (MUST)

MUST CHOICES IN RUNNING FCITC DC ANALYSIS

CONSTRAINTS/CONTINGENCY INPUT OPTIONS

1. AC Mismatch Tolerance – 2 MW
2. Base Case Rating – Rate A
3. Base Case % of Rating – 100%
4. Contingency Case Rating – Rate B
5. Contingency Case % of Rating – 100%
6. Base Case Load Flow – PSS/E
7. Convert branch ratings to estimated MW ratings – Yes
8. Contingency ID Reporting – Labels
9. Maximum number of contingencies to process - 50000

MUST CALCULATION OPTIONS

1. Phase Shifters Model for DC Linear Analysis – Constant flow for Base Case and Contingencies
2. Report Base Case Violations with FCITC – Yes
3. Maximum number of violations to report in FCITC table - 50000
4. Distribution Factor (OTDF and PTDF) Cutoff – 0.03
5. Maximum times to report the same elements - 10
6. Apply Distribution Factor to Contingency Analysis – Yes
7. Apply Distribution Factor to FCITC Reports – Yes
8. Minimum Contingency Case flow change – 1 MW
9. Minimum Contingency Case Distribution Factor change – 0.0
10. Minimum Distribution Factor for Transfer Sensitivity Analysis – 0.0

APPENDIX B – COLLECTOR SYSTEM

Customer provided detailed One-Line for creation of model

Substation Main Transformer data:

138-34.5 kV 81/108/135 MVA
YG-Delta Buried-YG

Z @ 81MVA base.

Z+
H-X 8.9%
H-Y 14.0%
X-Y 3.9%

Z0
H-X 7.5%
H-Y 10.8%
X-Y 3.3%

Collector system Equivalent:

R = 0.009336
X = 0.01346

GSU Equivalent:

0.575 – 34.5 kV, 1.750 MVA * 80 = 140 MVA
5.87% impedance @ 140 MVA

**APPENDIX C - STABILITY MODEL PARAMETERS
FOR WIND FARM**

PSS/E Dynamic Data for Equivalent DFIG Generator Modeling 120 MW

PTI INTERACTIVE POWER SYSTEM SIMULATOR--PSS/E THU, MAY 20 2004 16:03
 SPP MDWG 04 STABILITY;2005 SUMMER PEAK;S05SP-28.CNL;3-12-04
 (C) 2004 SOUTHWEST POWER POOL, INC. (SEE DISCLAIMER BELOW)

PLANT MODELS

REPORT FOR ALL MODELS BUS 90090 [WFD_WIND0.5750] MODELS

THE DFIGPQ6.FOR MODEL, RELEASE # 03, WAS UPDATED ON MARCH 03, 2004

```

** DFIGPQ ** BUS X-- NAME --X BASEKV MC C O N S S T A T E S VAR ICON
          90090 WFD_WIND 0.5750 1 222025-222032 82596-82597 15416-15433 6793

RA LA LM R1 L1 H DAMP
0.0071 0.1714 2.9040 0.0050 0.1563 0.6200 0.0000

-SLIP
0.2000
    
```

THE CGECN5.FOR MODEL, RELEASE # 01, WAS UPDATED ON MARCH 08, 2004

```

** CGECN2 for DFIGPQ ** BUS X-- NAME --X BASEKV MC C O N S S T A T E S VAR
ICON
          90090 WFD_WIND 0.5750 1 222033-222049 82598-82603 15434-15438
6794-6796

TFV KPV KIV RC XC TFP KPP
0.0200 0.0000 62.5580 0.0000 0.0000 0.0500 3.0000

KIP PMX PMN QMX QMN IMAX TRV
0.6000 0.9100 0.0900 0.4690 -0.4690 1.1100 0.0500

RPMX RPMN T_POWER
0.4500 -0.4500 5.0000
    
```

PTI INTERACTIVE POWER SYSTEM SIMULATOR--PSS/E THU, MAY 20 2004 16:03
 SPP MDWG 04 STABILITY;2005 SUMMER PEAK;S05SP-28.CNL;3-12-04
 (C) 2004 SOUTHWEST POWER POOL, INC. (SEE DISCLAIMER BELOW)

CONEC MODELS

REPORT FOR ALL MODELS BUS 90090 [WFD_WIND0.5750] MODELS

*** CALL TWIND1 (6797,222050, 0, 15439) ***

THE TWIND1.FOR MODEL, RELEASE # 02, WAS UPDATED ON FEBRUARY 24, 2004

```

** TWIND1 ** BUS X-- NAME --X BASEKV MC C O N S V A R S ICONS
          90090 WFD_WIND 0.5750 1 222050-222056 15439-15441 6797-6798

VWB T1G TG MAXG T1R T2R MAXR
12.0009999.000 5.000 30.0009999.0009999.000 30.000

Wind generator Bus # 90090
Wind Generator ID 1
    
```



THE TSHAFT2.FOR MODEL, RELEASE # 02, WAS UPDATED ON FEBRUARY 24, 2004

```

** TSHAFT for a machine **  BUS X-- NAME --X BASEKV MC   C O N S           STATE           VAR
ICON
          90090      WFD_WIND 0.5750 1   222057-222061   82604-82605   15442-15444
6799-6801

          D12          K12          Ta1          p          Rq
          1.5000        1.1150        8.6400        3.0000       72.0000
    
```

```

Wind Generator Bus # 90090
Wind Generator ID   1
    
```

THE GEAERO1.FOR MODEL, RELEASE # 01, WAS DEVELOPED ON FEBRUARY 25, 2004

```

** GEAERO for DFIGPQ **   BUS X-- NAME --X BASEKV MC   C O N S           STATE           VAR
ICON
          90090      WFD_WIND 0.5750 1   222062-222073   82606-82606   15445-15448
6802-6804

VWinit      Lambda_Max      Lambda_Min      PITCH_MAX      PITCH_MIN      Ta
12.0000      20.0000          0.0000          27.0000        -4.0000         0.5000

RHO          Radius          GB_RATIO        SYNCHR          Power_Rate      MBASE1
1.2250       35.2500          72.0000         1200.0          1500.0          1.6670
    
```

```

Wind Generator Bus # 90090
Wind Generator ID   1
    
```

THE TGPTCH1.FOR MODEL, RELEASE # 02, WAS UPDATED ON FEBRUARY 24, 2004

```

** TGPTCH for DFIGPQ **  BUS X-- NAME --X BASEKV MC   C O N S           STATE           VAR
ICON
          90090      WFD_WIND 0.5750 1   222074-222083   82607-82609   15449-15451
6805-6807

Tp          Kpp          Kip          Kpc          Kic
0.2000     150.0000    25.0000     1.0000       3.0000
TetaMin    TetaMax     RTetaMin    RTetaMax     PMX
-4.0000    27.0000    -10.0000    10.0000     0.9100
    
```

```

Wind Generator Bus # 90090
Wind Generator ID   1
    
```

PTI INTERACTIVE POWER SYSTEM SIMULATOR--PSS/E THU, MAY 20 2004 16:03
 SPP MDWG 04 STABILITY;2005 SUMMER PEAK;S05SP-28.CNL;3-12-04
 (C) 2004 SOUTHWEST POWER POOL, INC. (SEE DISCLAIMER BELOW)

CONET MODELS

REPORT FOR ALL MODELS BUS 90090 [WFD_WIND0.5750] MODELS

THE VTGTRP.FLX MODEL, RELEASE # 02, WAS UPDATED ON FEBRUARY 24, 2004

```

*** CALL VTGTRP( 6808,222084, 0, 15452) ***

BUS  NAME BSKV      GENR BUS  NAME BSKV
90090 WFD_WIND.575  90090 WFD_WIND.575

I C O N S          C O N S          V A R
6808-6812      222084-222087   15452

VLO          VUP          PICKUP      TB
0.150        5.000        0.500       0.150
    
```

THE VTGTRP.FLX MODEL, RELEASE # 02, WAS UPDATED ON FEBRUARY 24, 2004

```

*** CALL VTGTRP( 6813,222088,    0, 15453) ***

BUS  NAME  BSKV      GENR BUS  NAME  BSKV
90090 WFD_WIND.575      90090 WFD_WIND.575

  I C O N S      C O N S      V A R
  6813-6817      222088-222091      15453

  VLO      VUP      PICKUP      TB
  0.750    5.000    1.000      0.150

```

THE VTGTRP.FLX MODEL, RELEASE # 02, WAS UPDATED ON FEBRUARY 24, 2004

```

*** CALL VTGTRP( 6818,222092,    0, 15454) ***

BUS  NAME  BSKV      GENR BUS  NAME  BSKV
90090 WFD_WIND.575      90090 WFD_WIND.575

  I C O N S      C O N S      V A R
  6818-6822      222092-222095      15454

  VLO      VUP      PICKUP      TB
  0.850    5.000    10.000     0.150

```

THE VTGTRP.FLX MODEL, RELEASE # 02, WAS UPDATED ON FEBRUARY 24, 2004

```

*** CALL VTGTRP( 6823,222096,    0, 15455) ***

BUS  NAME  BSKV      GENR BUS  NAME  BSKV
90090 WFD_WIND.575      90090 WFD_WIND.575

  I C O N S      C O N S      V A R
  6823-6827      222096-222099      15455

  VLO      VUP      PICKUP      TB
  0.000    1.100    1.000      0.150

```

THE VTGTRP.FLX MODEL, RELEASE # 02, WAS UPDATED ON FEBRUARY 24, 2004

```

*** CALL VTGTRP( 6828,222100,    0, 15456) ***

BUS  NAME  BSKV      GENR BUS  NAME  BSKV
90090 WFD_WIND.575      90090 WFD_WIND.575

  I C O N S      C O N S      V A R
  6828-6832      222100-222103      15456

  VLO      VUP      PICKUP      TB
  0.000    1.150    0.100      0.150

```

THE VTGTRP.FLX MODEL, RELEASE # 02, WAS UPDATED ON FEBRUARY 24, 2004

```

*** CALL VTGTRP( 6833,222104,    0, 15457) ***

BUS  NAME  BSKV      GENR BUS  NAME  BSKV
90090 WFD_WIND.575      90090 WFD_WIND.575

  I C O N S      C O N S      V A R
  6833-6837      222104-222107      15457

  VLO      VUP      PICKUP      TB
  0.000    1.300    0.020      0.150

```

THE FRQTRP1.FLX MODEL, RELEASE # 03, WAS UPDATED ON FEBRUARY 25, 2004

```

*** CALL FRQTRP( 6838,222108,    0, 15458) ***

  BUS   NAME   BSKV   GEN BUS   NAME   BSKV   ID
90090  WFD_WIND .575   90090  WFD_WIND .575   1

      I C O N S       C O N S       V A R
      6838-6843     222108-222111  15458

      FLO      FUP      PICKUP    TB
      56.500   66.000   10.020    0.150

```

THE FRQTRP1.FLX MODEL, RELEASE # 03, WAS UPDATED ON FEBRUARY 25, 2004

```

*** CALL FRQTRP( 6844,222112,    0, 15459) ***

  BUS   NAME   BSKV   GEN BUS   NAME   BSKV   ID
90090  WFD_WIND .575   90090  WFD_WIND .575   1

      I C O N S       C O N S       V A R
      6844-6849     222112-222115  15459

      FLO      FUP      PICKUP    TB
      57.500   66.000   10.000    0.150

```

THE FRQTRP1.FLX MODEL, RELEASE # 03, WAS UPDATED ON FEBRUARY 25, 2004

```

*** CALL FRQTRP( 6850,222116,    0, 15460) ***

  BUS   NAME   BSKV   GEN BUS   NAME   BSKV   ID
90090  WFD_WIND .575   90090  WFD_WIND .575   1

      I C O N S       C O N S       V A R
      6850-6855     222116-222119  15460

      FLO      FUP      PICKUP    TB
      54.000   61.500   30.000    0.150

```

THE FRQTRP1.FLX MODEL, RELEASE # 03, WAS UPDATED ON FEBRUARY 25, 2004

```

*** CALL FRQTRP( 6856,222120,    0, 15461) ***

  BUS   NAME   BSKV   GEN BUS   NAME   BSKV   ID
90090  WFD_WIND .575   90090  WFD_WIND .575   1

      I C O N S       C O N S       V A R
      6856-6861     222120-222123  15461

      FLO      FUP      PICKUP    TB
      54.000   62.500   10.020    0.150

```

APPENDIX D – COMPLETE POWER FLOW RESULTS

Study Case	Incremental Transfer Capability	Limiting Element	TDF	Pre Transfer Loading	Rating	Contingency
2005						
05FA	9	55897 ELKCITY269.0 54122 ELKCTY-269.0 1	-0.04127	-38.2	38.5	56001 MORWODS4 138 99994 GEN-2002-005 138 1
05FA	45.4	55942 HM-BTTP269.0 56000 MORWODS269.0 1	-0.03679	-24.1	25.8	55999 MOORLND4 138 56001 MORWODS4 138 1
05FA-ALT	9.8	55897 ELKCITY269.0 54122 ELKCTY-269.0 1	-0.03773	-38.2	38.5	56001 MORWODS4 138 99994 GEN-2002-005 138 1
05FA-ALT	50.6	55942 HM-BTTP269.0 56000 MORWODS269.0 1	-0.03301	-24.1	25.8	55999 MOORLND4 138 56001 MORWODS4 138 1
05SP	-176.4	55897 ELKCITY269.0 54122 ELKCTY-269.0 1	-0.04127	-46.2	38.9	56001 MORWODS4 138 99994 GEN-2002-005 138 1
05SP	-34.6	55942 HM-BTTP269.0 56000 MORWODS269.0 1	-0.03584	-26.3	25.1	55999 MOORLND4 138 56001 MORWODS4 138 1
05SP	52.9	55897 ELKCITY269.0 54122 ELKCTY-269.0 1	-0.03101	-37.3	38.9	56000 MORWODS269.0 56001 MORWODS4 138 1
05SP-ALT	-193	55897 ELKCITY269.0 54122 ELKCTY-269.0 1	-0.03773	-46.2	38.9	56001 MORWODS4 138 99994 GEN-2002-005 138 1
05SP-ALT	-38.7	55942 HM-BTTP269.0 56000 MORWODS269.0 1	-0.03206	-26.3	25.1	55999 MOORLND4 138 56001 MORWODS4 138 1
05WP-ALT	-152.6	55897 ELKCITY269.0 54122 ELKCTY-269.0 1	-0.03773	-44.4	38.7	56001 MORWODS4 138 99994 GEN-2002-005 138 1
05WP-ALT	-119.6	55942 HM-BTTP269.0 56000 MORWODS269.0 1	-0.03212	-29.1	25.3	55999 MOORLND4 138 56001 MORWODS4 138 1
05WP	-139.5	55897 ELKCITY269.0 54122 ELKCTY-269.0 1	-0.04128	-44.4	38.7	56001 MORWODS4 138 99994 GEN-2002-005 138 1
05WP	-107.1	55942 HM-BTTP269.0 56000 MORWODS269.0 1	-0.0359	-29.1	25.3	55999 MOORLND4 138 56001 MORWODS4 138 1
05WP	114.6	55897 ELKCITY269.0 54122 ELKCTY-269.0 1	-0.031	-35.1	38.7	56000 MORWODS269.0 56001 MORWODS4 138 1
2007						
07SP	-146.3	55897 ELKCITY269.0 54122 ELKCTY-269.0 1	-0.04019	-44.9	39	56001 MORWODS4 138 99994 GEN-2002-005 138 1
07SP	45.6	55897 ELKCITY269.0 54122 ELKCTY-269.0 1	-0.03039	-37.6	39	56000 MORWODS269.0 56001 MORWODS4 138 1
07SP	58.9	55942 HM-BTTP269.0 56000 MORWODS269.0 1	-0.03477	-23.5	25.6	55999 MOORLND4 138 56001 MORWODS4 138 1
07SP-ALT	-159.9	55897 ELKCITY269.0 54122 ELKCTY-269.0 1	-0.03678	-44.9	39	56001 MORWODS4 138 99994 GEN-2002-005 138 1
07SP-ALT	65.8	55942 HM-BTTP269.0 56000 MORWODS269.0 1	-0.03114	-23.5	25.6	55999 MOORLND4 138 56001 MORWODS4 138 1
07WP	102.5	55942 HM-BTTP269.0 56000 MORWODS269.0 1	-0.03597	-22.1	25.8	55999 MOORLND4 138 56001 MORWODS4 138 1
07WP-ALT	112.3	55942 HM-BTTP269.0 56000 MORWODS269.0 1	-0.03234	-22.1	25.8	55999 MOORLND4 138 56001 MORWODS4 138 1
2010						
10WP	104.7	55942 HM-BTTP269.0 56000 MORWODS269.0 1	-0.03576	-22.1	25.8	55999 MOORLND4 138 56001 MORWODS4 138 1
10WP-ALT	116.5	55942 HM-BTTP269.0 56000 MORWODS269.0 1	-0.03214	-22.1	25.8	55999 MOORLND4 138 56001 MORWODS4 138 1

APPENDIX E – STABILITY PLOTS



SPP MDWG 04 STABILITY;2005 SUMMER PEAK;S05SP-28.CNL;3-12-04
(C) 2004 SOUTHWEST POWER POOL, INC. (SEE DISCLAIMER BELOW)

FILE: FLT13PH.out

0.25000	CHNL# 409: [SPD 90090 [WFD WIND0.5750] [1]]	X-----X	0.19000
1.5000	CHNL# 411: [VARS 90090 [WFD WIND0.5750] [1]]	+-----+	0.0
1.5000	CHNL# 410: [POWR 90090 [WFD WIND0.5750] [1]]	◇-----◇	0.0
1.5000	CHNL# 406: [VOLT 90090 [WFD WIND0.5750]]	←-----→	0.0
1.5000	CHNL# 403: [VOLT 99996 [WFRDT 138.00]]	▣-----▣	0.0

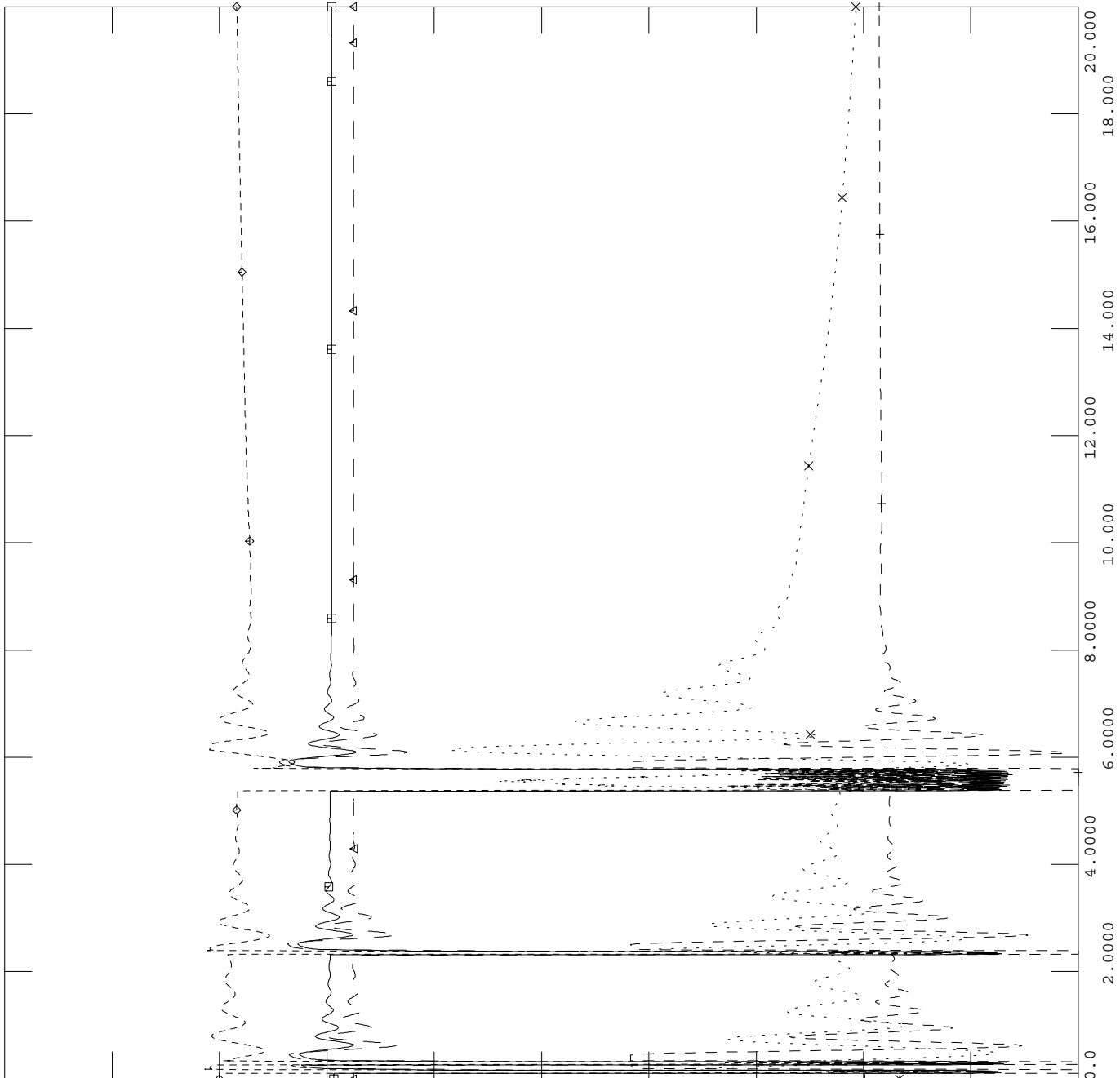

TUE, JUN 08 2004 16:47
NEW WIND GENERATOR

TIME (SECONDS)



SPP MDWG 04 STABILITY;2005 SUMMER PEAK;S05SP-28.CNL;3-12-04
(C) 2004 SOUTHWEST POWER POOL, INC. (SEE DISCLAIMER BELOW)

FILE: FLT13PH.out

0.00150	CHNL# 402: [SPD 55997 [MORLND2 18.000] [1]]	x-----x	-0.0010
0.04000	CHNL# 401: [SPD 56007 [GEN-02-005 34.50] [1]	+-----+	-0.0100
0.02000	CHNL# 400: [SPD 56103 [GEN-03-005 138.00] [2]	◇-----◇	0.01000
0.02000	CHNL# 399: [SPD 56103 [GEN-03-004 138.00] [1]	←-----→	0.01000
0.20150	CHNL# 398: [SPD 55787 [GEN-03-022 0.5750] [1]	□-----□	0.19900

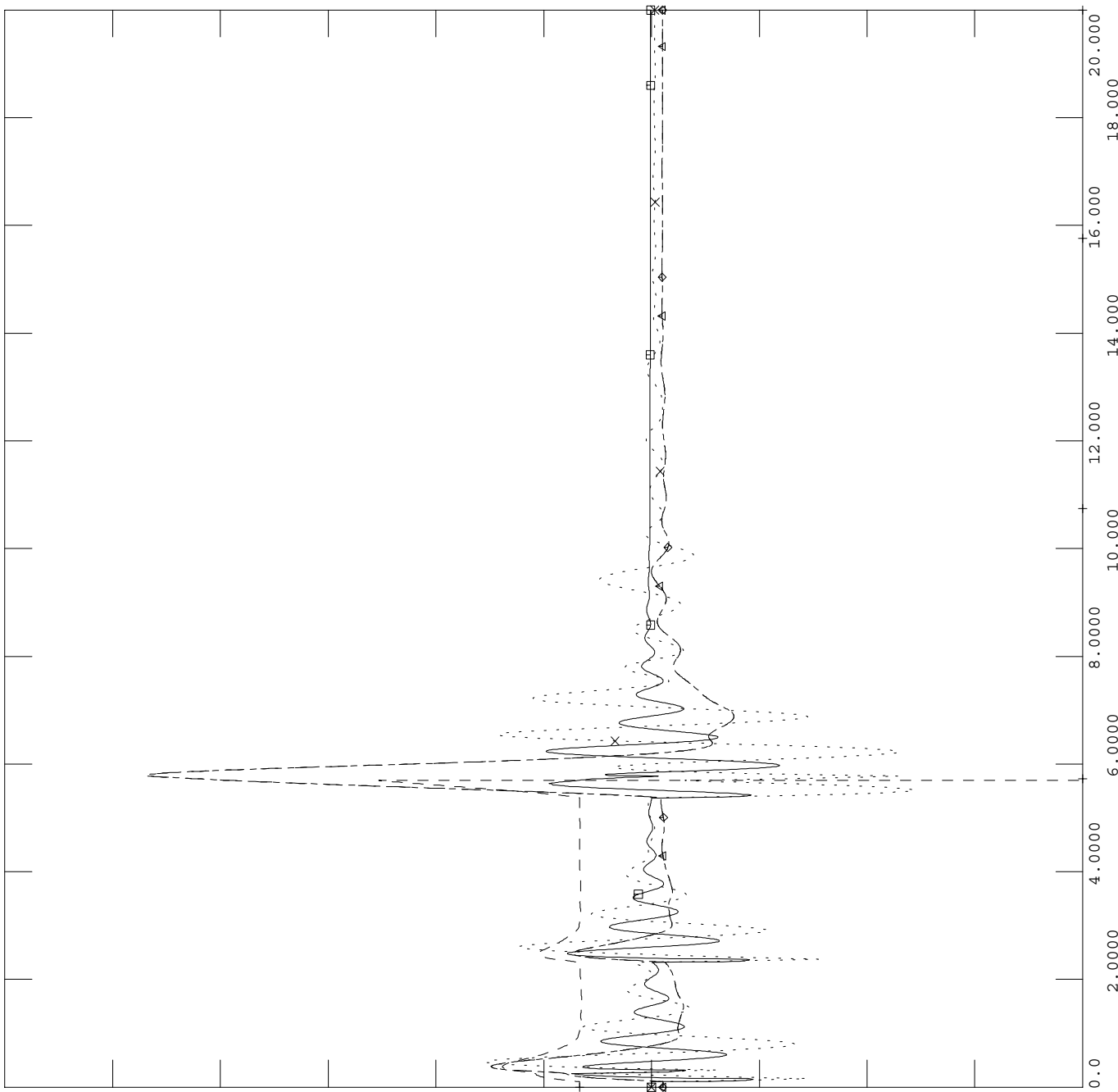

TUE, JUN 08 2004 16:47
OTHER GENERATOR SPEEDS



FILE: FLT21PH.out

0.25000	CHNL# 409: [SPD 90090 [WFD WIND0.5750] [1]]	x-----x	0.19000
1.5000	CHNL# 411: [VARS 90090 [WFD WIND0.5750] [1]]	+-----+	0.0
1.5000	CHNL# 410: [POWR 90090 [WFD WIND0.5750] [1]]	◇-----◇	0.0
1.5000	CHNL# 406: [VOLT 90090 [WFD WIND0.5750]]	←-----→	0.0
1.5000	CHNL# 403: [VOLT 99996 [WFRDT 138.00]]	▣-----▣	0.0

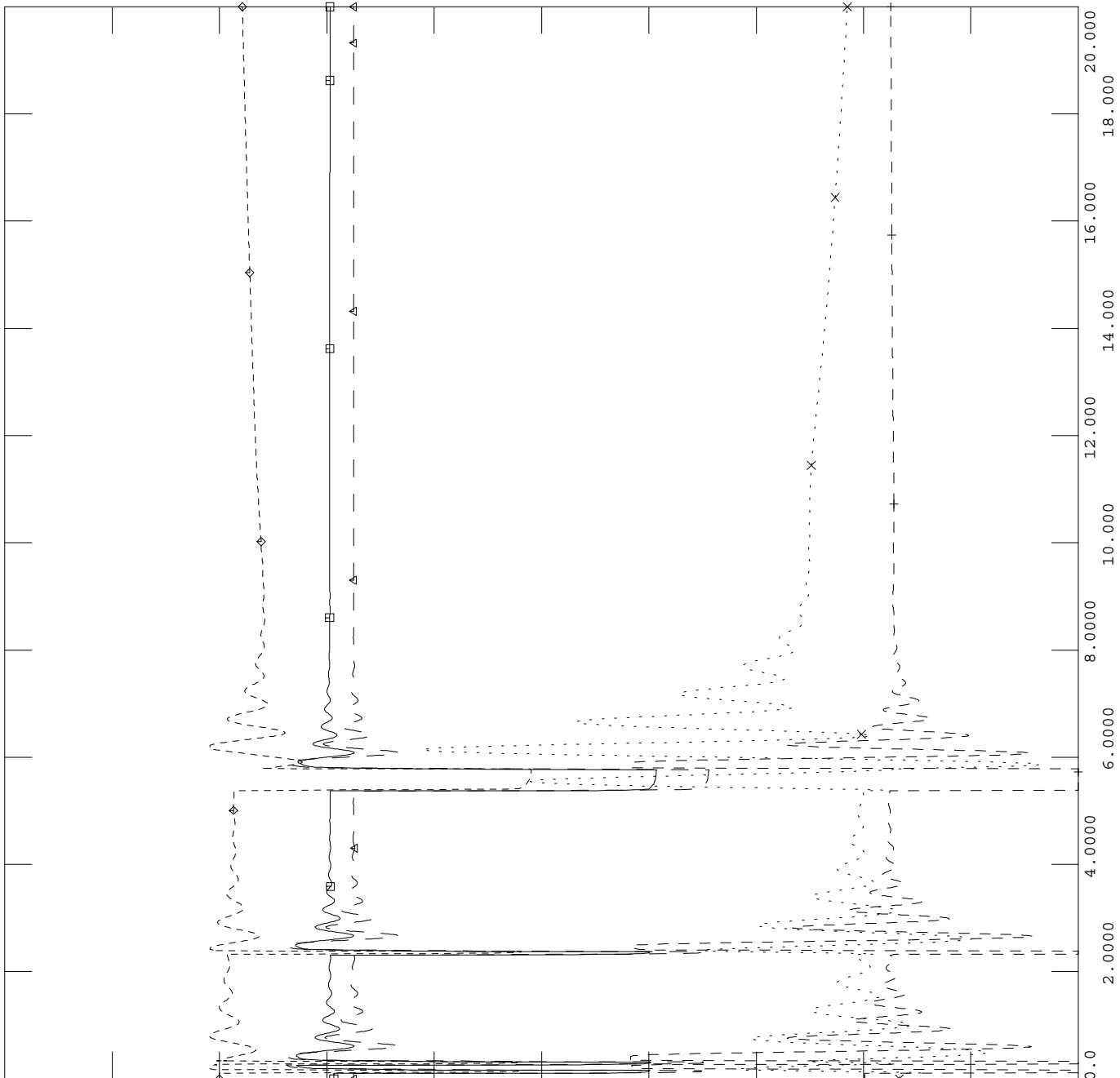

TUE, JUN 08 2004 16:47
NEW WIND GENERATOR

TIME (SECONDS)



SPP MDWG 04 STABILITY;2005 SUMMER PEAK;S05SP-28.CNL;3-12-04
(C) 2004 SOUTHWEST POWER POOL, INC. (SEE DISCLAIMER BELOW)

FILE: FLT21PH.out

0.00150	CHNL# 402: [SPD 55997 [MORLND2 18.000] [1]]	x-----x	-0.0010
0.04000	CHNL# 401: [SPD 56007 [GEN-02-005 34.50] [1]	+-----+	-0.0100
0.02000	CHNL# 400: [SPD 56103 [GEN-03-005 138.00] [2]	◇-----◇	0.01000
0.02000	CHNL# 399: [SPD 56103 [GEN-03-004 138.00] [1]	←-----→	0.01000
0.20150	CHNL# 398: [SPD 55787 [GEN-03-022 0.5750] [1]	□-----□	0.19900

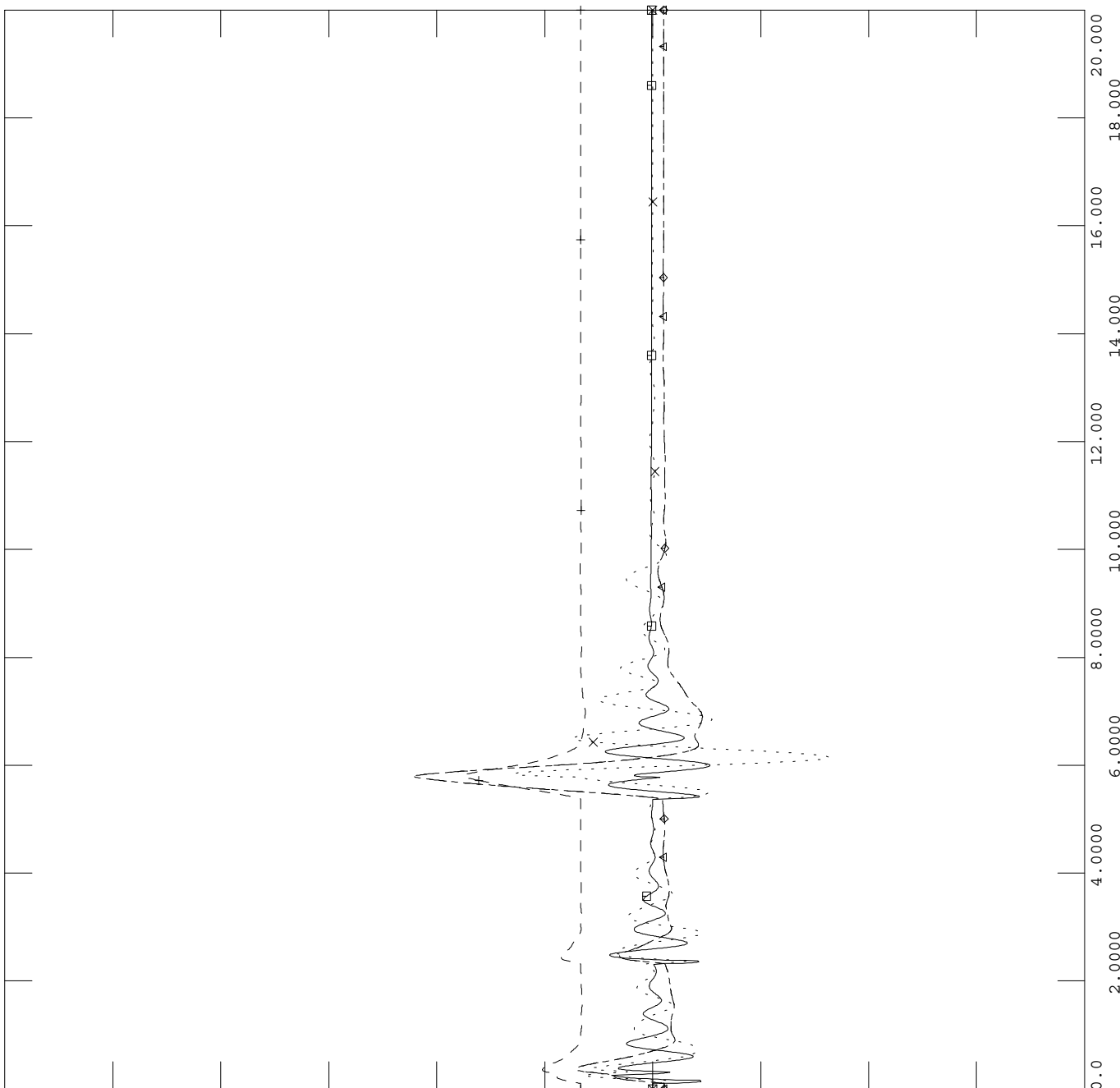

TUE, JUN 08 2004 16:47
OTHER GENERATOR SPEEDS



SPP MDWG 04 STABILITY;2005 SUMMER PEAK;S05SP-28.CNL;3-12-04
(C) 2004 SOUTHWEST POWER POOL, INC. (SEE DISCLAIMER BELOW)

FILE: FLT33PH.out

TUE, JUN 08 2004 16:47
NEW WIND GENERATOR

0.25000	CHNL# 409: [SPD 90090 [WFD WIND0.5750] [1]]	x-----x	0.19000
1.5000	CHNL# 411: [VARS 90090 [WFD WIND0.5750] [1]]	+-----+	0.0
1.5000	CHNL# 410: [POWR 90090 [WFD WIND0.5750] [1]]	o-----o	0.0
1.5000	CHNL# 406: [VOLT 90090 [WFD WIND0.5750]]	l-----r	0.0
1.5000	CHNL# 403: [VOLT 99996 [WFRDT 138.00]]	o-----o	0.0

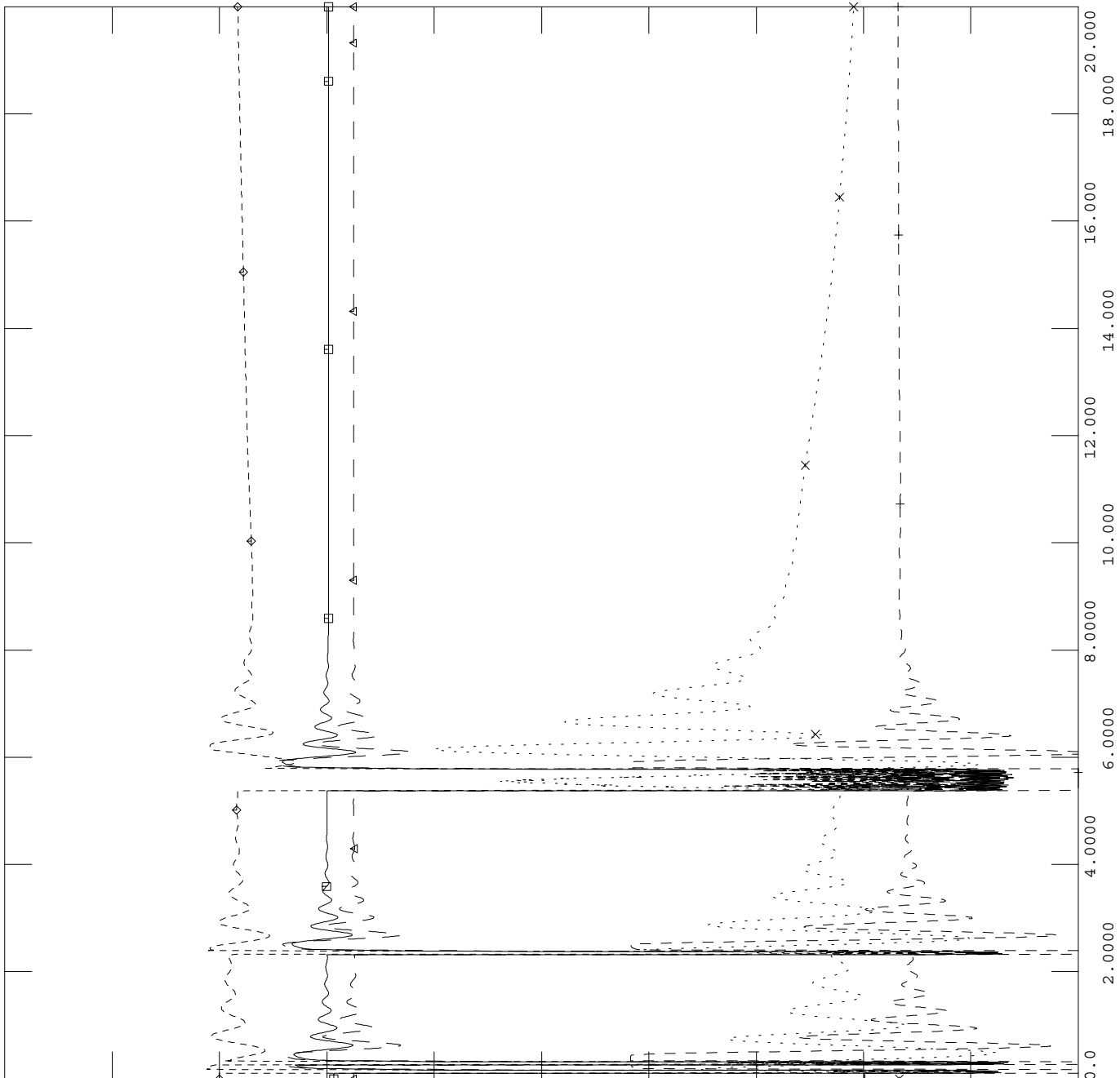

TIME (SECONDS)



SPP MDWG 04 STABILITY;2005 SUMMER PEAK;S05SP-28.CNL;3-12-04
(C) 2004 SOUTHWEST POWER POOL, INC. (SEE DISCLAIMER BELOW)

FILE: FLT33PH.out

0.00150	CHNL# 402: [SPD 55997 [MORLND2 18.000] [1]]	x-----x	-0.0010
0.04000	CHNL# 401: [SPD 56007 [GEN-02-005 34.50] [1]	+-----+	-0.0100
0.02000	CHNL# 400: [SPD 56103 [GEN-03-005 138.00] [2]	◇-----◇	0.01000
0.02000	CHNL# 399: [SPD 56103 [GEN-03-004 138.00] [1]	←-----→	0.01000
0.20150	CHNL# 398: [SPD 55787 [GEN-03-022 0.5750] [1]	□-----□	0.19900

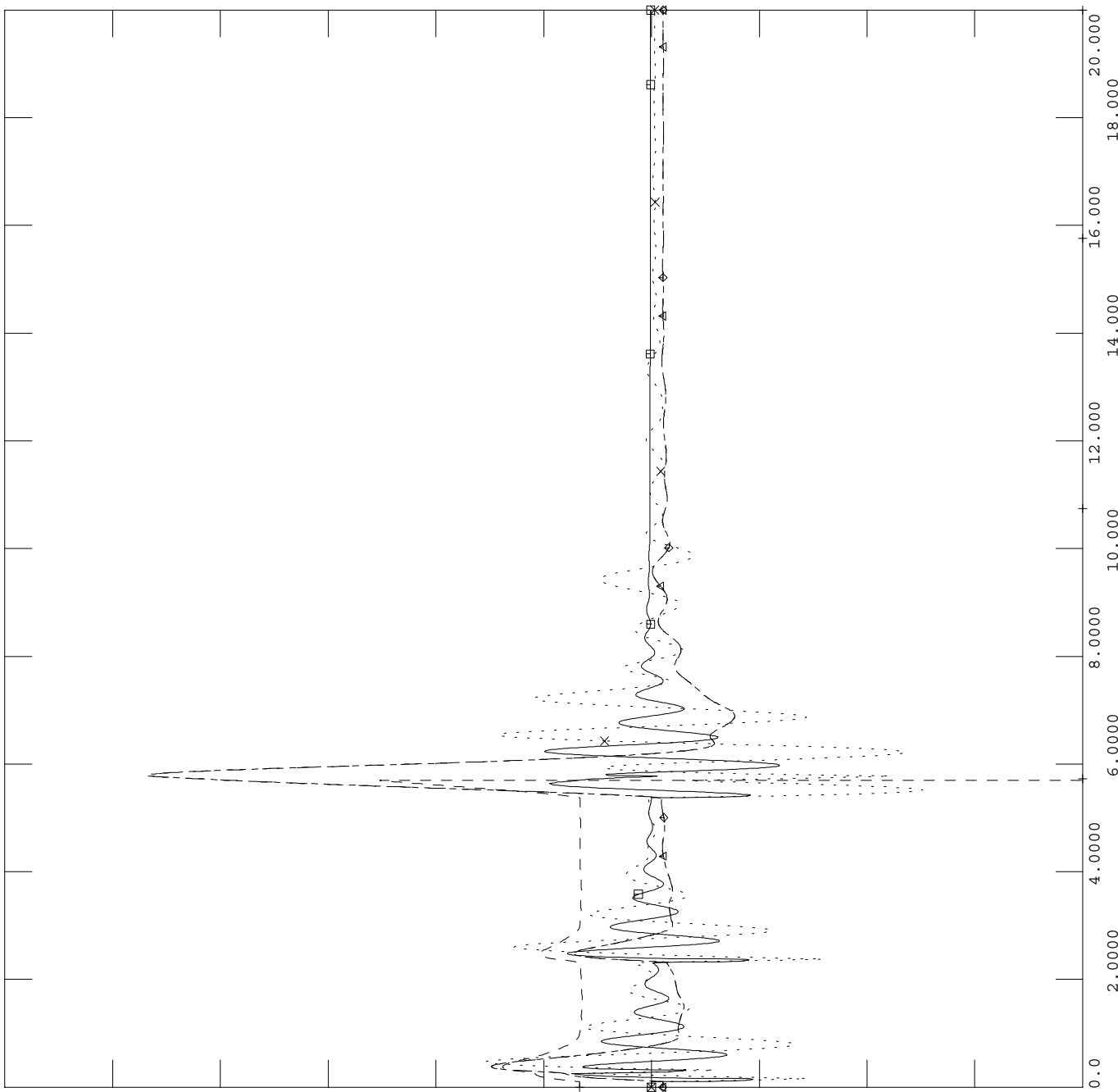

TUE, JUN 08 2004 16:47
OTHER GENERATOR SPEEDS



FILE: FLT41PH.out

TUE, JUN 08 2004 16:47
NEW WIND GENERATOR

0.25000	CHNL# 409: [SPD 90090 [WFD WIND0.5750] [1]]	x-----x	0.19000
1.5000	CHNL# 411: [VARS 90090 [WFD WIND0.5750] [1]]	+-----+	0.0
1.5000	CHNL# 410: [POWR 90090 [WFD WIND0.5750] [1]]	◇-----◇	0.0
1.5000	CHNL# 406: [VOLT 90090 [WFD WIND0.5750]]	←-----→	0.0
1.5000	CHNL# 403: [VOLT 99996 [WFRDT 138.00]]	▣-----▣	0.0

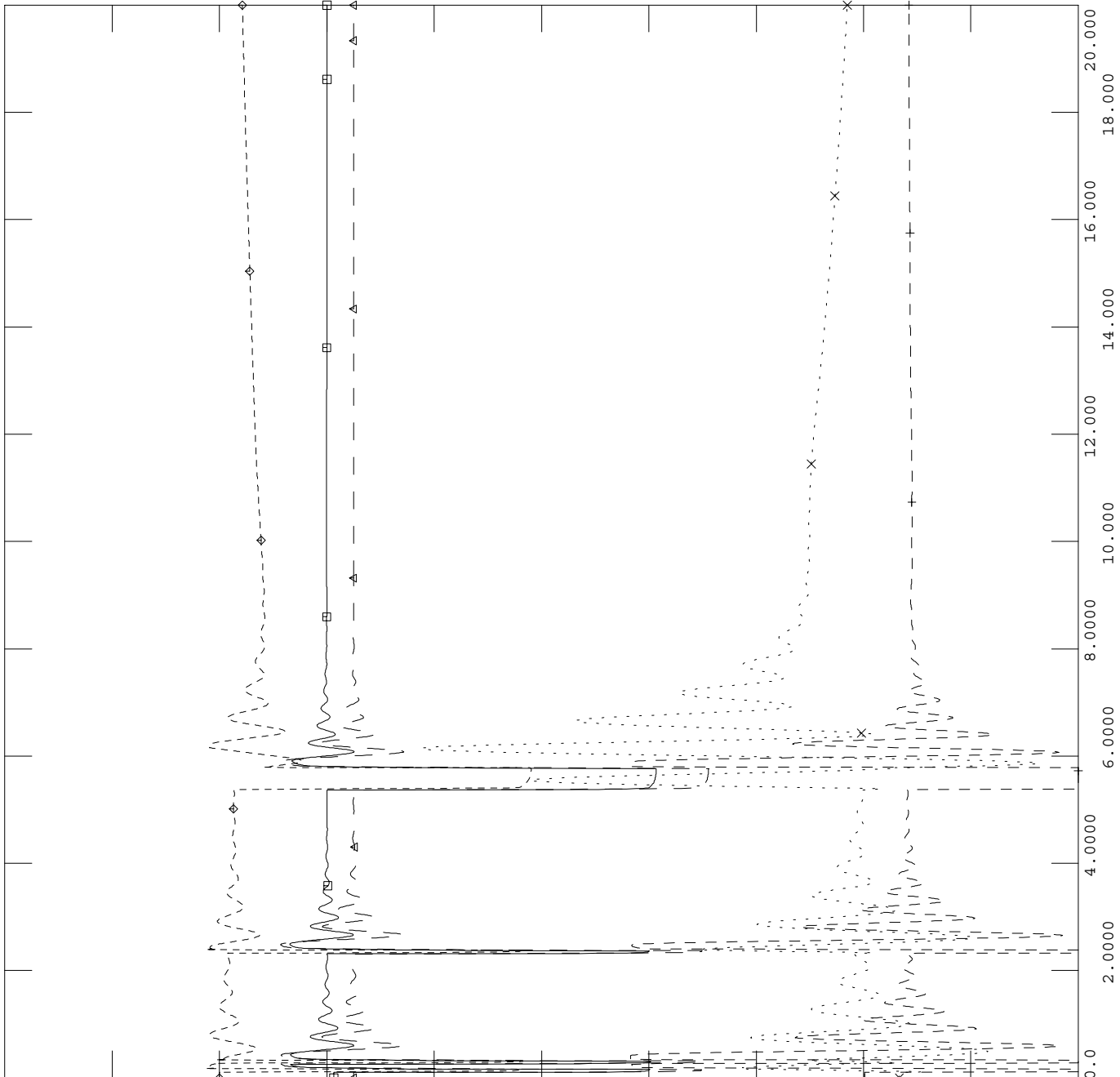

TIME (SECONDS)



SPP MDWG 04 STABILITY;2005 SUMMER PEAK;S05SP-28.CNL;3-12-04
(C) 2004 SOUTHWEST POWER POOL, INC. (SEE DISCLAIMER BELOW)

FILE: FLT41PH.out

0.00150	CHNL# 402: [SPD 55997 [MORLND2 18.000] [1]]	x-----x	-0.0010
0.04000	CHNL# 401: [SPD 56007 [GEN-02-005 34.50] [1]	+-----+	-0.0100
0.02000	CHNL# 400: [SPD 56103 [GEN-03-005 138.00] [2]	◇-----◇	0.01000
0.02000	CHNL# 399: [SPD 56103 [GEN-03-004 138.00] [1]	←-----→	0.01000
0.20150	CHNL# 398: [SPD 55787 [GEN-03-022 0.5750] [1]	□-----□	0.19900

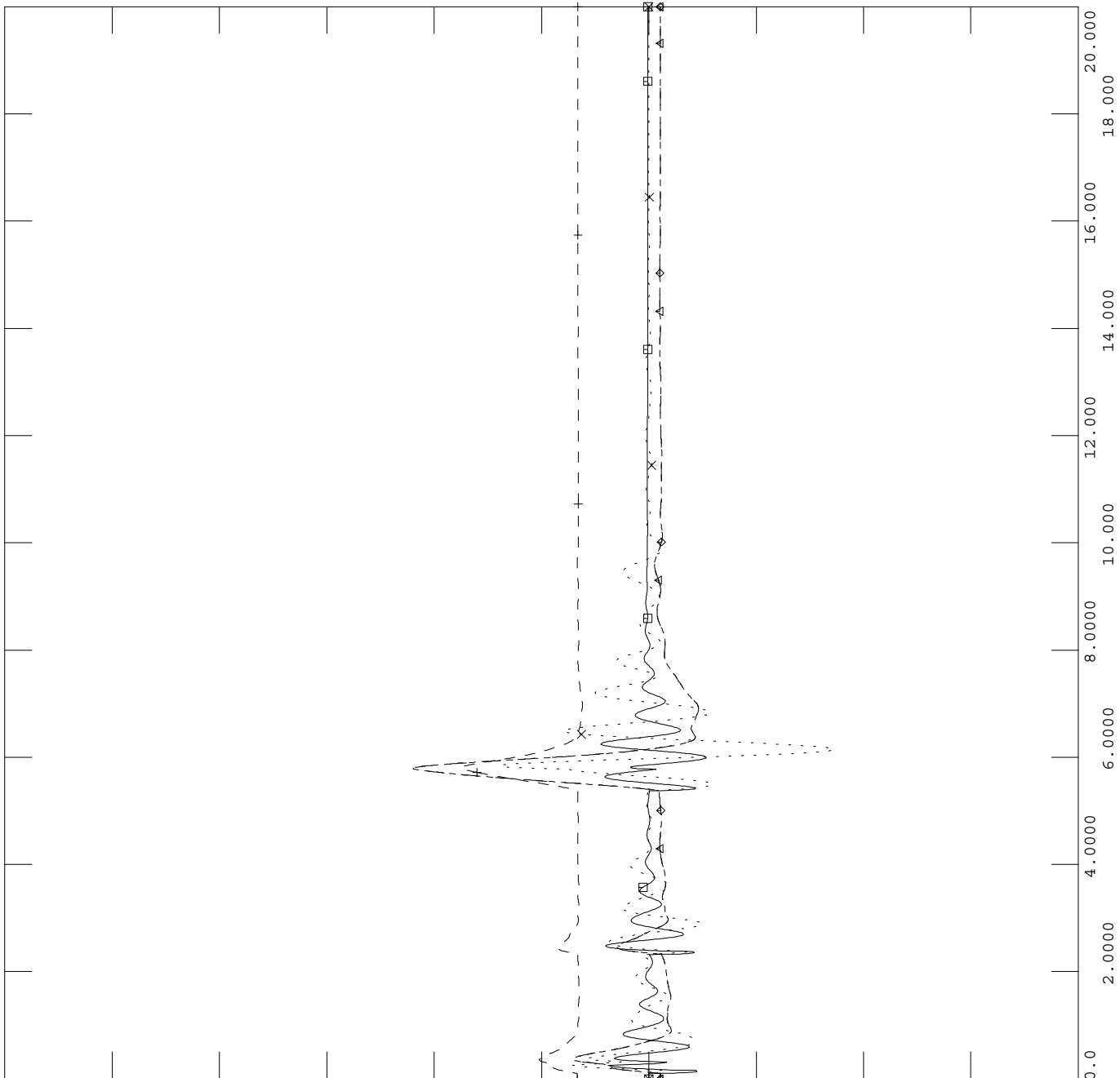

TUE, JUN 08 2004 16:47
OTHER GENERATOR SPEEDS



SPP MDWG 04 STABILITY;2005 SUMMER PEAK;S05SP-28.CNL;3-12-04
(C) 2004 SOUTHWEST POWER POOL, INC. (SEE DISCLAIMER BELOW)

FILE: FLT53PH.out

TUE, JUN 08 2004 16:47
NEW WIND GENERATOR

0.25000	CHNL# 409: [SPD 90090 [WFD WIND0.5750] [1]]	x-----x	0.19000
1.5000	CHNL# 411: [VARS 90090 [WFD WIND0.5750] [1]]	+-----+	0.0
1.5000	CHNL# 410: [POWR 90090 [WFD WIND0.5750] [1]]	◇-----◇	0.0
1.5000	CHNL# 406: [VOLT 90090 [WFD WIND0.5750]]	←-----△	0.0
1.5000	CHNL# 403: [VOLT 99996 [WFRDT 138.00]]	□-----□	0.0

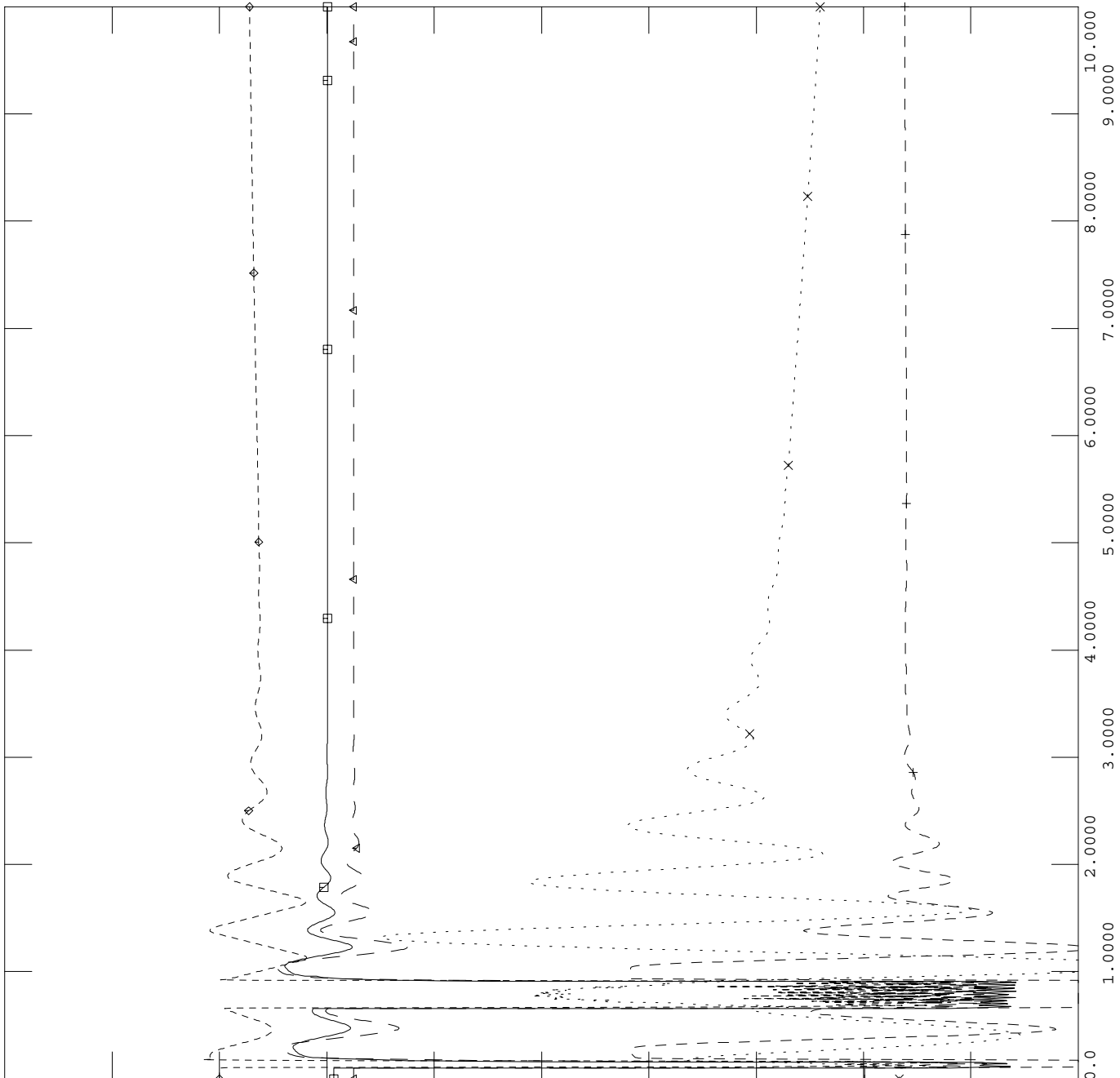

TIME (SECONDS)



SPP MDWG 04 STABILITY;2005 SUMMER PEAK;S05SP-28.CNL;3-12-04
(C) 2004 SOUTHWEST POWER POOL, INC. (SEE DISCLAIMER BELOW)

FILE: FLT53PH.out

TUE, JUN 08 2004 16:47
OTHER GENERATOR SPEEDS

0.00150	CHNL# 402: [SPD 55997 [MORLND2 18.000] [1]]	x-----x	-0.0010
0.04000	CHNL# 401: [SPD 56007 [GEN-02-005 34.50] [1]	+-----+	-0.0100
0.02000	CHNL# 400: [SPD 56103 [GEN-03-005 138.00] [2]	o-----o	0.01000
0.02000	CHNL# 399: [SPD 56103 [GEN-03-004 138.00] [1]	←-----→	0.01000
0.20150	CHNL# 398: [SPD 55787 [GEN-03-022 0.5750] [1]	□-----□	0.19900

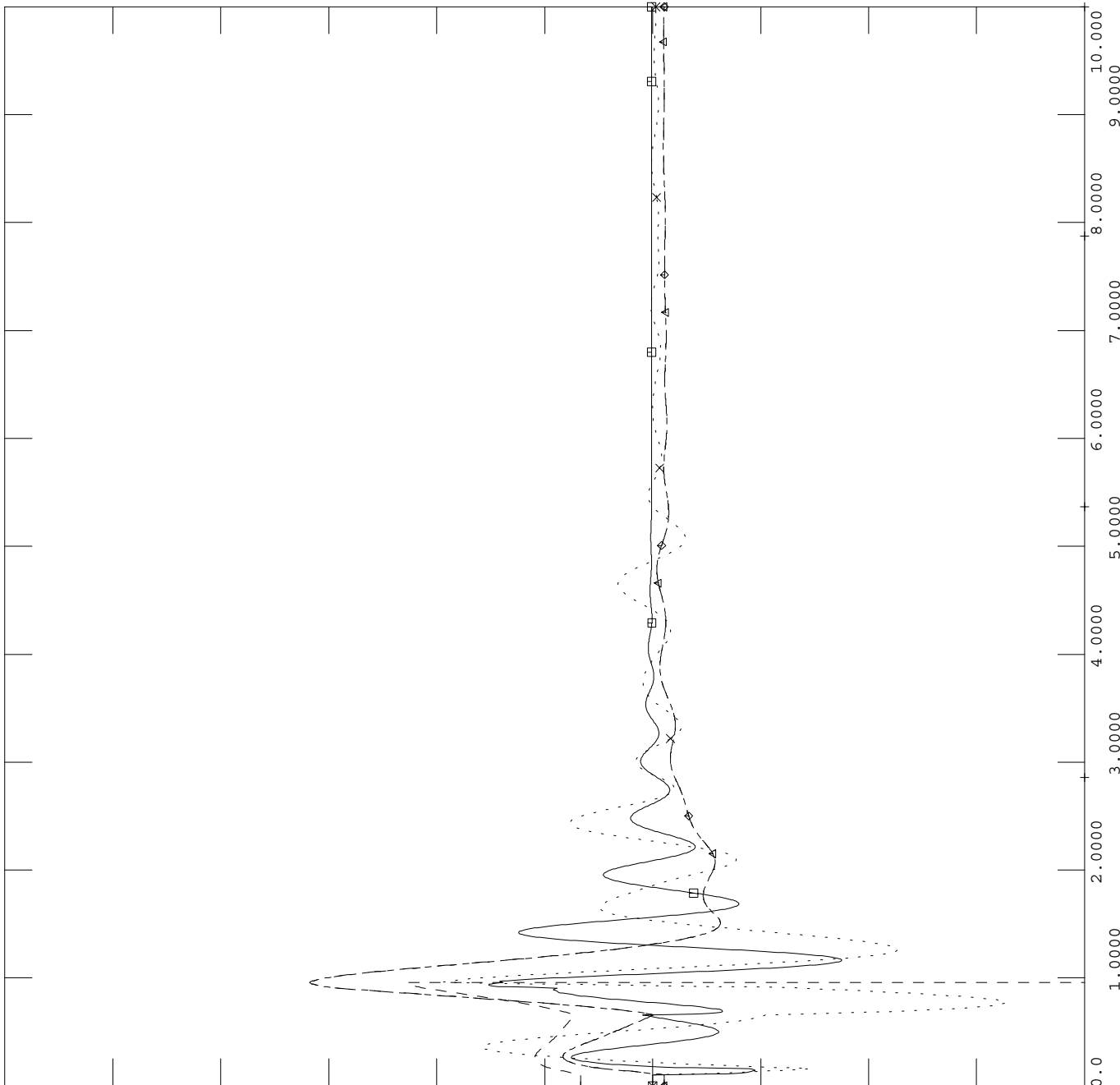



SPP MDWG 04 STABILITY;2005 SUMMER PEAK;S05SP-28.CNL;3-12-04
(C) 2004 SOUTHWEST POWER POOL, INC. (SEE DISCLAIMER BELOW)

FILE: FLT61PH.out

TUE, JUN 08 2004 16:47
NEW WIND GENERATOR

0.25000	CHNL# 409: [SPD 90090 [WFD WIND0.5750] [1]]	x-----x	0.19000
1.5000	CHNL# 411: [VARS 90090 [WFD WIND0.5750] [1]]	+-----+	0.0
1.5000	CHNL# 410: [POWR 90090 [WFD WIND0.5750] [1]]	◇-----◇	0.0
1.5000	CHNL# 406: [VOLT 90090 [WFD WIND0.5750]]	←-----△	0.0
1.5000	CHNL# 403: [VOLT 99996 [WFRDT 138.00]]	□-----□	0.0

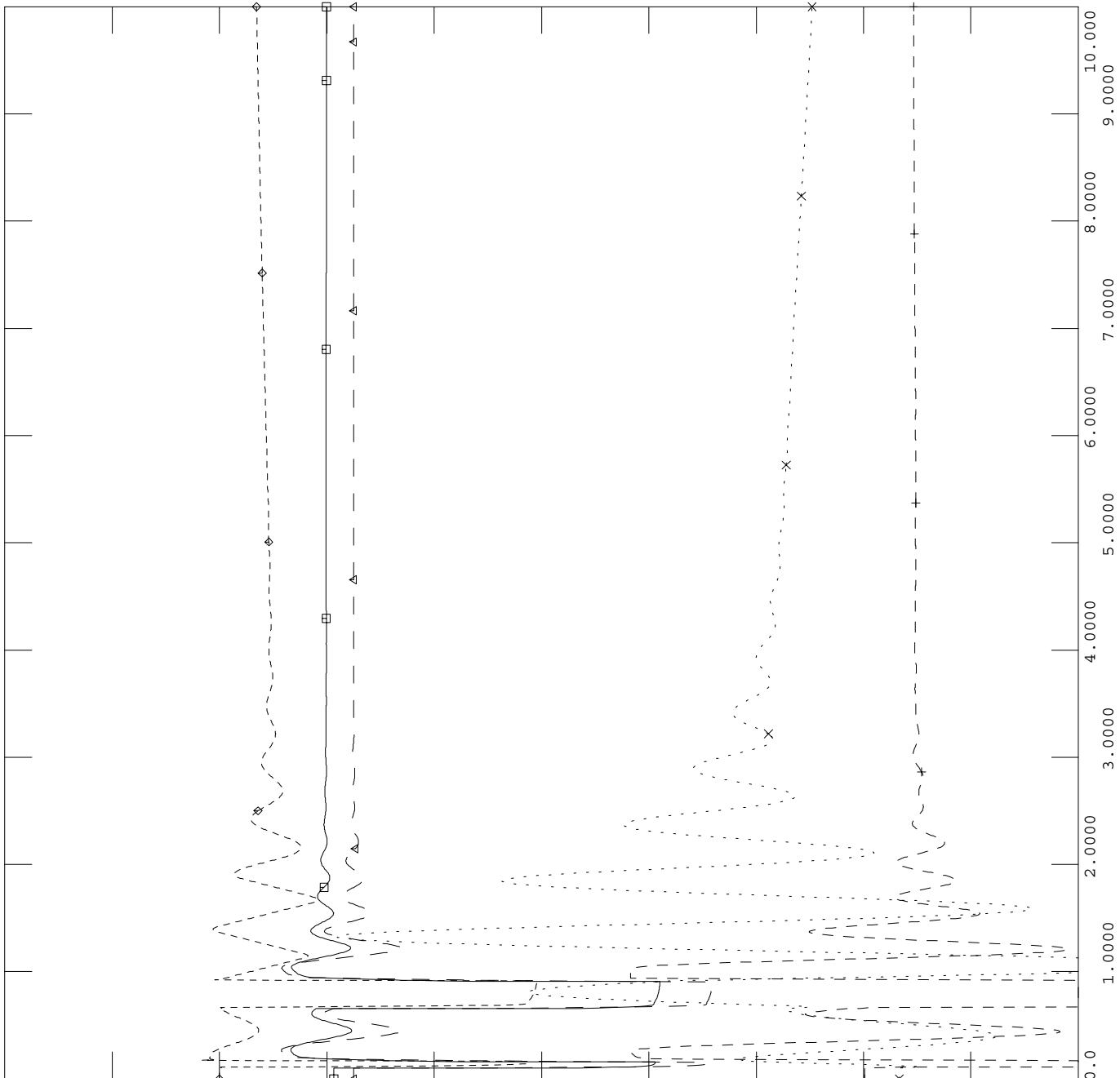

TIME (SECONDS)



SPP MDWG 04 STABILITY;2005 SUMMER PEAK;S05SP-28.CNL;3-12-04
(C) 2004 SOUTHWEST POWER POOL, INC. (SEE DISCLAIMER BELOW)

FILE: FLT61PH.out

0.00150	CHNL# 402: [SPD 55997 [MORLND2 18.000] [1]]	x-----x	-0.0010
0.04000	CHNL# 401: [SPD 56007 [GEN-02-005 34.50] [1]	+-----+	-0.0100
0.02000	CHNL# 400: [SPD 56103 [GEN-03-005 138.00] [2]	◇-----◇	0.01000
0.02000	CHNL# 399: [SPD 56103 [GEN-03-004 138.00] [1]	←-----△	0.01000
0.20150	CHNL# 398: [SPD 55787 [GEN-03-022 0.5750] [1]	□-----□	0.19900

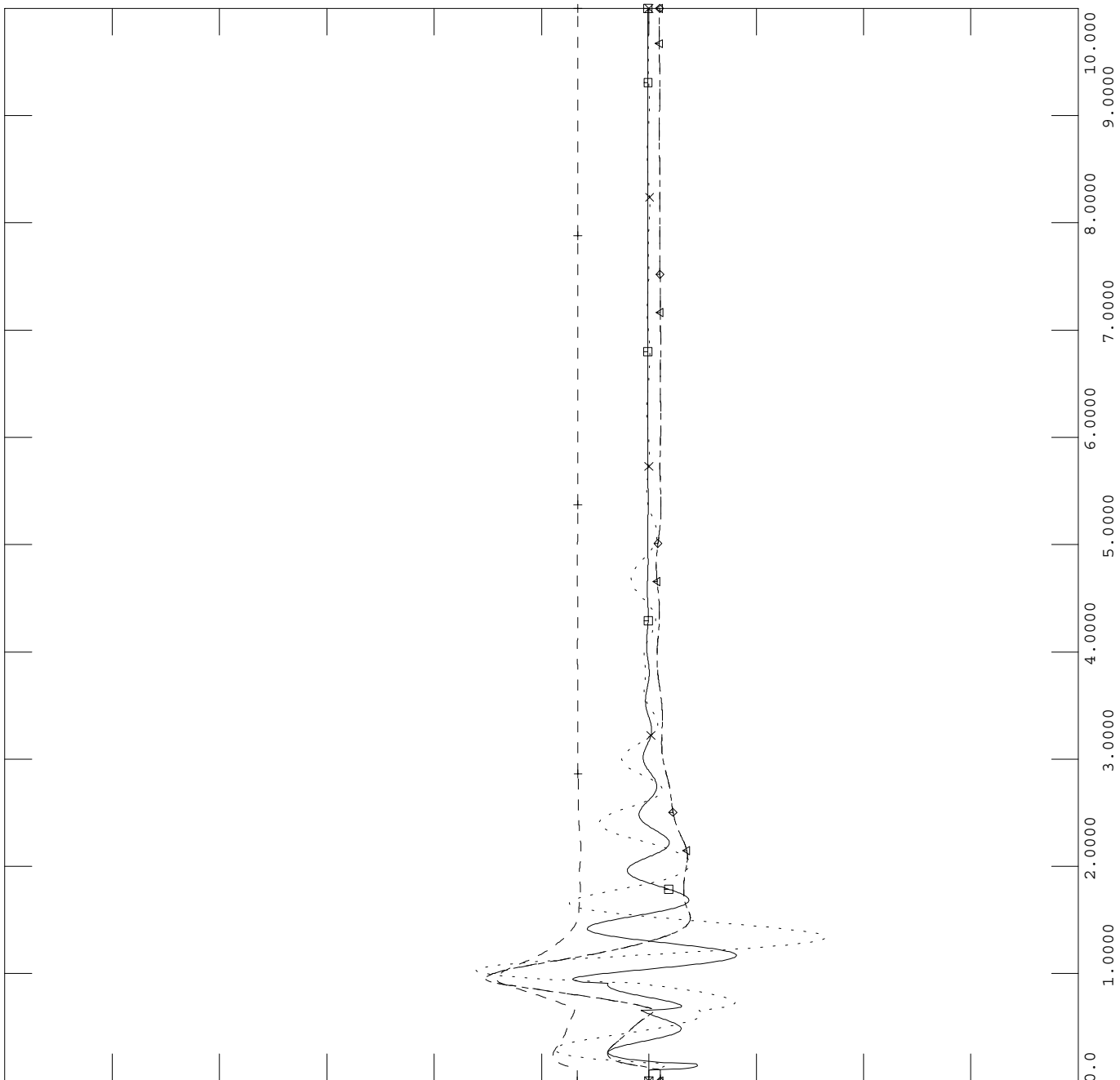

TUE, JUN 08 2004 16:47
OTHER GENERATOR SPEEDS



SPP MDWG 04 STABILITY;2005 SUMMER PEAK;S05SP-28.CNL;3-12-04
(C) 2004 SOUTHWEST POWER POOL, INC. (SEE DISCLAIMER BELOW)

FILE: FLT73PH.out

TUE, JUN 08 2004 16:47
NEW WIND GENERATOR

0.25000	CHNL# 409: [SPD 90090 [WFD WIND0.5750] [1]]	x-----x	0.19000
1.5000	CHNL# 411: [VARS 90090 [WFD WIND0.5750] [1]]	+-----+	0.0
1.5000	CHNL# 410: [POWR 90090 [WFD WIND0.5750] [1]]	o-----o	0.0
1.5000	CHNL# 406: [VOLT 90090 [WFD WIND0.5750]]	^-----^	0.0
1.5000	CHNL# 403: [VOLT 99996 [WFRDT 138.00]]	o-----o	0.0

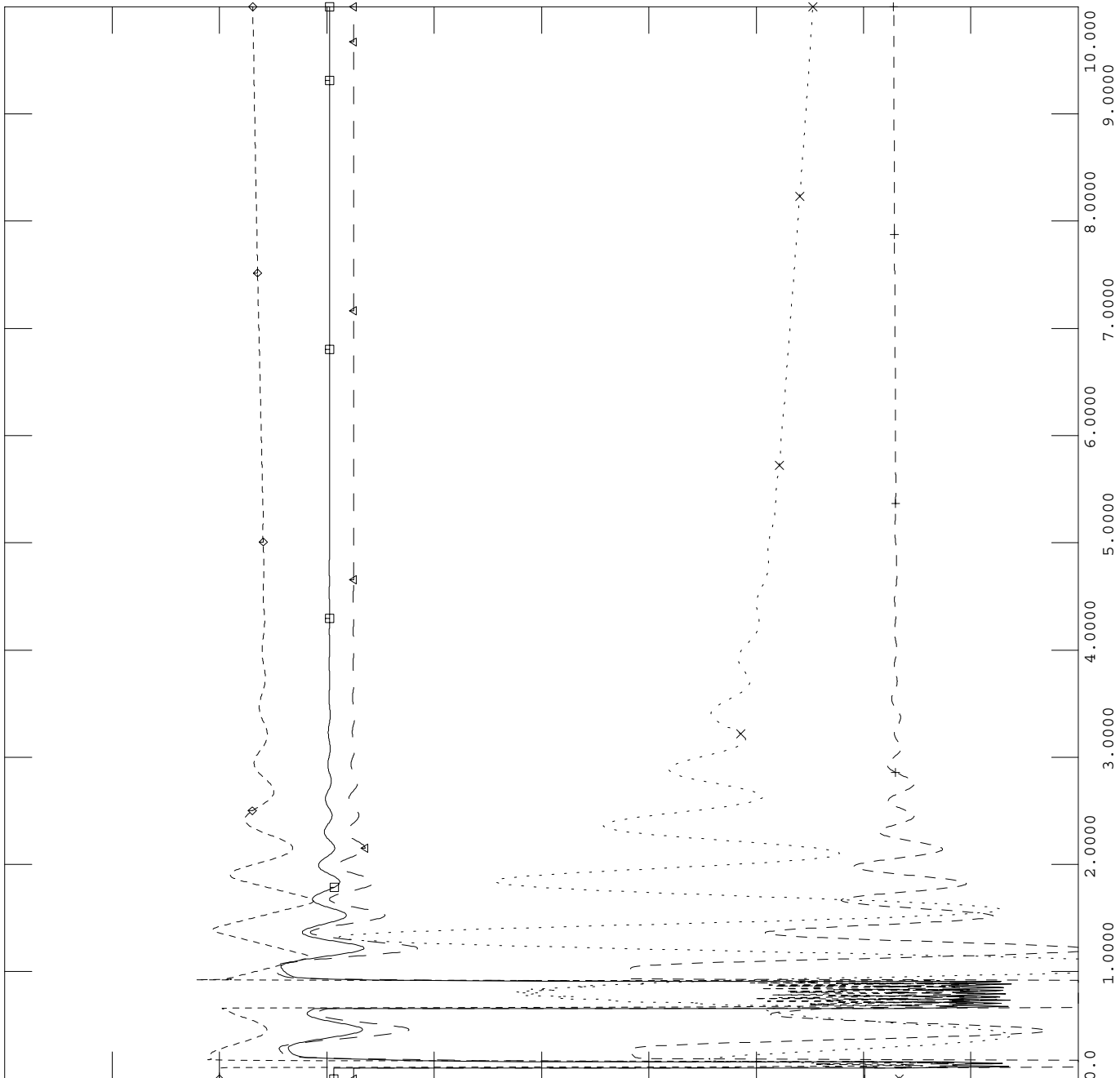



SPP MDWG 04 STABILITY;2005 SUMMER PEAK;S05SP-28.CNL;3-12-04
(C) 2004 SOUTHWEST POWER POOL, INC. (SEE DISCLAIMER BELOW)

FILE: FLT73PH.out

TUE, JUN 08 2004 16:47
OTHER GENERATOR SPEEDS

0.00150	CHNL# 402: [SPD 55997 [MORLND2 18.000] [1]]	x-----x	-0.0010
0.04000	CHNL# 401: [SPD 56007 [GEN-02-005 34.50] [1]	+-----+	-0.0100
0.02000	CHNL# 400: [SPD 56103 [GEN-03-005 138.00] [2]	◇-----◇	0.01000
0.02000	CHNL# 399: [SPD 56103 [GEN-03-004 138.00] [1]	←-----→	0.01000
0.20150	CHNL# 398: [SPD 55787 [GEN-03-022 0.5750] [1]	□-----□	0.19900

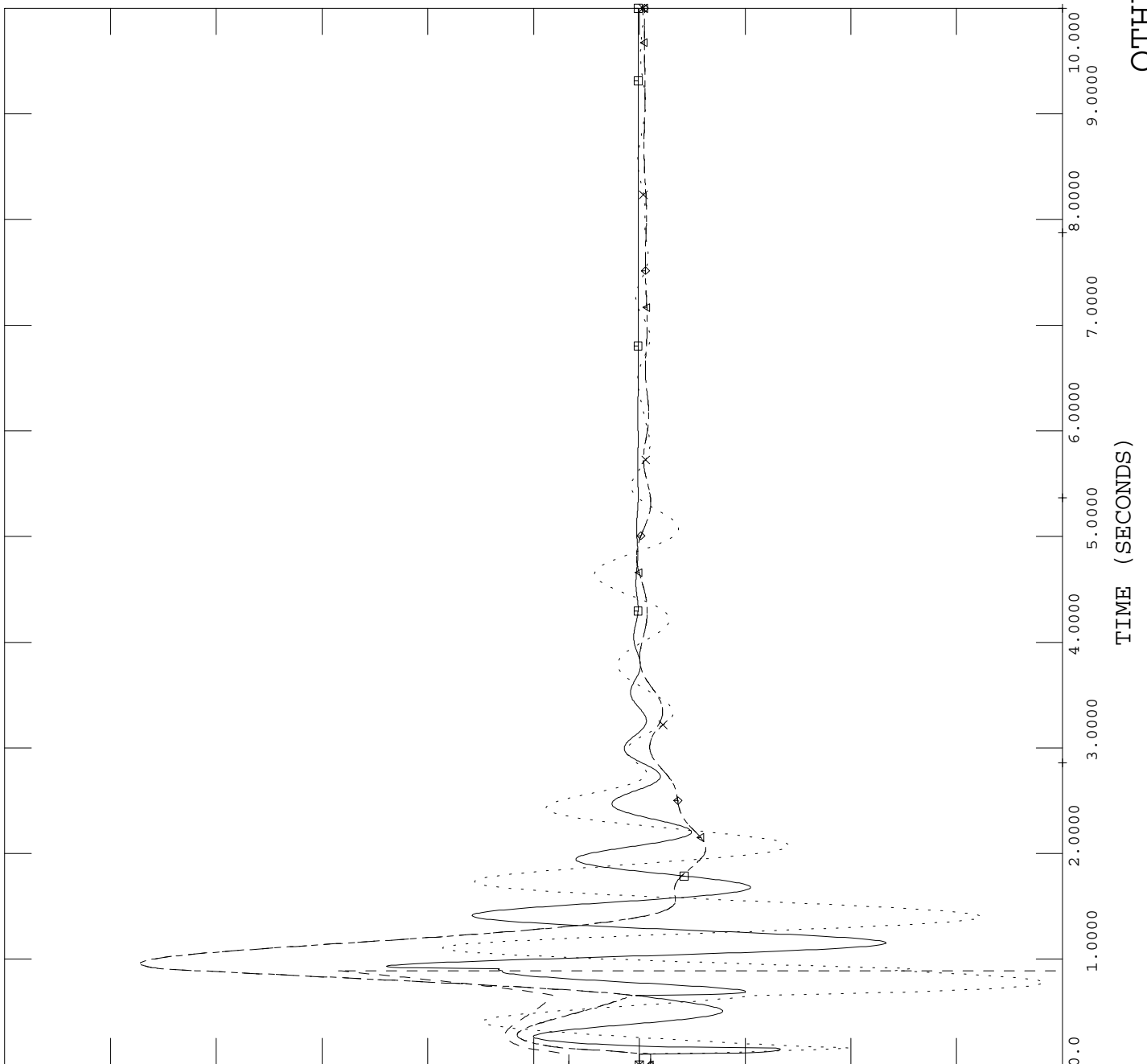



SPP MDWG 04 STABILITY;2005 SUMMER PEAK;S05SP-28.CNL;3-12-04
(C) 2004 SOUTHWEST POWER POOL, INC. (SEE DISCLAIMER BELOW)

FILE: FLT81PH.out

TUE, JUN 08 2004 16:47
NEW WIND GENERATOR

0.25000	CHNL# 409: [SPD 90090 [WFD WIND0.5750] [1]]	x-----x	0.19000
1.5000	CHNL# 411: [VARS 90090 [WFD WIND0.5750] [1]]	+-----+	0.0
1.5000	CHNL# 410: [POWR 90090 [WFD WIND0.5750] [1]]	◇-----◇	0.0
1.5000	CHNL# 406: [VOLT 90090 [WFD WIND0.5750]]	←-----△	0.0
1.5000	CHNL# 403: [VOLT 99996 [WFRDT 138.00]]	□-----□	0.0

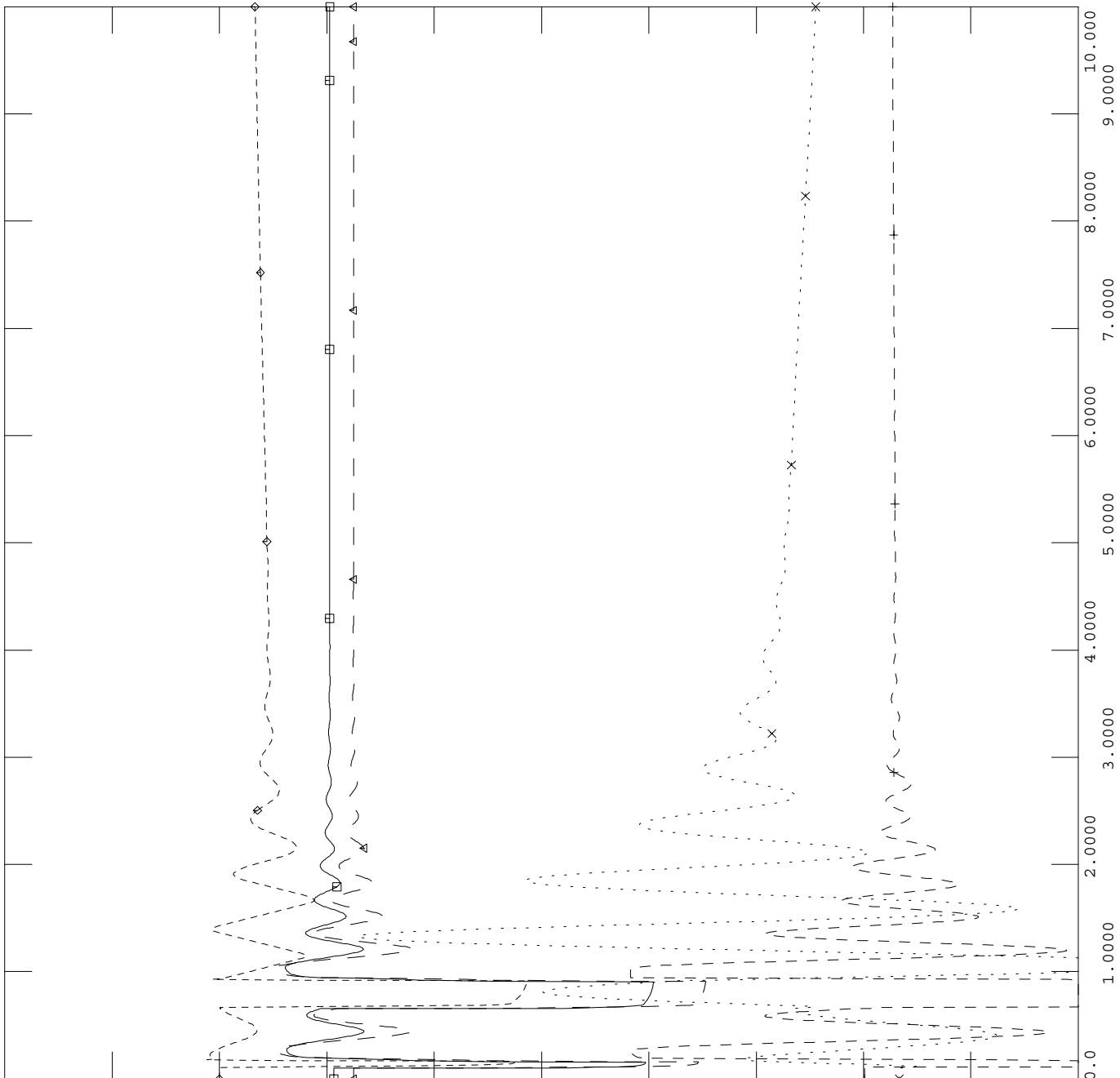



SPP MDWG 04 STABILITY;2005 SUMMER PEAK;S05SP-28.CNL;3-12-04
(C) 2004 SOUTHWEST POWER POOL, INC. (SEE DISCLAIMER BELOW)

FILE: FLT81PH.out

TUE, JUN 08 2004 16:47
OTHER GENERATOR SPEEDS

0.00150	CHNL# 402: [SPD 55997 [MORLND2 18.000] [1]]	x-----x	-0.0010
0.04000	CHNL# 401: [SPD 56007 [GEN-02-005 34.50] [1]	+-----+	-0.0100
0.02000	CHNL# 400: [SPD 56103 [GEN-03-005 138.00] [2]	◇-----◇	0.01000
0.02000	CHNL# 399: [SPD 56103 [GEN-03-004 138.00] [1]	←-----△	0.01000
0.20150	CHNL# 398: [SPD 55787 [GEN-03-022 0.5750] [1]	□-----□	0.19900

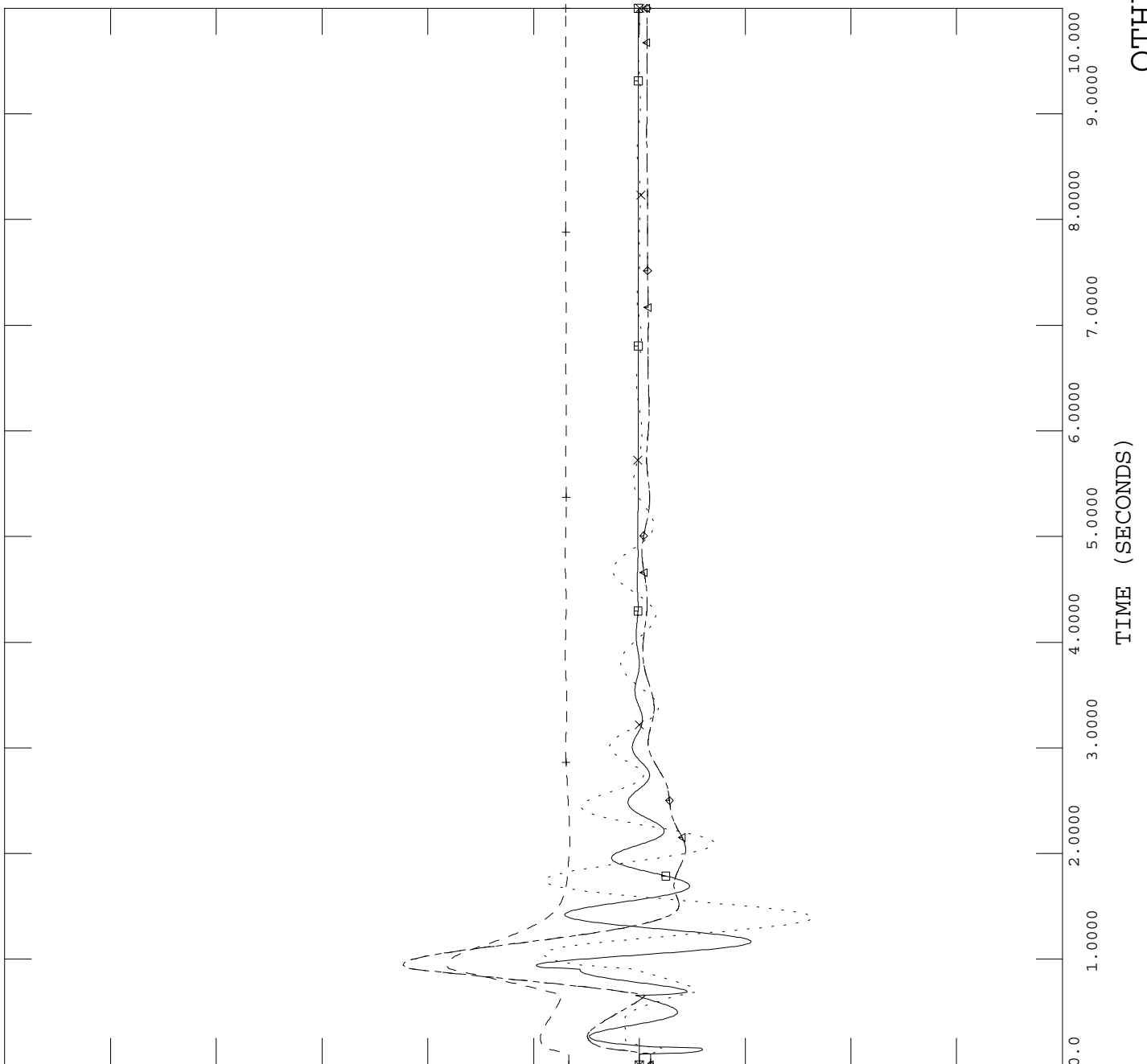



SPP MDWG 04 STABILITY;2005 SUMMER PEAK;S05SP-28.CNL;3-12-04
(C) 2004 SOUTHWEST POWER POOL, INC. (SEE DISCLAIMER BELOW)

FILE: FLT93PH.out

0.25000	CHNL# 409: [SPD 90090 [WFD WIND0.5750] [1]]	x-----x	0.19000
1.5000	CHNL# 411: [VARS 90090 [WFD WIND0.5750] [1]]	+-----+	0.0
1.5000	CHNL# 410: [POWR 90090 [WFD WIND0.5750] [1]]	◇-----◇	0.0
1.5000	CHNL# 406: [VOLT 90090 [WFD WIND0.5750]]	←-----→	0.0
1.5000	CHNL# 403: [VOLT 99996 [WFRDT 138.00]]	▣-----▣	0.0

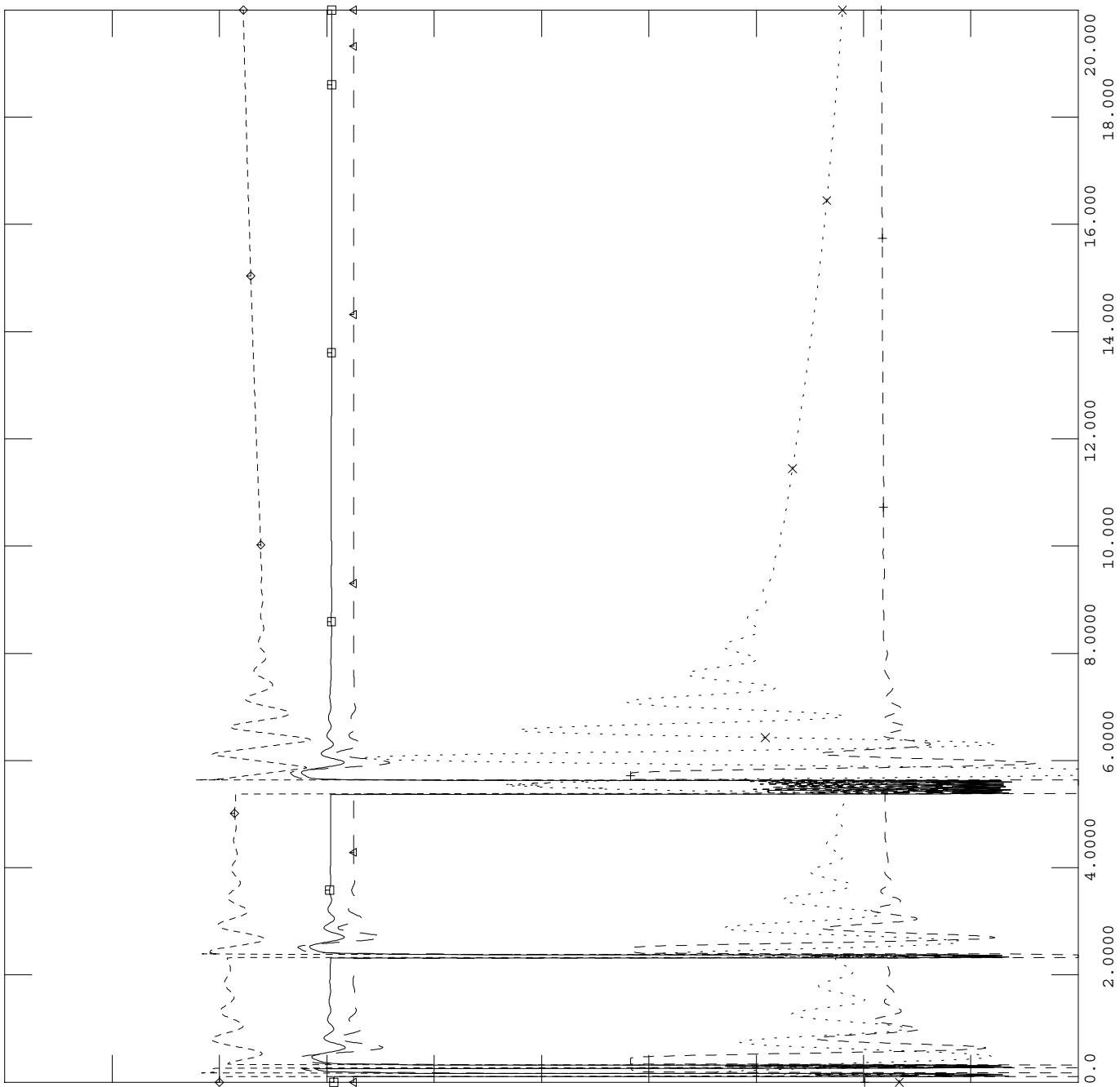

TUE, JUN 08 2004 16:47
NEW WIND GENERATOR

TIME (SECONDS)



SPP MDWG 04 STABILITY;2005 SUMMER PEAK;S05SP-28.CNL;3-12-04
(C) 2004 SOUTHWEST POWER POOL, INC. (SEE DISCLAIMER BELOW)

FILE: FLT93PH.out

0.00150	CHNL# 402: [SPD 55997 [MORLND2 18.000] [1]]	x-----x	-0.0010
0.04000	CHNL# 401: [SPD 56007 [GEN-02-005 34.50] [1]	+-----+	-0.0100
0.02000	CHNL# 400: [SPD 56103 [GEN-03-005 138.00] [2]	◇-----◇	0.01000
0.02000	CHNL# 399: [SPD 56103 [GEN-03-004 138.00] [1]	←-----→	0.01000
0.20150	CHNL# 398: [SPD 55787 [GEN-03-022 0.5750] [1]	□-----□	0.19900

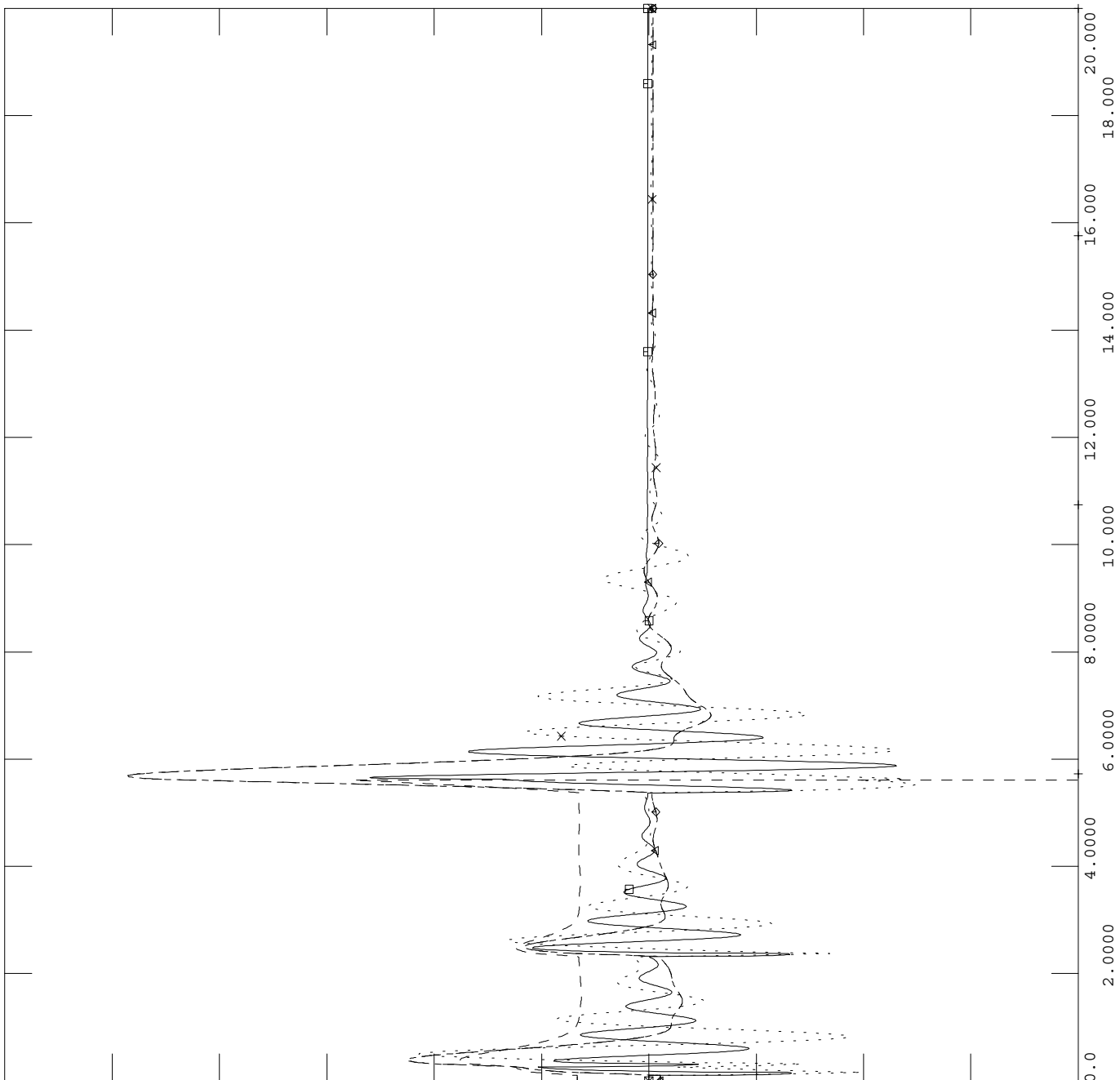

TUE, JUN 08 2004 16:47
OTHER GENERATOR SPEEDS



SPP MDWG 04 STABILITY;2005 SUMMER PEAK;S05SP-28.CNL;3-12-04
(C) 2004 SOUTHWEST POWER POOL, INC. (SEE DISCLAIMER BELOW)

FILE: FLT101PH.out

TUE, JUN 08 2004 16:47
NEW WIND GENERATOR

0.25000	CHNL# 409: [SPD 90090 [WFD WIND0.5750] [1]]	x-----x	0.19000
1.5000	CHNL# 411: [VARS 90090 [WFD WIND0.5750] [1]]	+-----+	0.0
1.5000	CHNL# 410: [POWR 90090 [WFD WIND0.5750] [1]]	◇-----◇	0.0
1.5000	CHNL# 406: [VOLT 90090 [WFD WIND0.5750]]	←-----→	0.0
1.5000	CHNL# 403: [VOLT 99996 [WFRDT 138.00]]	▣-----▣	0.0

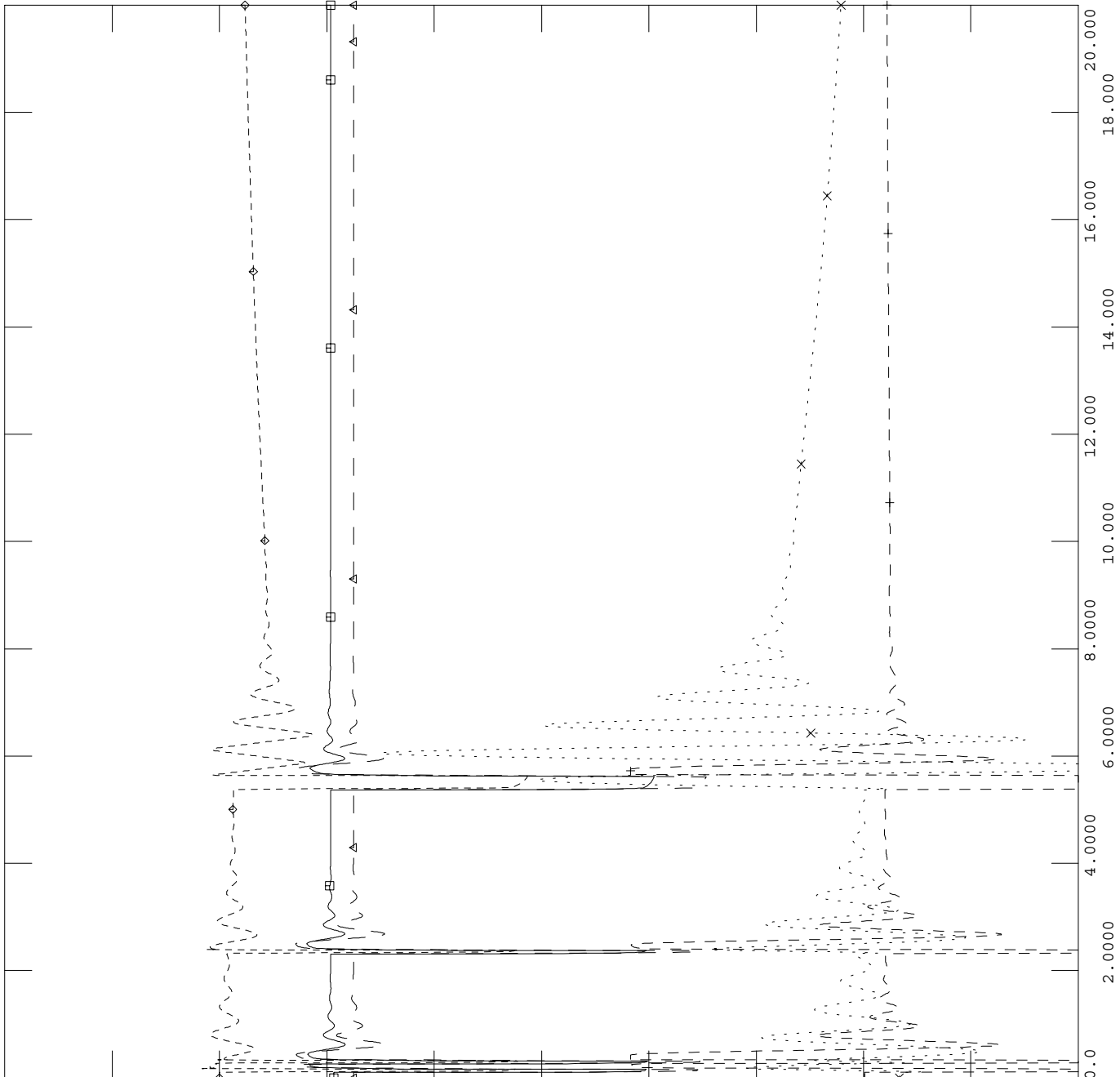

TIME (SECONDS)



SPP MDWG 04 STABILITY;2005 SUMMER PEAK;S05SP-28.CNL;3-12-04
(C) 2004 SOUTHWEST POWER POOL, INC. (SEE DISCLAIMER BELOW)

FILE: FLT101PH.out

0.00150	CHNL# 402: [SPD 55997 [MORLND2 18.000] [1]]	x-----x	-0.0010
0.04000	CHNL# 401: [SPD 56007 [GEN-02-005 34.50] [1]	+-----+	-0.0100
0.02000	CHNL# 400: [SPD 56103 [GEN-03-005 138.00] [2]	◇-----◇	0.01000
0.02000	CHNL# 399: [SPD 56103 [GEN-03-004 138.00] [1]	←-----→	0.01000
0.20150	CHNL# 398: [SPD 55787 [GEN-03-022 0.5750] [1]	□-----□	0.19900

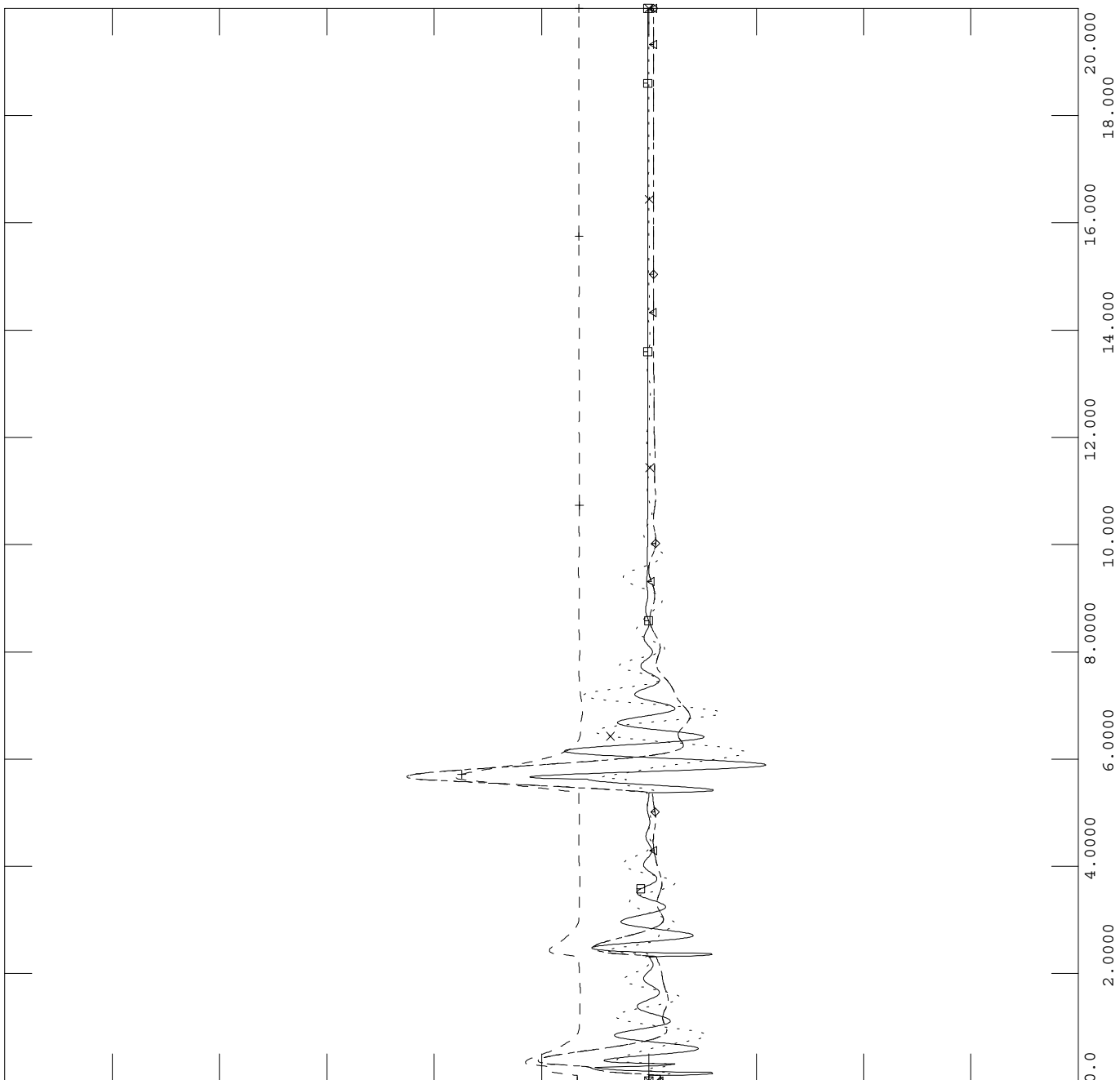

TUE, JUN 08 2004 16:47
OTHER GENERATOR SPEEDS



SPP MDWG 04 STABILITY;2005 SUMMER PEAK;S05SP-28.CNL;3-12-04
(C) 2004 SOUTHWEST POWER POOL, INC. (SEE DISCLAIMER BELOW)

FILE: FLT113PH.out

TUE, JUN 08 2004 16:47
NEW WIND GENERATOR

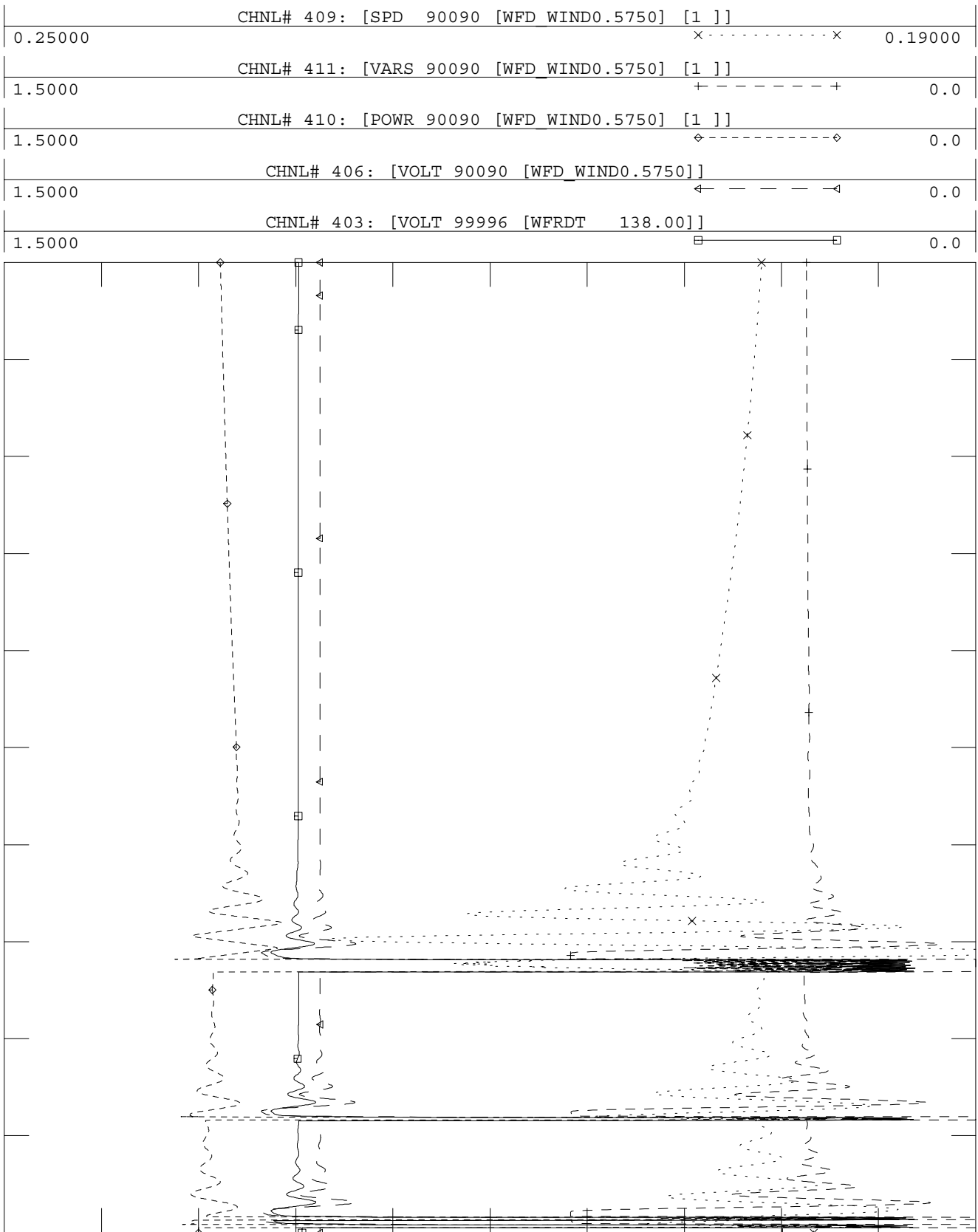



SPP MDWG 04 STABILITY;2005 SUMMER PEAK;S05SP-28.CNL;3-12-04
(C) 2004 SOUTHWEST POWER POOL, INC. (SEE DISCLAIMER BELOW)

FILE: FLT113PH.out

0.00150	CHNL# 402: [SPD 55997 [MORLND2 18.000] [1]]	x-----x	-0.0010
0.04000	CHNL# 401: [SPD 56007 [GEN-02-005 34.50] [1]	+-----+	-0.0100
0.02000	CHNL# 400: [SPD 56103 [GEN-03-005 138.00] [2]	◇-----◇	0.01000
0.02000	CHNL# 399: [SPD 56103 [GEN-03-004 138.00] [1]	←-----→	0.01000
0.20150	CHNL# 398: [SPD 55787 [GEN-03-022 0.5750] [1]	□-----□	0.19900

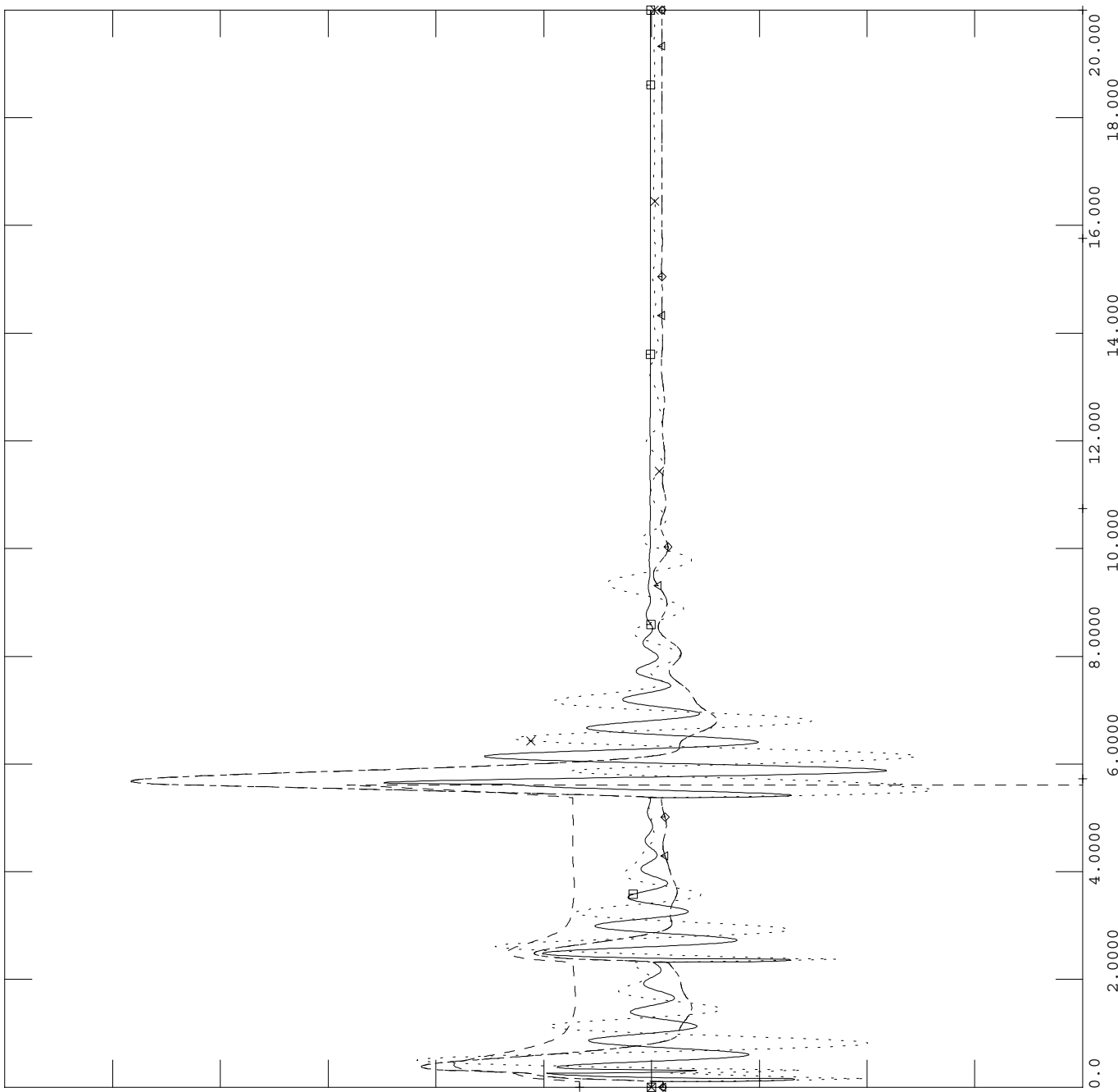

TUE, JUN 08 2004 16:47
OTHER GENERATOR SPEEDS



SPP MDWG 04 STABILITY;2005 SUMMER PEAK;S05SP-28.CNL;3-12-04
(C) 2004 SOUTHWEST POWER POOL, INC. (SEE DISCLAIMER BELOW)

FILE: FLT121PH.out

0.25000	CHNL# 409: [SPD 90090 [WFD WIND0.5750] [1]]	x-----x	0.19000
1.5000	CHNL# 411: [VARS 90090 [WFD WIND0.5750] [1]]	+-----+	0.0
1.5000	CHNL# 410: [POWR 90090 [WFD WIND0.5750] [1]]	◇-----◇	0.0
1.5000	CHNL# 406: [VOLT 90090 [WFD WIND0.5750]]	←-----→	0.0
1.5000	CHNL# 403: [VOLT 99996 [WFRDT 138.00]]	▣-----▣	0.0

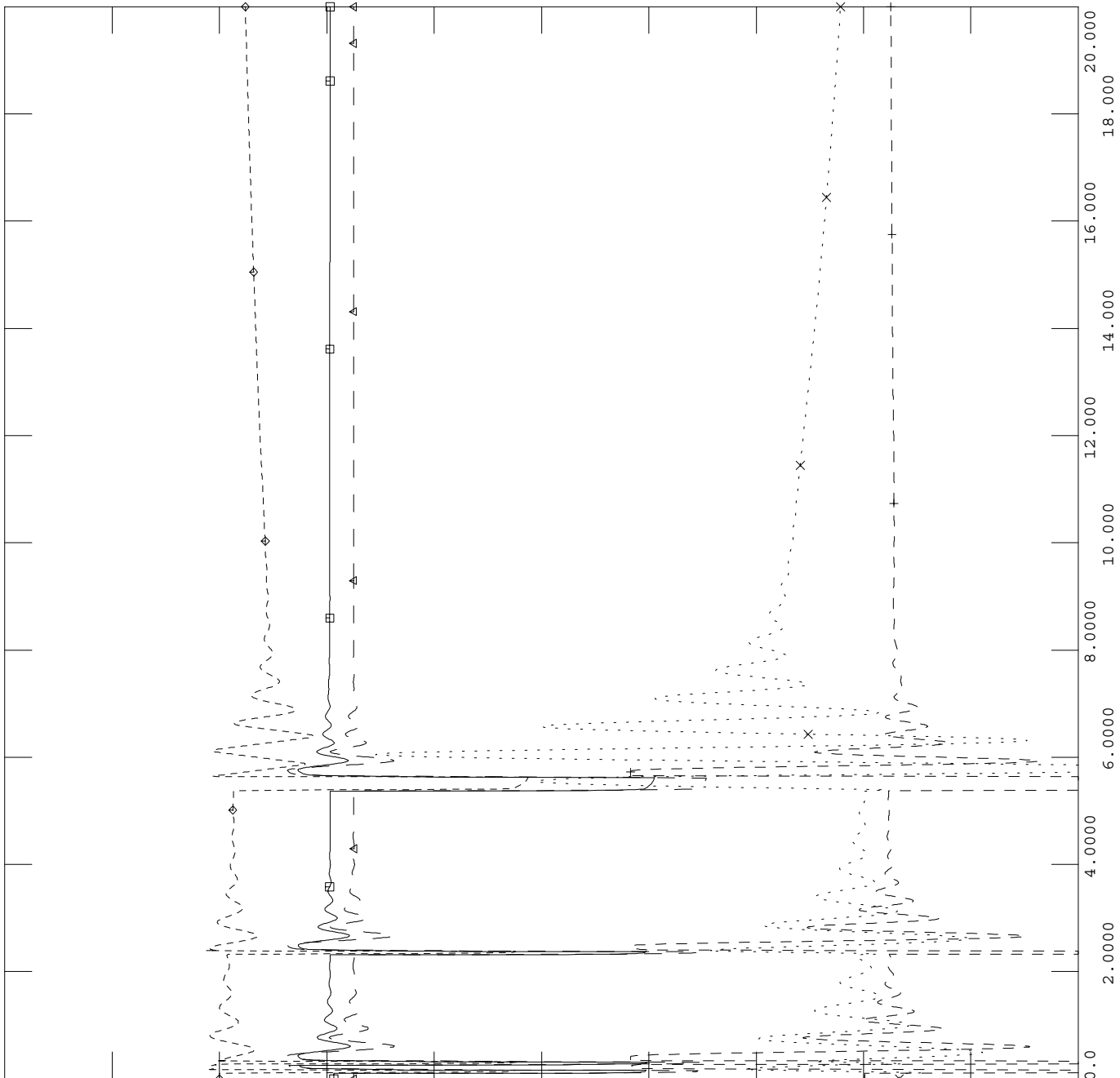

TUE, JUN 08 2004 16:47
NEW WIND GENERATOR

TIME (SECONDS)



SPP MDWG 04 STABILITY;2005 SUMMER PEAK;S05SP-28.CNL;3-12-04
(C) 2004 SOUTHWEST POWER POOL, INC. (SEE DISCLAIMER BELOW)

FILE: FLT121PH.out

0.00150	CHNL# 402: [SPD 55997 [MORLND2 18.000] [1]]	x-----x	-0.0010
0.04000	CHNL# 401: [SPD 56007 [GEN-02-005 34.50] [1]	+-----+	-0.0100
0.02000	CHNL# 400: [SPD 56103 [GEN-03-005 138.00] [2]	◇-----◇	0.01000
0.02000	CHNL# 399: [SPD 56103 [GEN-03-004 138.00] [1]	←-----△	0.01000
0.20150	CHNL# 398: [SPD 55787 [GEN-03-022 0.5750] [1]	□-----□	0.19900

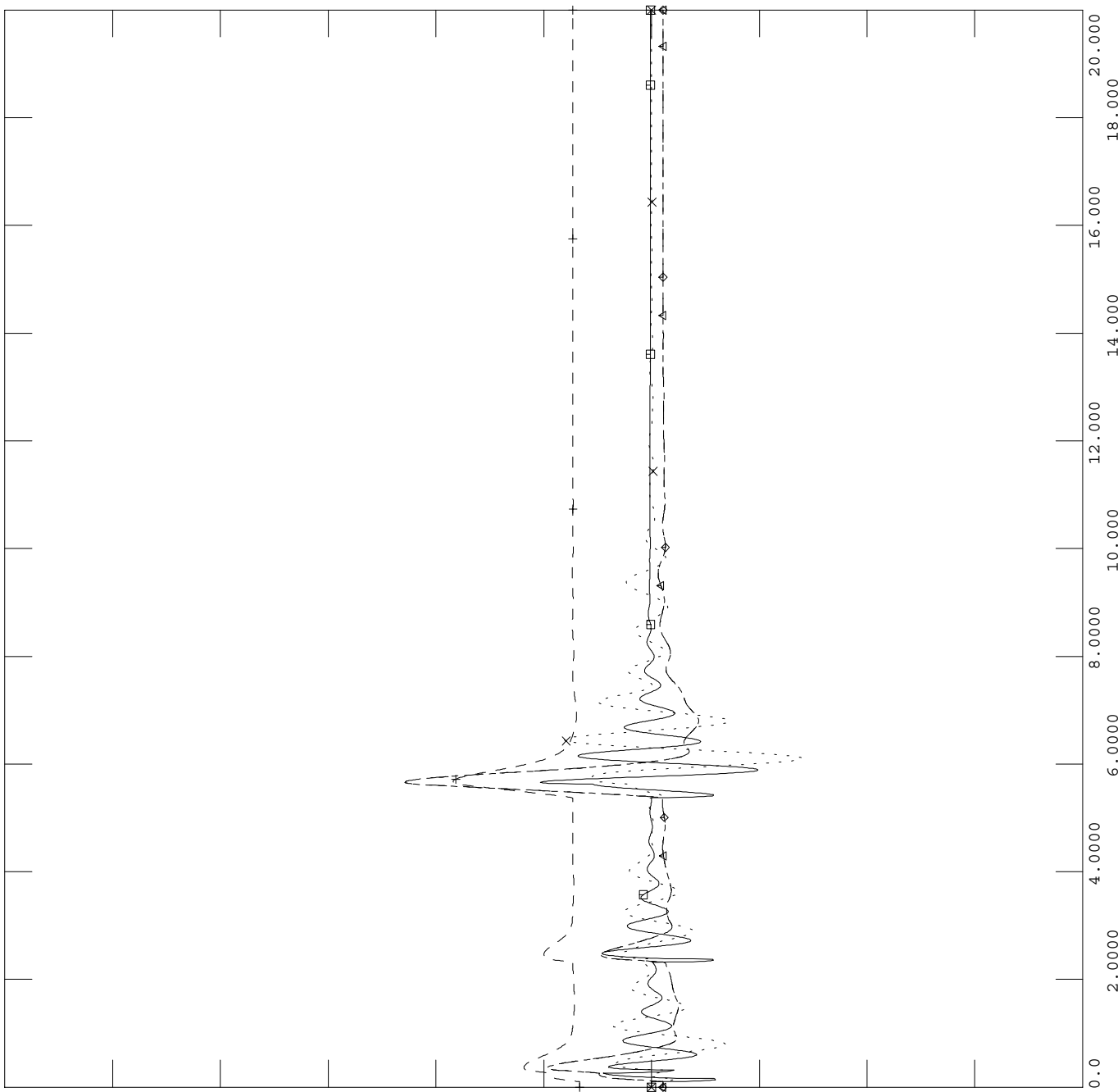

TUE, JUN 08 2004 16:47
OTHER GENERATOR SPEEDS



SPP MDWG 04 STABILITY;2005 SUMMER PEAK;S05SP-28.CNL;3-12-04
(C) 2004 SOUTHWEST POWER POOL, INC. (SEE DISCLAIMER BELOW)

FILE: FLT133PH.out

TUE, JUN 08 2004 16:47
NEW WIND GENERATOR

0.35000	CHNL# 409: [SPD 90090 [WFD WIND0.5750] [1]]	x-----x	0.19000
1.5000	CHNL# 411: [VARS 90090 [WFD WIND0.5750] [1]]	+-----+	0.0
1.5000	CHNL# 410: [POWR 90090 [WFD WIND0.5750] [1]]	◇-----◇	0.0
1.5000	CHNL# 406: [VOLT 90090 [WFD WIND0.5750]]	←-----△	0.0
1.5000	CHNL# 403: [VOLT 99996 [WFRDT 138.00]]	□-----□	0.0

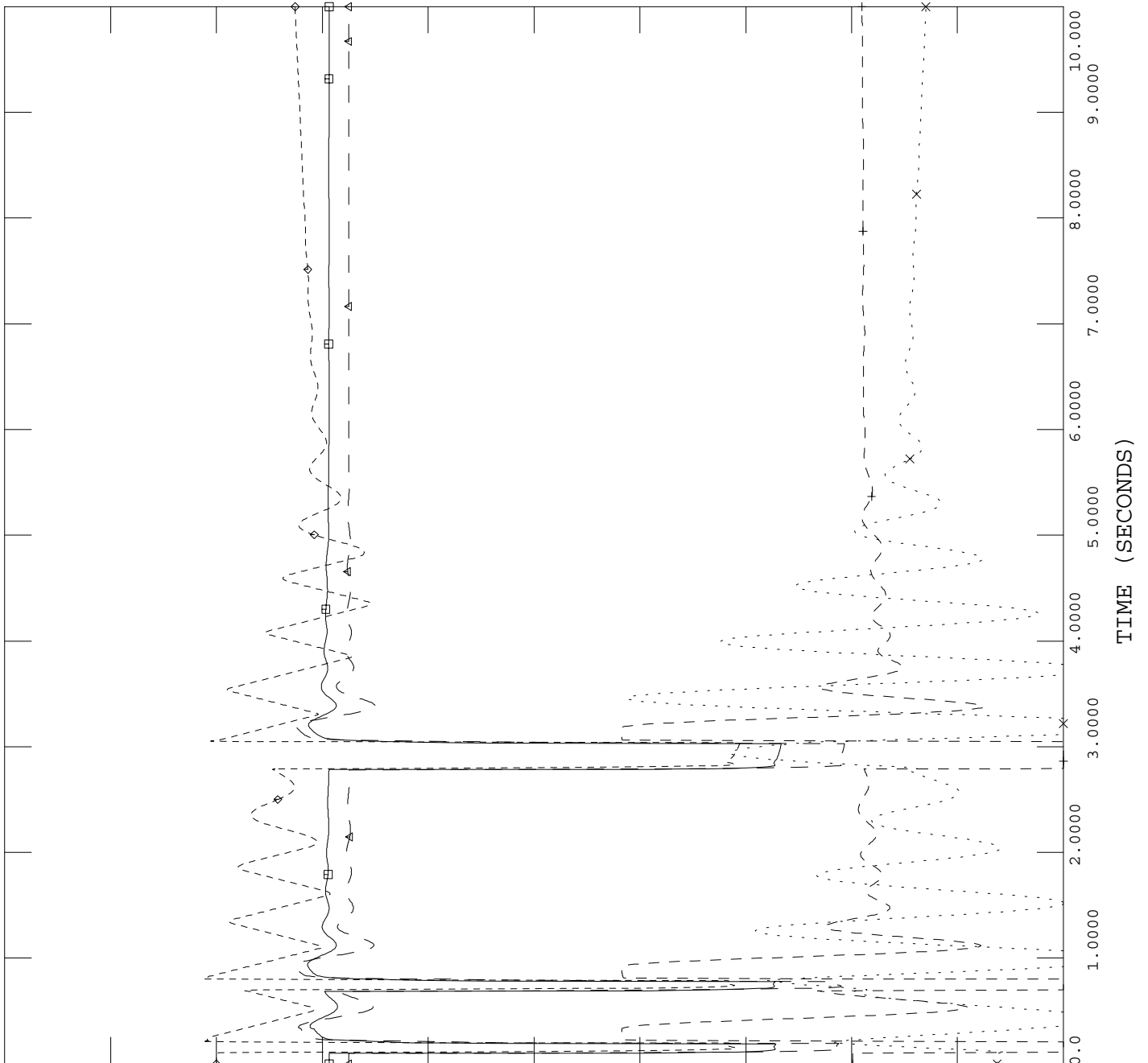



SPP MDWG 04 STABILITY;2005 SUMMER PEAK;S05SP-28.CNL;3-12-04
(C) 2004 SOUTHWEST POWER POOL, INC. (SEE DISCLAIMER BELOW)

FILE: FLT133PH.out

0.00150	CHNL# 402: [SPD 55997 [MORLND2 18.000] [1]]	x-----x	-0.0010
0.04000	CHNL# 401: [SPD 56007 [GEN-02-005 34.50] [1]	+-----+	-0.0100
0.02000	CHNL# 400: [SPD 56103 [GEN-03-005 138.00] [2]	◇-----◇	0.01000
0.02000	CHNL# 399: [SPD 56103 [GEN-03-004 138.00] [1]	←-----→	0.01000
0.21500	CHNL# 398: [SPD 55787 [GEN-03-022 0.5750] [1]	□-----□	0.19000

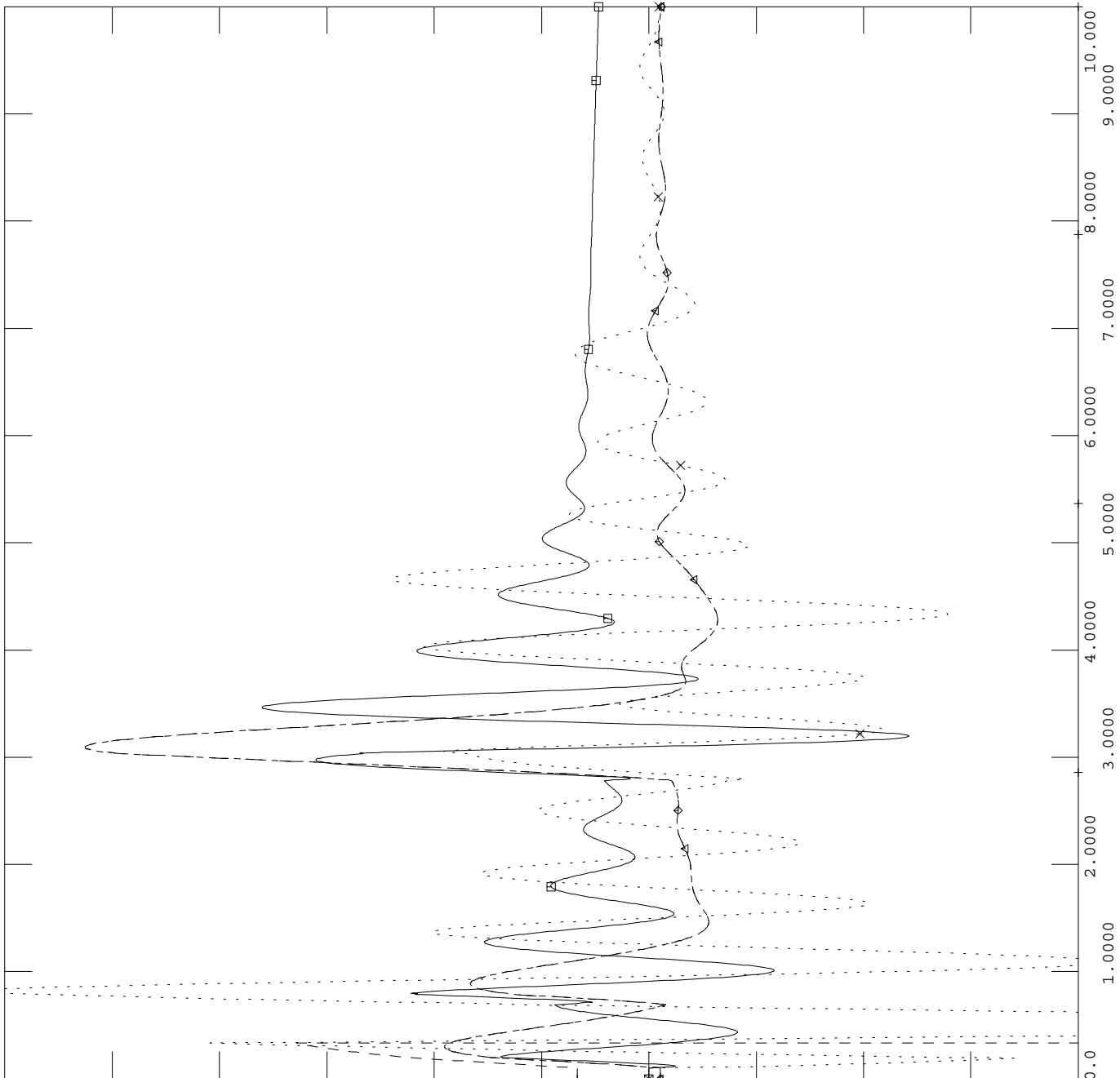

TUE, JUN 08 2004 16:47
OTHER GENERATOR SPEEDS



SPP MDWG 04 STABILITY;2005 SUMMER PEAK;S05SP-28.CNL;3-12-04
(C) 2004 SOUTHWEST POWER POOL, INC. (SEE DISCLAIMER BELOW)

FILE: FLT141PH.out

TUE, JUN 08 2004 16:47
NEW WIND GENERATOR

0.25000	CHNL# 409: [SPD 90090 [WFD WIND0.5750] [1]]	X-----X	0.19000
1.5000	CHNL# 411: [VARS 90090 [WFD WIND0.5750] [1]]	+-----+	0.0
1.5000	CHNL# 410: [POWR 90090 [WFD WIND0.5750] [1]]	◇-----◇	0.0
1.5000	CHNL# 406: [VOLT 90090 [WFD WIND0.5750]]	←-----→	0.0
1.5000	CHNL# 403: [VOLT 99996 [WFRDT 138.00]]	▣-----▣	0.0

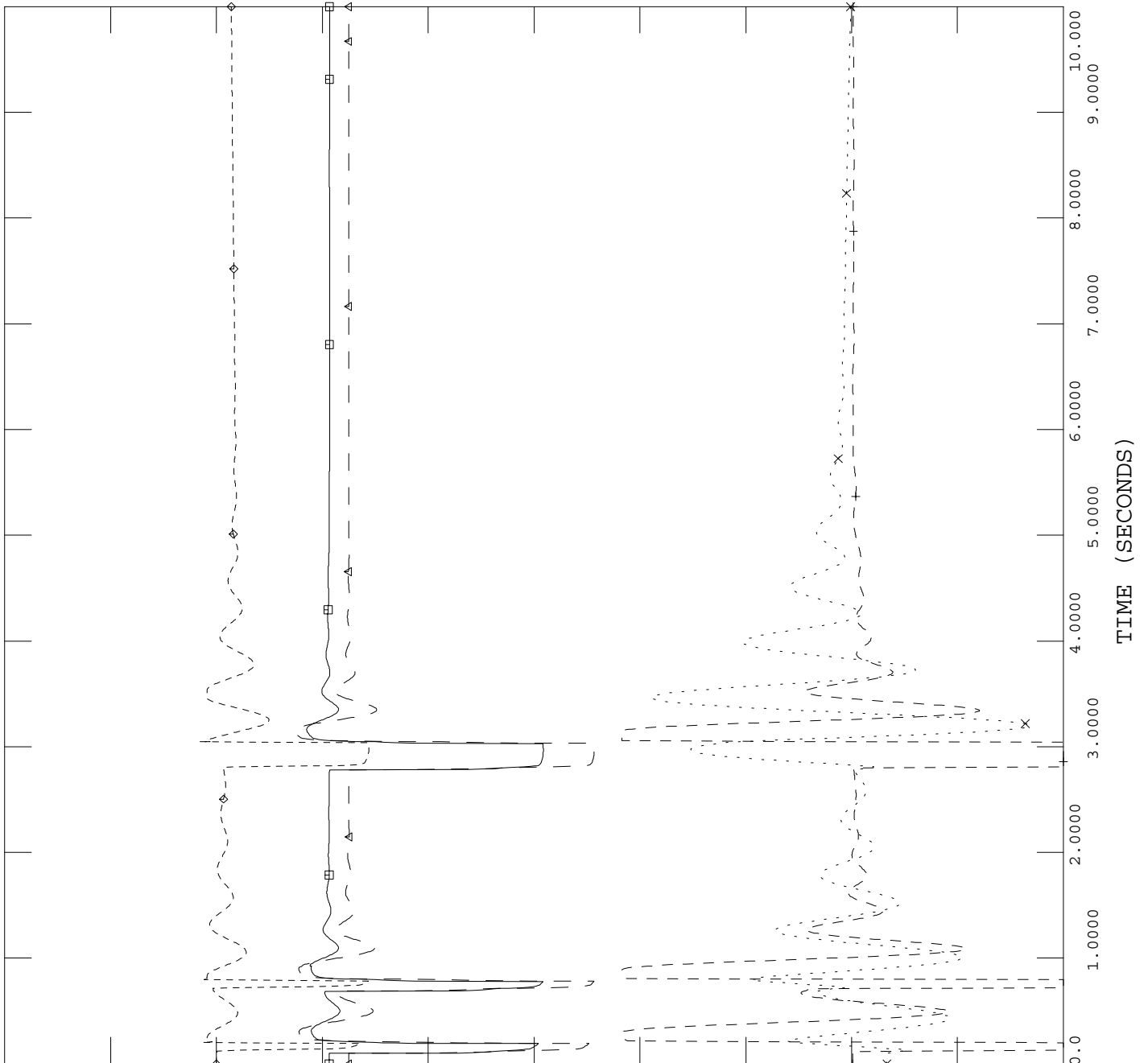



SPP MDWG 04 STABILITY;2005 SUMMER PEAK;S05SP-28.CNL;3-12-04
(C) 2004 SOUTHWEST POWER POOL, INC. (SEE DISCLAIMER BELOW)

FILE: FLT141PH.out

TUE, JUN 08 2004 16:47
OTHER GENERATOR SPEEDS

0.00150	CHNL# 402: [SPD 55997 [MORLND2 18.000] [1]]	x-----x	-0.0010
0.04000	CHNL# 401: [SPD 56007 [GEN-02-005 34.50] [1]	+-----+	-0.0100
0.02000	CHNL# 400: [SPD 56103 [GEN-03-005 138.00] [2]	◇-----◇	0.01000
0.02000	CHNL# 399: [SPD 56103 [GEN-03-004 138.00] [1]	←-----→	0.01000
0.20150	CHNL# 398: [SPD 55787 [GEN-03-022 0.5750] [1]	□-----□	0.19900

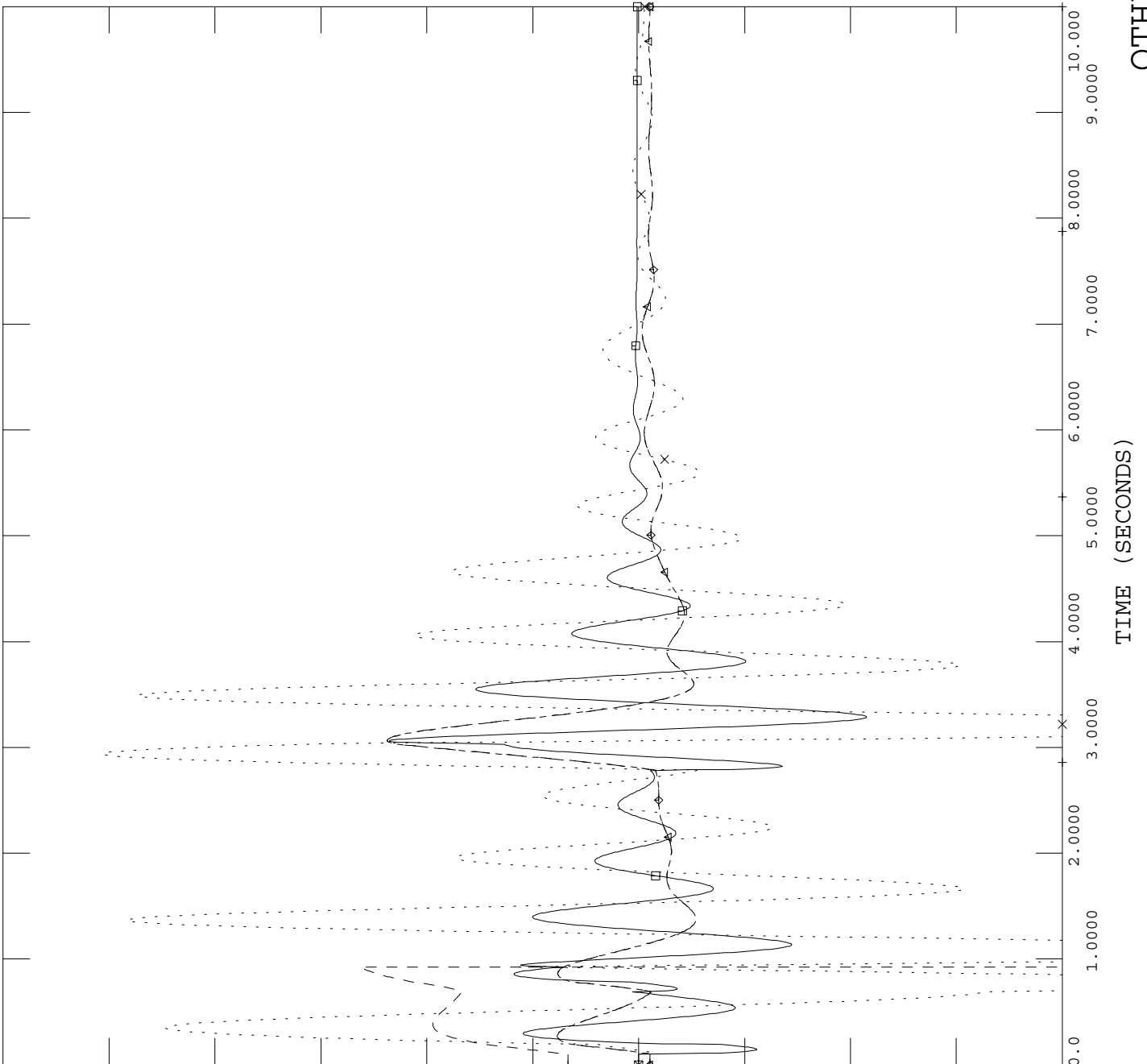



SPP MDWG 04 STABILITY;2005 SUMMER PEAK;S05SP-28.CNL;3-12-04
(C) 2004 SOUTHWEST POWER POOL, INC. (SEE DISCLAIMER BELOW)

FILE: FLT153PH.out

0.25000	CHNL# 409: [SPD 90090 [WFD WIND0.5750] [1]]	x-----x	0.19000
1.5000	CHNL# 411: [VARS 90090 [WFD WIND0.5750] [1]]	+-----+	0.0
1.5000	CHNL# 410: [POWR 90090 [WFD WIND0.5750] [1]]	o-----o	0.0
1.5000	CHNL# 406: [VOLT 90090 [WFD WIND0.5750]]	^-----^	0.0
1.5000	CHNL# 403: [VOLT 99996 [WFRDT 138.00]]	o-----o	0.0

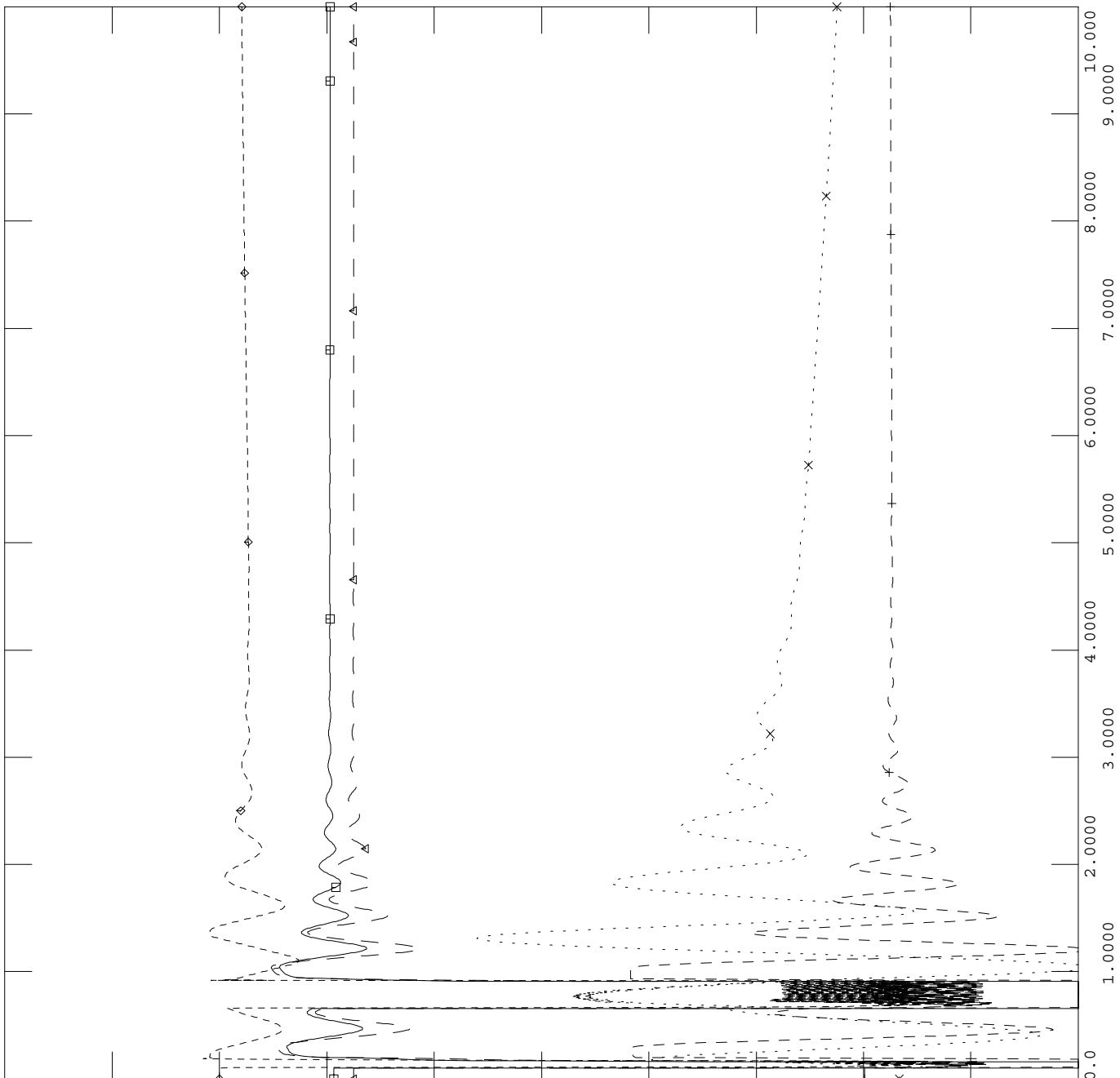

TUE, JUN 08 2004 16:47
NEW WIND GENERATOR



SPP MDWG 04 STABILITY;2005 SUMMER PEAK;S05SP-28.CNL;3-12-04
(C) 2004 SOUTHWEST POWER POOL, INC. (SEE DISCLAIMER BELOW)

FILE: FLT153PH.out

0.00150	CHNL# 402: [SPD 55997 [MORLND2 18.000] [1]]	x-----x	-0.0010
0.04000	CHNL# 401: [SPD 56007 [GEN-02-005 34.50] [1]	+-----+	-0.0100
0.02000	CHNL# 400: [SPD 56103 [GEN-03-005 138.00] [2]	o-----o	0.01000
0.02000	CHNL# 399: [SPD 56103 [GEN-03-004 138.00] [1]	←-----→	0.01000
0.20150	CHNL# 398: [SPD 55787 [GEN-03-022 0.5750] [1]	□-----□	0.19900

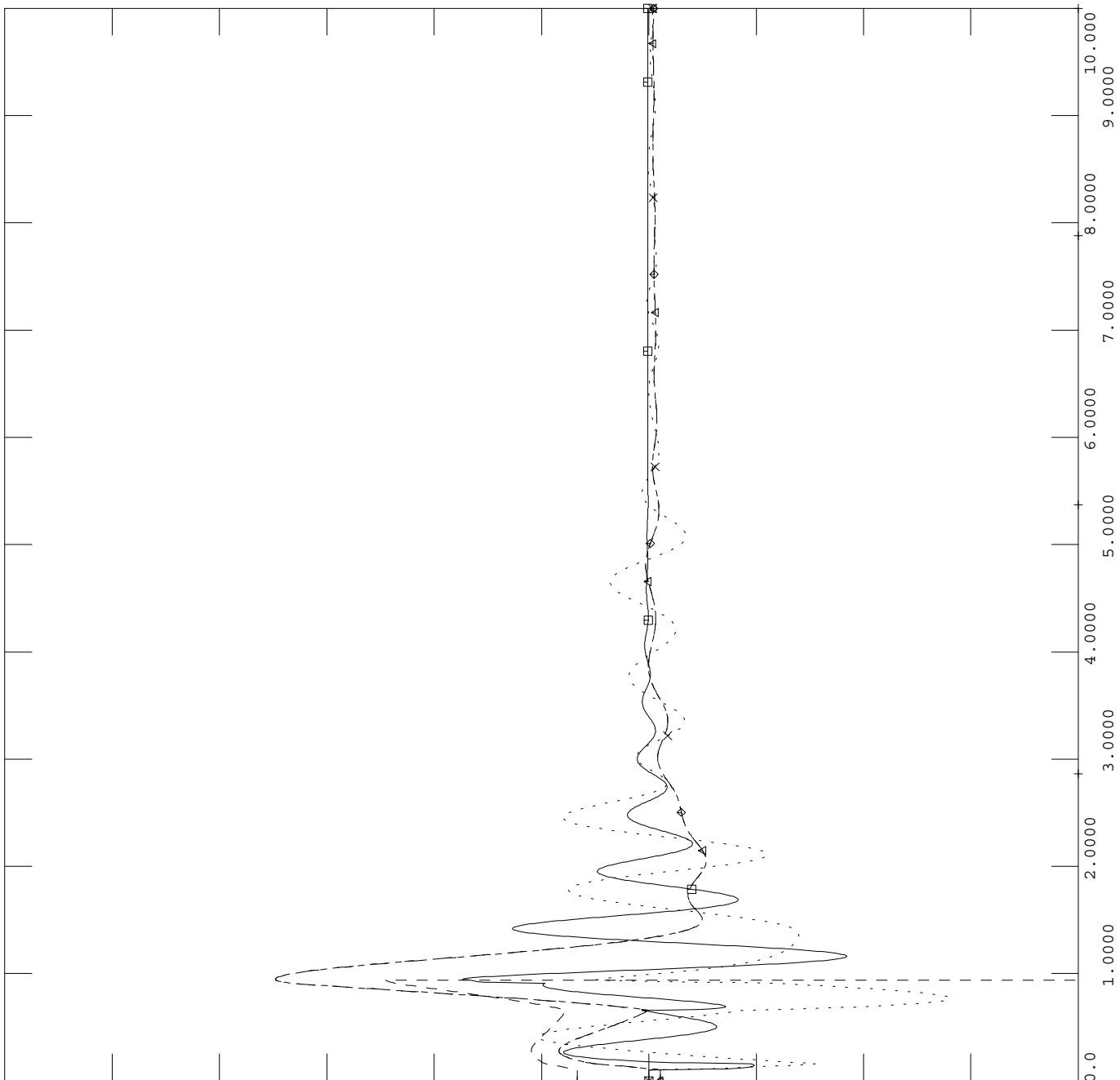

TUE, JUN 08 2004 16:47
OTHER GENERATOR SPEEDS



SPP MDWG 04 STABILITY;2005 SUMMER PEAK;S05SP-28.CNL;3-12-04
(C) 2004 SOUTHWEST POWER POOL, INC. (SEE DISCLAIMER BELOW)

FILE: FLT161PH.out

TUE, JUN 08 2004 16:47
NEW WIND GENERATOR

0.25000	CHNL# 409: [SPD 90090 [WFD WIND0.5750] [1]]	x-----x	0.19000
1.5000	CHNL# 411: [VARS 90090 [WFD WIND0.5750] [1]]	+-----+	0.0
1.5000	CHNL# 410: [POWR 90090 [WFD WIND0.5750] [1]]	◇-----◇	0.0
1.5000	CHNL# 406: [VOLT 90090 [WFD WIND0.5750]]	←-----△	0.0
1.5000	CHNL# 403: [VOLT 99996 [WFRDT 138.00]]	□-----□	0.0

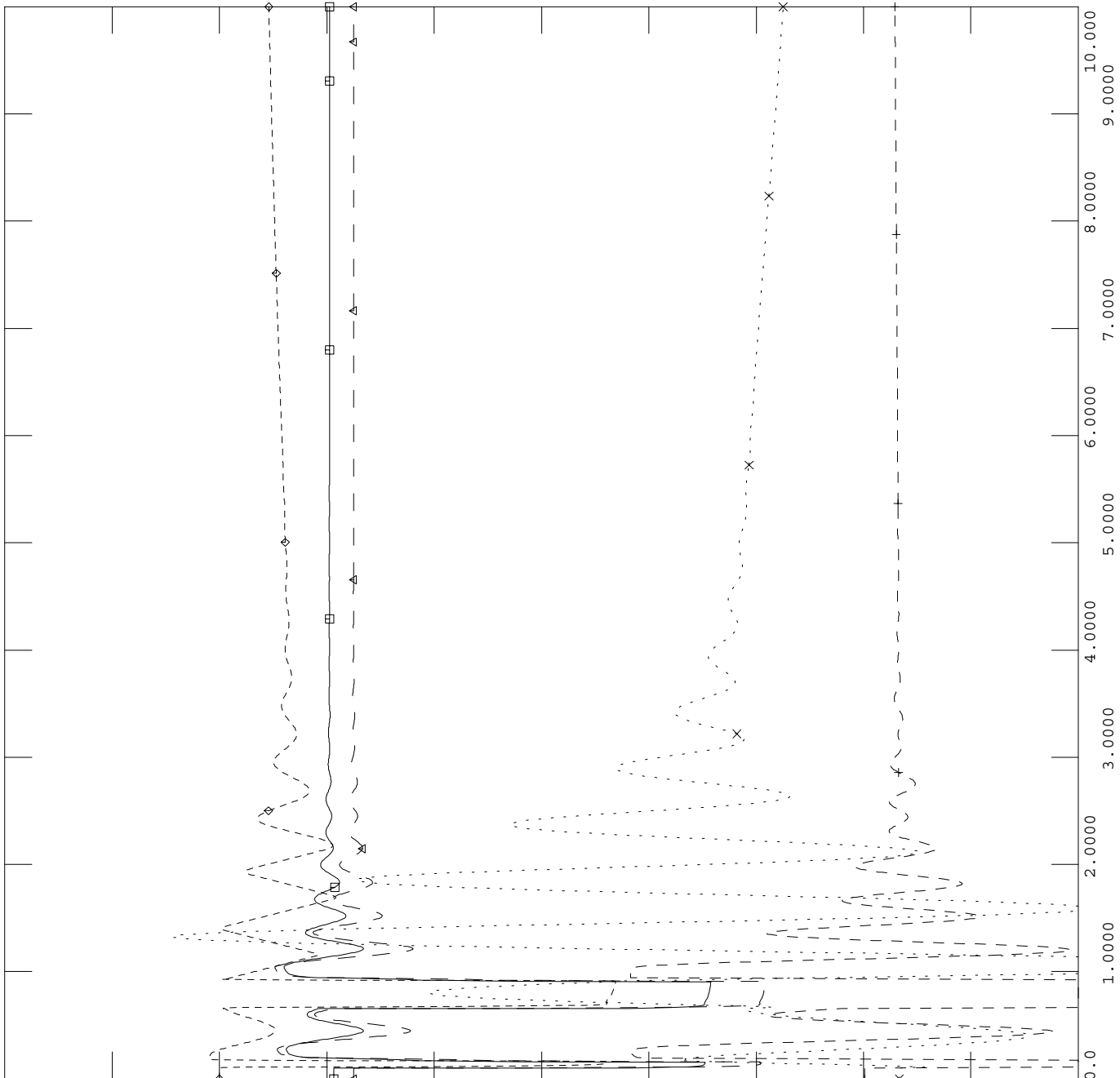



SPP MDWG 04 STABILITY;2005 SUMMER PEAK;S05SP-28.CNL;3-12-04
(C) 2004 SOUTHWEST POWER POOL, INC. (SEE DISCLAIMER BELOW)

FILE: FLT161PH.out

0.00150	CHNL# 402: [SPD 55997 [MORLND2 18.000] [1]]	x-----x	-0.0010
0.04000	CHNL# 401: [SPD 56007 [GEN-02-005 34.50] [1]	+-----+	-0.0100
0.02000	CHNL# 400: [SPD 56103 [GEN-03-005 138.00] [2]	◇-----◇	0.01000
0.02000	CHNL# 399: [SPD 56103 [GEN-03-004 138.00] [1]	←-----△	0.01000
0.20150	CHNL# 398: [SPD 55787 [GEN-03-022 0.5750] [1]	□-----□	0.19900

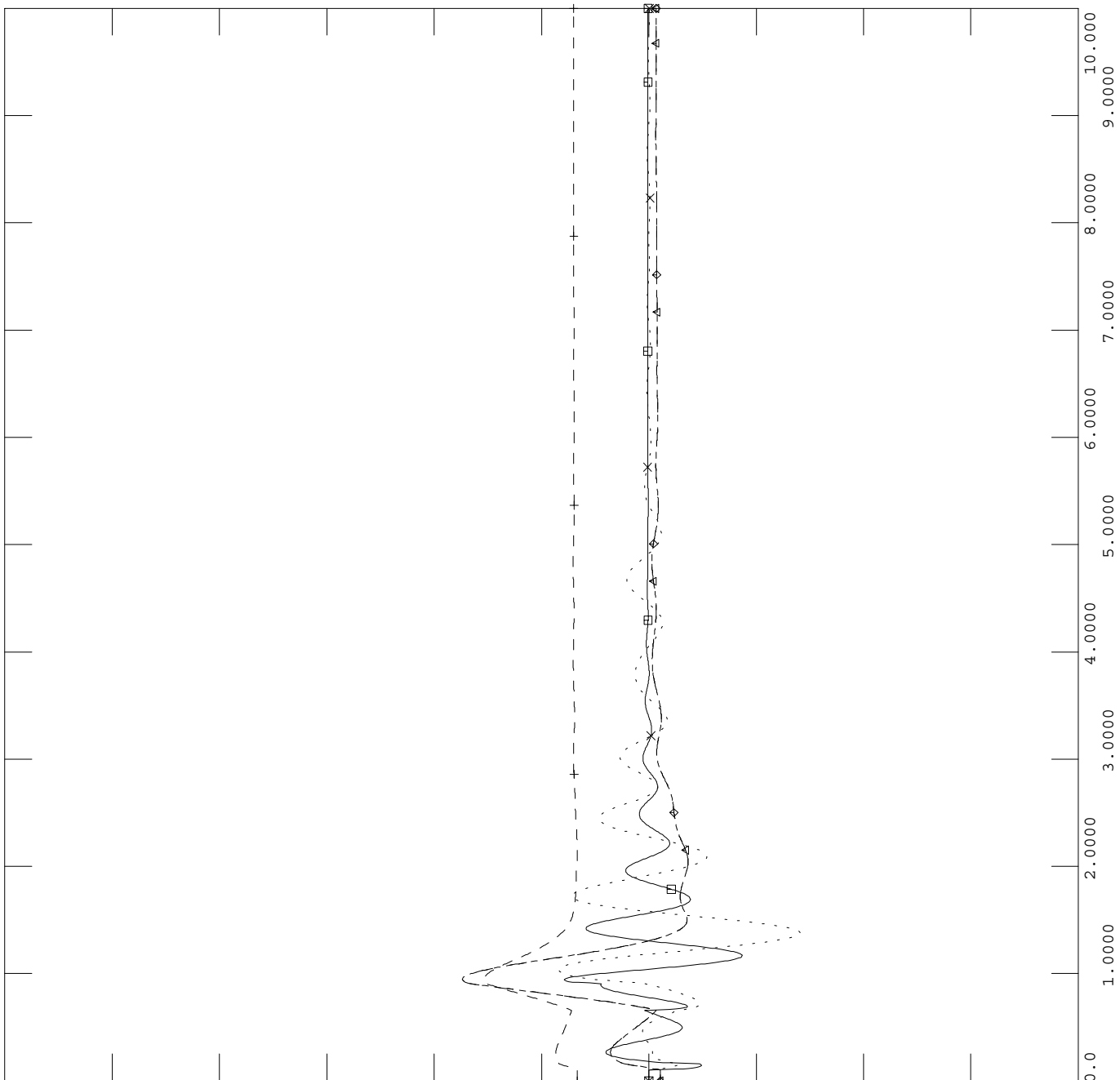

TUE, JUN 08 2004 16:47
OTHER GENERATOR SPEEDS



SPP MDWG 04 STABILITY;2005 SUMMER PEAK;S05SP-28.CNL;3-12-04
(C) 2004 SOUTHWEST POWER POOL, INC. (SEE DISCLAIMER BELOW)

FILE: FLT173PH.out

TUE, JUN 08 2004 16:47
NEW WIND GENERATOR

0.25000	CHNL# 409: [SPD 90090 [WFD WIND0.5750] [1]]	x-----x	0.19000
1.5000	CHNL# 411: [VARS 90090 [WFD WIND0.5750] [1]]	+-----+	0.0
1.5000	CHNL# 410: [POWR 90090 [WFD WIND0.5750] [1]]	o-----o	0.0
1.5000	CHNL# 406: [VOLT 90090 [WFD WIND0.5750]]	^-----^	0.0
1.5000	CHNL# 403: [VOLT 99996 [WFRDT 138.00]]	o-----o	0.0

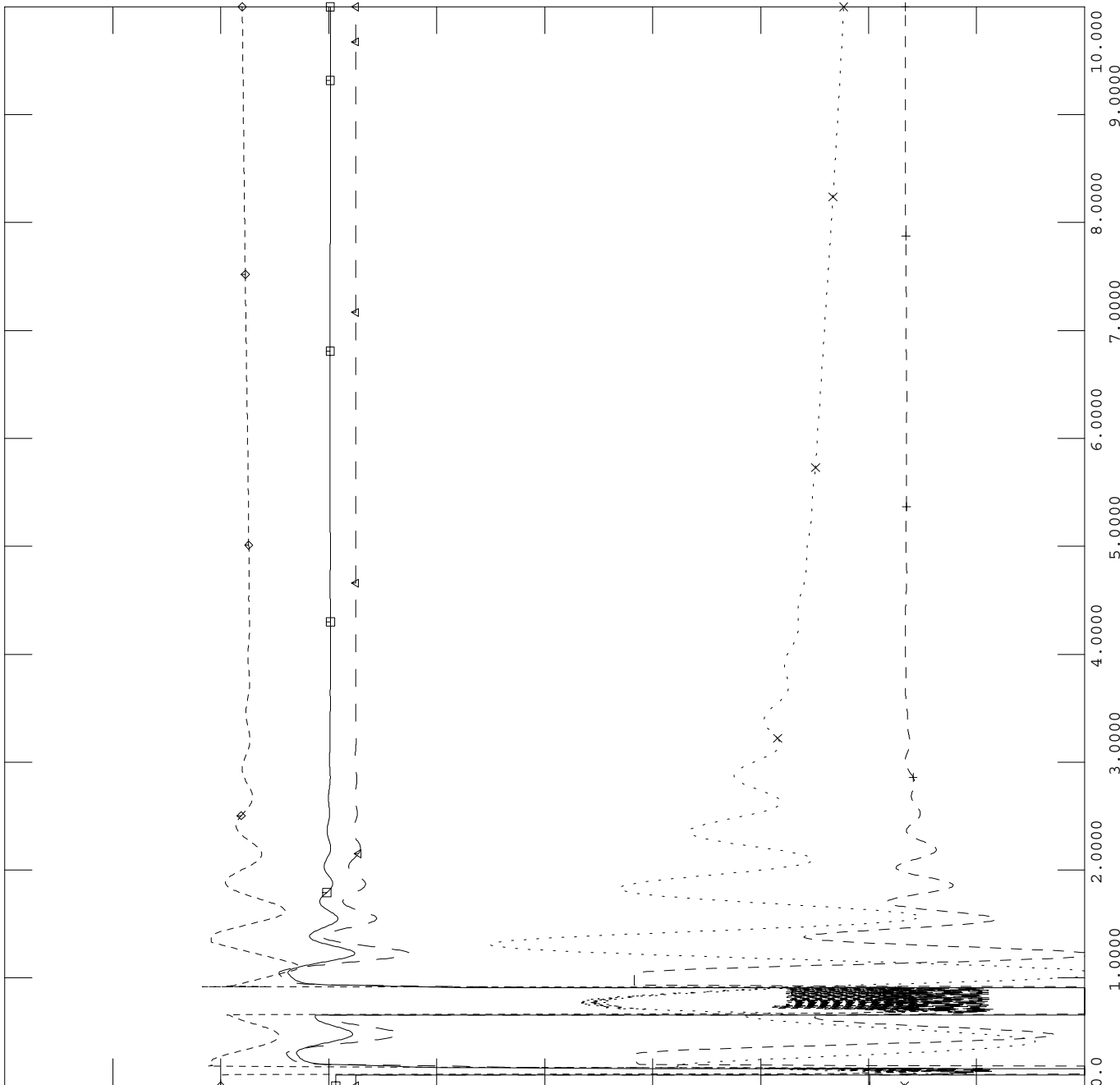



SPP MDWG 04 STABILITY;2005 SUMMER PEAK;S05SP-28.CNL;3-12-04
(C) 2004 SOUTHWEST POWER POOL, INC. (SEE DISCLAIMER BELOW)

FILE: FLT173PH.out

0.00150	CHNL# 402: [SPD 55997 [MORLND2 18.000] [1]]	x-----x	-0.0010
0.04000	CHNL# 401: [SPD 56007 [GEN-02-005 34.50] [1]	+-----+	-0.0100
0.02000	CHNL# 400: [SPD 56103 [GEN-03-005 138.00] [2]	◇-----◇	0.01000
0.02000	CHNL# 399: [SPD 56103 [GEN-03-004 138.00] [1]	←-----→	0.01000
0.20150	CHNL# 398: [SPD 55787 [GEN-03-022 0.5750] [1]	□-----□	0.19900

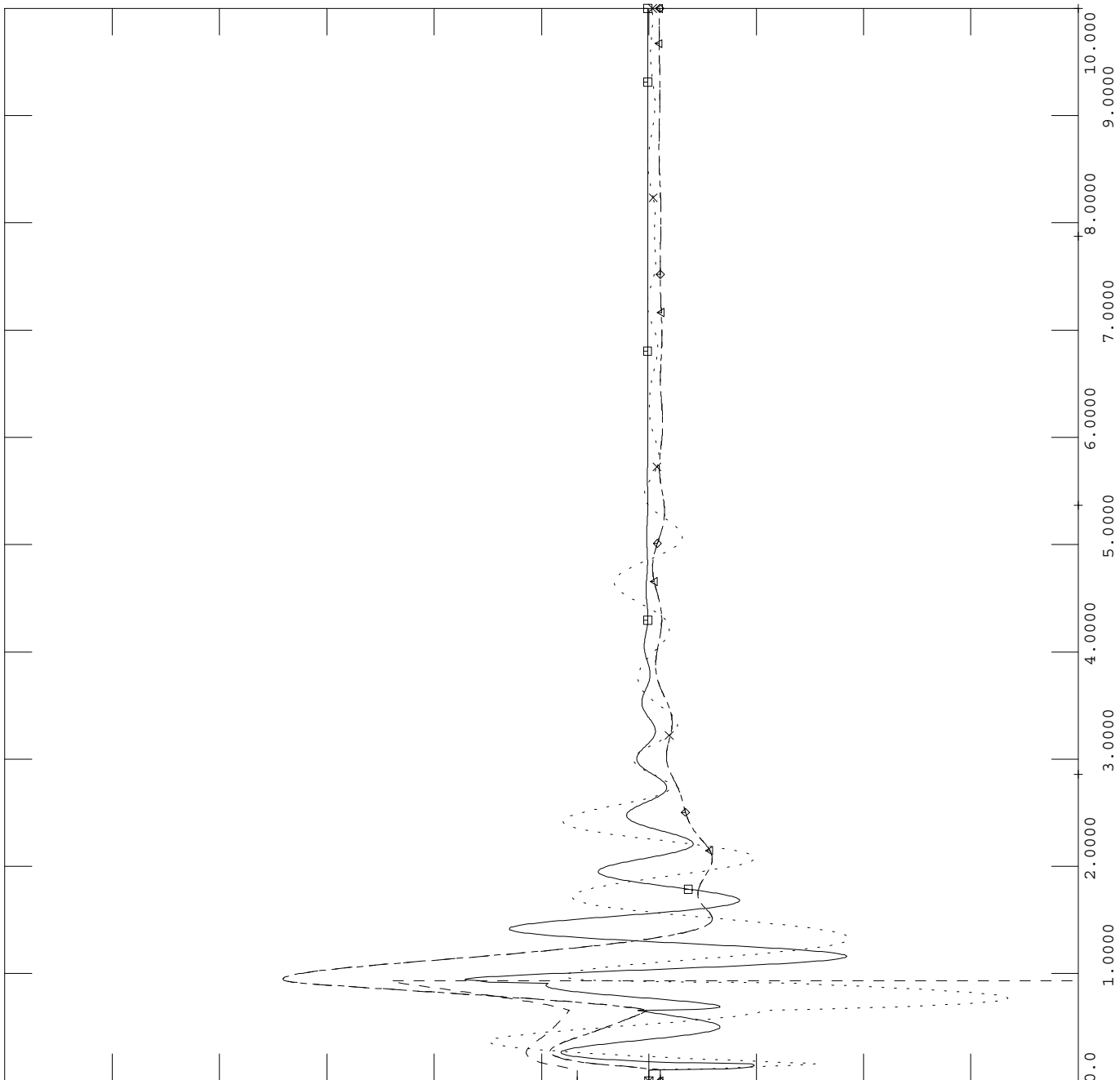

TUE, JUN 08 2004 16:47
OTHER GENERATOR SPEEDS



FILE: FLT181PH.out

TUE, JUN 08 2004 16:47
NEW WIND GENERATOR

0.25000	CHNL# 409: [SPD 90090 [WFD WIND0.5750] [1]]	x-----x	0.19000
1.5000	CHNL# 411: [VARS 90090 [WFD WIND0.5750] [1]]	+-----+	0.0
1.5000	CHNL# 410: [POWR 90090 [WFD WIND0.5750] [1]]	◇-----◇	0.0
1.5000	CHNL# 406: [VOLT 90090 [WFD WIND0.5750]]	←-----△	0.0
1.5000	CHNL# 403: [VOLT 99996 [WFRDT 138.00]]	□-----□	0.0

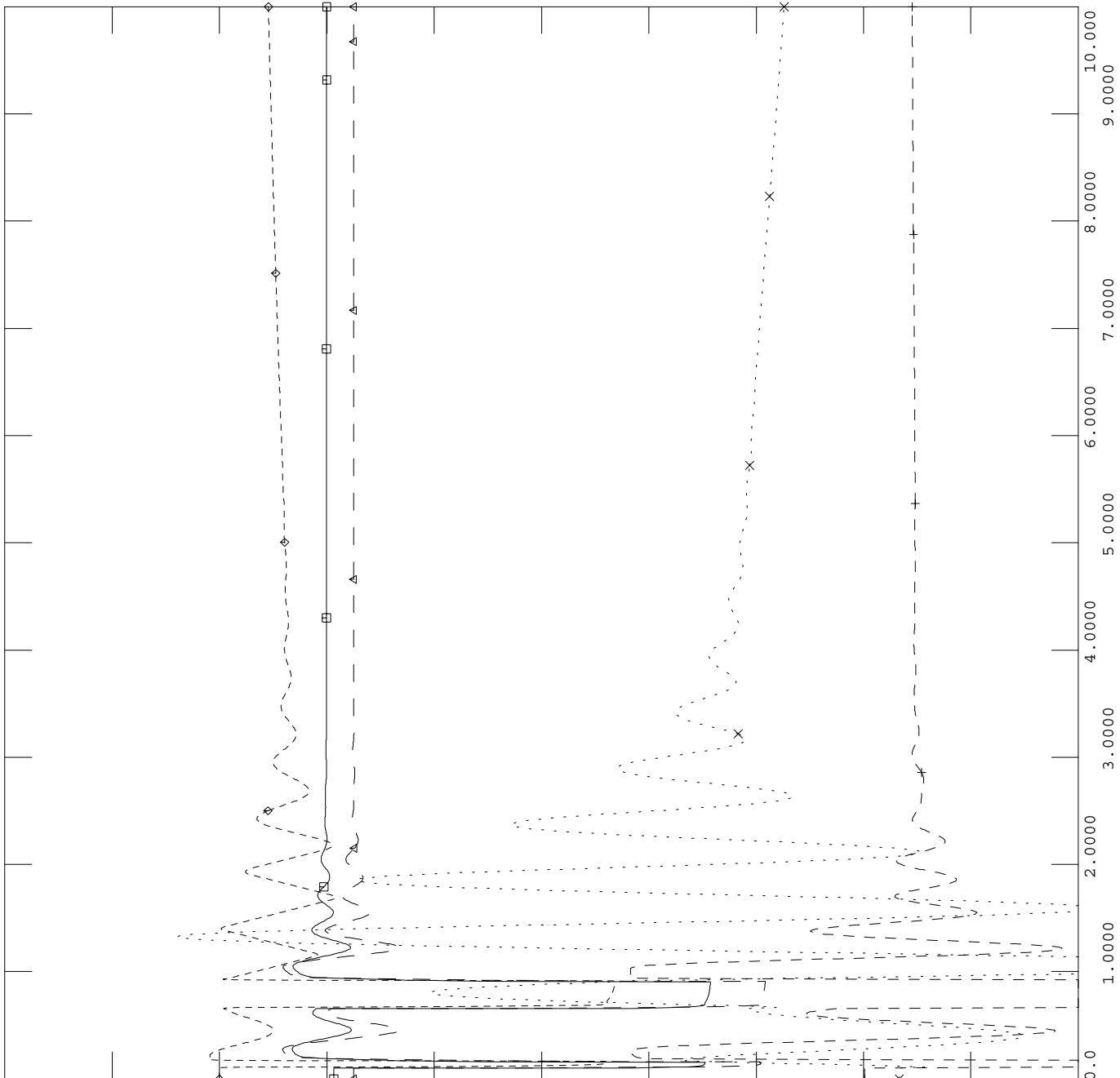



SPP MDWG 04 STABILITY;2005 SUMMER PEAK;S05SP-28.CNL;3-12-04
(C) 2004 SOUTHWEST POWER POOL, INC. (SEE DISCLAIMER BELOW)

FILE: FLT181PH.out

0.00150	CHNL# 402: [SPD 55997 [MORLND2 18.000] [1]]	x-----x	-0.0010
0.04000	CHNL# 401: [SPD 56007 [GEN-02-005 34.50] [1]	+-----+	-0.0100
0.02000	CHNL# 400: [SPD 56103 [GEN-03-005 138.00] [2]	◇-----◇	0.01000
0.02000	CHNL# 399: [SPD 56103 [GEN-03-004 138.00] [1]	←-----→	0.01000
0.20150	CHNL# 398: [SPD 55787 [GEN-03-022 0.5750] [1]	□-----□	0.19900

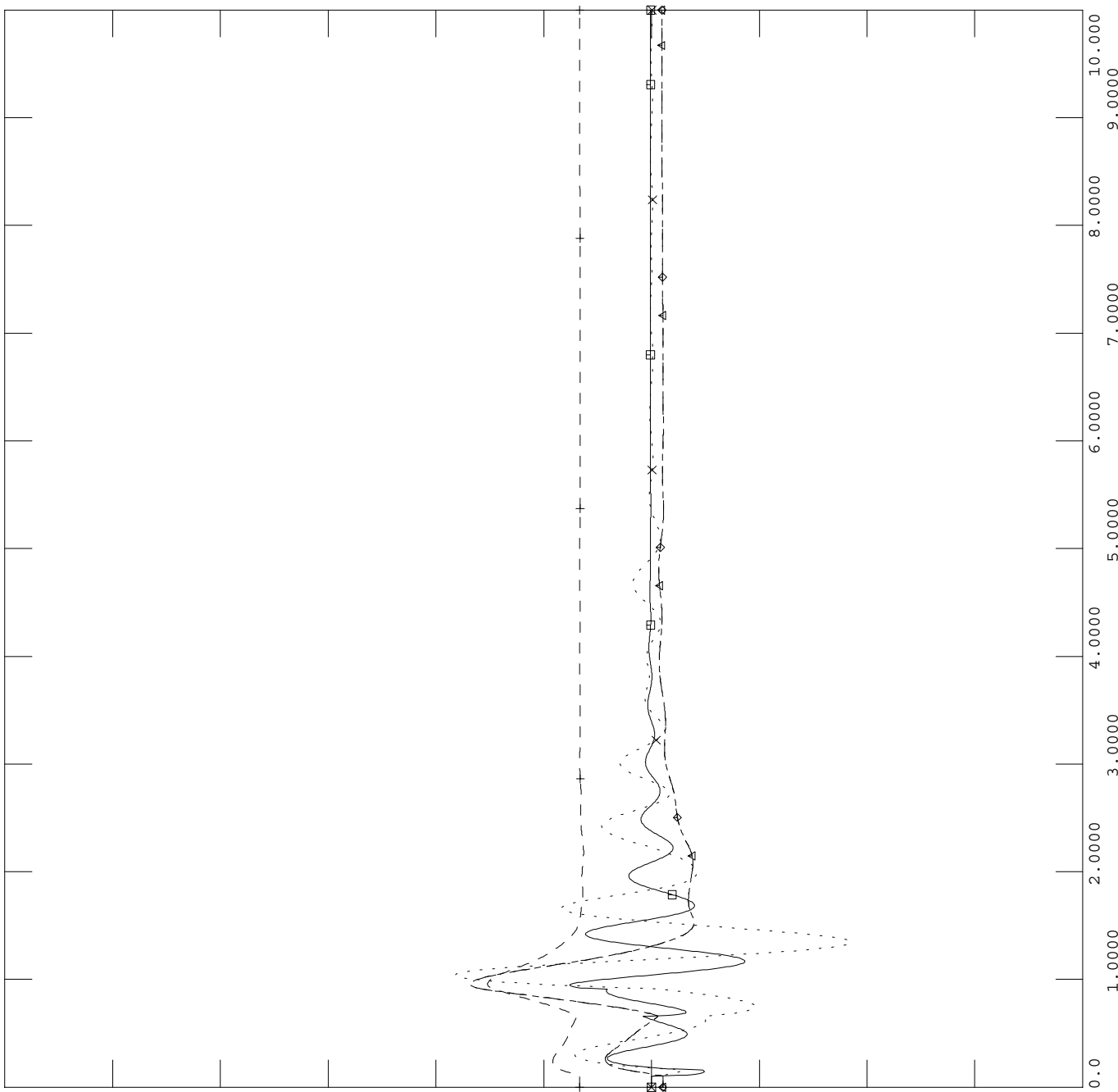

TUE, JUN 08 2004 16:47
OTHER GENERATOR SPEEDS