



***Facility Study for Generation
Interconnection Request
GEN – 2003 – 013***

***SPP Coordinated Planning
(#GEN-2003-013)***

June 2005

Summary

Xcel Energy performed the following study at the request of the Southwest Power Pool (SPP) for SPP Generation Interconnection request Gen-2003-013. The request for interconnection was placed with SPP in accordance SPP's Open Access Transmission Tariff Attachment V, which covers new generation interconnections on SPP's transmission system.

Pursuant to the tariff, Xcel Energy was asked to perform a detailed Facility analysis of the generation interconnection requests to satisfy the Facility Study Agreement executed by the requesting customer and SPP.

Based on the results of the Facility Study and the EMPT study certain parts of the Impact study will need to be re-run to verify there is no negative effects due to the installation of one (1) non-switchable 50 MVAR line reactor at the new switching station, or two (2) non-switchable 27 MVAR line reactors if the construction of the higher queued Generation Interconnection Request on the 345 kV transmission circuit is also built.



**Facilities Study
For
GEN-2003-013**

198 MW Wind-Generated Energy Facility
Stevens County, Kansas

SPP #GEN-2003-013

June 21, 2005

Xcel Energy Services, Inc.
Transmission Planning

Executive Summary

>Omitted Text< (the “Requester”) has requested the interconnection of a wind energy facility to a Southwestern Public Service Company (SPS) (d/b/a Xcel Energy, Inc) 345 kV transmission line. This facility will interconnect to the 345 kV transmission circuit between Potter County Interchange, in Amarillo, TX and Finney Switching Station in southwestern Kansas. The Southwest Power Pool (SPP) evaluated the request to interconnect this wind energy facility to the SPS transmission system in a System Impact Study completed June 2004. This wind energy facility will consist of 132 individual GE 1.5sL wind turbines with a rated output of 1.5 MW each, with the nominal output of this facility being 198 MW.

A new switching station will be constructed that will tap the existing SPS 345 kV transmission circuit J03 between Potter County Interchange and Finney Switching Station. The new switching station on this transmission circuit is approximately 60 circuit miles south of Finney Switching Station. The new switching station will consist of a 345 kV ring bus with a 345 kV terminal for the Requester’s transmission line, from the wind farm, allowing for the transmission of wind energy from the Requester’s substation to the SPS transmission grid.

The results of the EMTP¹ Study recommend the installation of one non-switchable 50 MVA line reactor located at the new switching station, or two non-switchable 27 MVA line reactors if the construction of a higher queued Generator Interconnection Request on this 345 kV transmission circuit is also built. See Section 6 for details.

A Certificate of Convenience and Necessity (CCN) from the Public Utility Commission of Kansas is not required for the construction of the new switching station.

Xcel Energy will require the Interconnection Customer to construct the Interconnection Facilities in compliance with the latest revision of the Xcel Energy Interconnection Guidelines for Transmission Interconnection Producer-Owned Generation Greater than 20 MW. This document describes the requirements for connecting new generation to the Xcel Energy operating company transmission systems including technical, protection, commissioning, operation, and maintenance. Xcel Energy will also require that the Interconnection Customer be in compliance with all applicable criteria, guidelines, standards, requirements, regulations, and procedures issues by the North American Electric Reliability Council, (NERC), Southwest Power Pool, and Federal Energy Regulatory Commission or their successor organizations.

The Requester is responsible for the cost of the Requester’s Interconnection Facilities, inclusive of all construction required for the 345 kV transmission line from the Requester’s substation to the new SPS switching station.

If the Requester chooses to proceed with an Interconnection Agreement, a revision to the latest System Impact Study will be required. The revision is required to establish or dismiss the presence of new stability impacts arising from the addition of the non-switchable line reactors recommended in the EMTP study results.

The customer has requested an in-service date of 12/1/2005, which will need to be revised by the customer as a result of construction schedules. Additionally, it is anticipated that the construction of the new switching station, for the acceptance of wind generated electric energy from the Requester’s Wind Farm, will require approximately 16 months for completion. The cost of these upgrades, inclusive of the Requester’s cost for the Interconnection Facilities required for the interconnection of this new wind energy generation facility, is shown below:

Table 1, Cost Summary

Stand-alone Network Upgrade ² :	\$5,866,765
Network Upgrade:	\$675,000
Interconnection Facilities ³ :	\$95,000
Total ⁴ :	\$6,636,765

¹ Electromagnetic Transient Program

² Add \$828,672 to the total cost, as a result of cost difference for line reactors, if a higher queued project is added to this 345 kV transmission circuit.

³ This is a direct assigned cost to the Requester.

⁴ The cost values are 2005 dollars with an accuracy level of ±20%.

The cost figures shown in Table 1 are solely for the interconnection of this wind energy facility to the Xcel Energy transmission system. They do not reflect costs for transmission system upgrades related to any request made for network transmission service. A detailed description of all costs associated with the construction of this new SPS switching station is shown in Table 4.

Discussion

General Description of Facilities

The new switching station required to connect the Requester's wind-generated energy facility will be located adjacent to the existing Potter County Interchange to Finney Switching Station 345 kV transmission line. The new switching station will consist of a three breaker 345 kV ring bus design with expansion capability to a breaker and a half configuration. The existing transmission line will be routed in and out of the new switching station with 345 kV breakers on both lines towards Potter County and Finney, and on the new customer owned 345 kV transmission line.

General Description of Modifications and New SPS⁵ Facilities

1. Construction of New Switching Station

See Figure A - 2 in Appendix A for one-line diagram and Figure A - 5 for a plan view of the station.

- 1.1. **Location:** The new 345 kV switching station will be constructed at the interception point to the Xcel Energy transmission circuit J03, located approximately 60 circuit miles south of the Finney Switching Station. See Figure A - 1 for a map of the area.
- 1.2. **Bus Design:** The 345 kV ring bus will be built as a 3-breaker ring expandable to a 2 string breaker-and-a-half with 4 terminals. In the switching station there will be three dead-end towers on the 345 kV, 11 switches on structures, three sets of 345 kV potential transformers (PT) on stands, and one 345 kV PT will be installed as a backup power source for station power.
- 1.3. **Control House:** A control house approximately 24 feet by 36 feet will be installed to contain the metering, protection and control devices, terminal cabinets, and any fiber-optic cable terminations, etc.
- 1.4. **Line Reactors:** One non-switchable 50 MVAR line reactor will be installed at the new switching station. The reactor will be connected to the 345 kV line towards Potter County Interchange. If a higher queued project in the SPP interconnection queue is built on this same 345 kV transmission circuit, this reactor will be replaced as recommended by the EMTP study results; see Section 6 for details.
- 1.5. **Security Fence:** The switching station will have a 7-foot chain-link fence with steel posts set in concrete, with 1-foot of barbed wire on the top in a "V" configuration. The enclosed area will be approximately 700' x 450', with a rock yard surface.
- 1.6. **Ground Grid:** A complete ground-grid will be installed per ANSI/IEEE STD 80-2000, with our standard 4/0 copper ground mesh on 40-foot centers with ground rods and 20-foot centers in corners and loop outside of fence.
- 1.7. **Site Grading:** Company contractor, per company specifications, will perform initial site grading and erosion control of the new switching station. Soil compaction shall be not less than 95% of laboratory density as determined by ASTM-D-698.

⁵ All modifications to SPS facilities will be owned, maintained and operated by SPS.

- 1.8. **Station Power:** A 199kV/120-240 volt transformer tapped off of the 345 kV bus will provide station power. A backup station power source will be taken from local distribution, if it is available, or a generator will be installed if no distribution service is available. Additionally, a flip-flop to automatically transfer the station power will be installed.
- 1.9. **Relay and Protection Scheme:** The new switching station to the Potter County 345 kV line relaying will be directional comparison unblocking over power line carrier with a Pulsar TFC10B. A SEL 321-1 and a separate segregated phase comparison transmission line protection system with distance backup protection will be used with a leased phone circuit. An SEL 279H-2 with a SEL 351 relay will be used for sync check and re-closing, along with an SEL 501-0 for breaker failure. The new terminal will preserve the existing capability of high speed single pole tripping.

The new switching station to Finney Switching Station 345 kV line relaying will utilize the same type of equipment as that of the Potter County 345 kV line.

On both the Potter County and Finney Switching Station lines there will be three coupling capacitor voltage transformers (CCVT) for line conditions. Line tuning units and wave traps will also be installed for the power line carrier communications.

A transfer trip scheme will be installed such that for any line dropping or fault clearing of either line from the new switching station to Potter County or Finney, the appropriate breaker(s) at the new switching station will be opened first. Additionally, a switching scheme that checks that the appropriate breaker(s) at Potter County or Finney are closed prior to closing any line breaker(s) at the new switching station will also be installed. This is required to avoid reclosing or energizing of these lines from the new switching station as recommended in the results of the EMTP study.

The batteries will be our standard set of 306 or 204 AH Varta batteries with a 35 or 25 amp charger.

At Potter County or Finney, carrier frequencies will need to be changed on the existing wave traps and line-tuning units, to maintain carrier frequency separation. Additionally, one line terminal may require changing if compatible relays cannot be located.

- 1.10. **Revenue Metering:** On the 345 kV line from the Requester's substation, a billing meter will be installed along with an ION 8400 meter unit, ANSI C12.1 accuracy class 0.2 (3 PTs IEEE C57.13 accuracy class 0.3 and 3 CTs IEEE C57.13 accuracy class 0.15) for full 3 phase 4-wire metering. The metering unit will have 3000/1800:1 PTs and 200/400:5 CTs. There will be two meters one will be primary and the other will be back-up, and each will have full 4 quadrant metering. Pulses out of the primary billing meter will be sent via SCADA to the Amarillo Control Center. Metering at this new switching station will be installed to comply with present SPP market protocols.
- 1.11. **Disturbance Monitoring Device:** Disturbance-monitoring equipment, capable of recoding faults, swings, and long term trending, will be installed to monitor and record conditions in the substation and on the transmission lines. This equipment will have communication capability with a dedicated communication circuit. The Disturbance equipment shall also be equipped with a GPS time synchronizing clock.
- 1.12. **Communications:** A 4-wire conditioned 56K phone circuit will be required between the new switching station and both Potter County Interchange and Finney County substation, which will provide communications for line relaying.

The RTU will be our standard large 5700 RTU with communications. An SEL 2020 will be installed for relay communications and other functions as required.

Communications from the switching station to the Amarillo Control Center will consist of a 4-wire analog telephone data circuit provided by the Requester, if it is available. If it is not available, some type of communications will have to be installed, at the Requester's expense, to get the metering data to the Amarillo Control Center, along with the RTU information.

A station telephone will be installed in the control house. A telephone switch will be installed to transfer between the SEL-2020 and the billing meters along with the station talk service.

A schematic outlining the proposed communications is provided below:

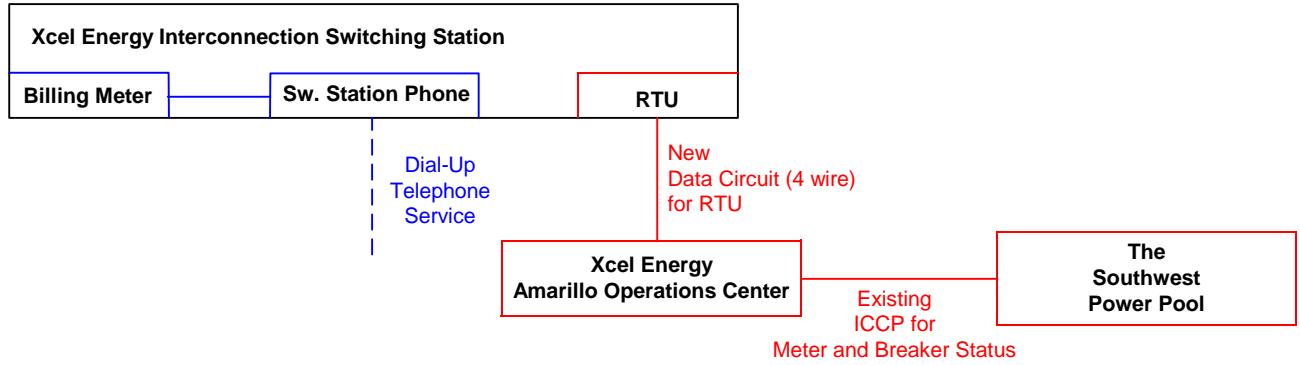

2. Transmission Line

The Requester will construct, own, operate, and maintain the new customer owned 345 kV transmission line from the Requester's substation to this new SPS switching station. Figure A - 4 shows the Point of Interconnection and Change of Ownership. ***The Xcel Energy transmission design group prior to any construction by the Requester or its contractor on the customer owned 345kV transmission line, or doing work in close proximity to any SPS transmission line, will require an engineering review of the customer's design. It is the Requester's responsibility to initiate the design review in a timely manner before construction of the 345kV transmission line begins. If the review has not been made or the 345 kV design is deemed inadequate, the termination into the new switching station will be delayed until the matters are resolved. Xcel Energy will not be held responsible for these delays.***

- 2.1. **345 kV Line Taps:** The existing Xcel Energy overhead 345 kV transmission line (J03) will be tapped in and out of the new switching station centered on structure 796. The location is the SW 1/4 of Section 21, T-32-S, R-36-W Stevens County, Kansas, with the GPS coordinates of the structure being 37°14'44.79"N, 101°14' 54.39"W, and located on the east side of Rd. 18 approximately 1200' north of Rd. T.

Two overhead 345 kV taps will be constructed on the north and south sides of the switching station, dead-ending on 345 kV terminals within the new switching station. The existing 345 kV line between these two tap points will be removed such that power flows in and out of the proposed switching station. See Figure A - 3.

The 345 kV Requester's transmission lines shall maintain proper clearance above the 345 kV bus at the new switching station. An Xcel Energy inspector will have final authority on whether proper clearance above the new switching station bus has been maintained.

3. Right-Of-Way

- 3.1. **New 345 kV Transmission Line Taps:** See Figure A - 3 for location of line taps relative to switching station site.
- 3.2. **Permitting:** Currently, permitting for the construction of the new switching station is not required in the State of Kansas.
- 3.3. **Switching Station Location:** The new switching station will be constructed adjacent to the existing 345 kV transmission circuit J03, assuming the land can be procured from the landowner.

4. Construction Power and Distribution Service

It is the sole responsibility of the Requester to make arrangements for both construction and station power which may be required for the Requester's wind energy facility. Additionally, if the Requester's substation(s) and/or construction site(s) lie outside of the Xcel Energy service area, Xcel Energy cannot provide station power (retail distribution service) and the Requester needs to make arrangements for distribution service from the local retail provider.

5. Project and Operating Concerns

Close work between the Transmission group, the Requester's Personnel and local operating groups will be imperative to have this project in service on the scheduled date.

6. EMTP Study Results

The results of the EMTP study recommend a non-switchable 50 MVAR line reactor needs to be installed at the new switching station. The non-switchable line reactor will be installed on the 345 kV transmission circuit towards Potter County Interchange. If the construction of a higher queued project on this 345 kV transmission circuit is also built,

two non-switchable 27 MVAR line reactors are recommended at each end of the transmission line between the new switching station and the switching station for the higher queued request. The two 27 MVAR reactors will be installed instead of the single 50 MVAR reactor. Figure A - 6 and Figure A - 7 are included to illustrate the location of these reactors.

7. Fault Current

Table 2 below shows the available fault current on the 345 kV bus at this new switching station location. The fault current shown is before the addition of this wind farm; any contribution to the fault current from the wind farm is not included in the values below.

Table 2, Available Fault Current At Switching Station 345 kV Bus

Fault Type	Amps	MVA
Three Phase	3815.35	2279.89
Single-Line-To-Ground	2810.73	1679.57

Table 3, Source Impedance⁶ Data At Switching Station 345 kV Bus

Positive (Z^+)	Zero (Z^0)
0.00334 +j 0.04373	0.02130 +j 0.08894

8. Estimated Construction Costs

The projects required for the interconnection of the 198 MW wind energy generating facility consist of the projects summarized in the table below:

Table 4, Required Interconnection Projects

Project	Description	Estimated Cost
	Stand-alone Network Upgrade	
1	Ring Bus, 345 kV	\$ 4,002,486
2	Line Reactor, 345 kV (50 MVAR) ⁷	\$ 1,664,279
3	Disturbance Monitoring Device	\$ 100,000
4	Right-of-Way Cost (station land, surveying, etc.)	\$ 100,000
	Subtotal:	\$5,866,765
	Network Upgrade	
5	Relay Modifications, Potter County and Finney Station	\$ 200,000
6	345 kV Transmission Line Work	\$ 475,000
	Subtotal:	\$675,000
	Interconnection Facilities⁸ (at the Requester's Expense)	
7	345 kV Arresters	\$ 10,000
8	Communications Cost (Metering, RTU, etc.)	\$ 85,000
	Subtotal:	\$95,000
	Total Cost⁹:	\$6,636,765

⁶ Values are in per-unit on a 100 MVA base.

⁷ See section 6 for details.

⁸ This is a direct assigned cost to the Requester.

If a higher queued project ahead of this request in the SPP Generation Interconnection queue is interconnected to this same 345 kV transmission circuit, project 2 in Table 4 will change to the installation of two non-switchable 27 MVAR line reactors. These two 27 MVAR reactors, in place of the 50 MVAR reactors, are required as recommended by the EMTP Study and the cost of project 2 in Table 4 will be \$2,492,951 for the two 27 MVAR reactors. Thus the total cost to interconnect this 198 MW wind generated energy facility could increase by \$828,672.

9. Requirements For Requester

In addition to requirements previously mention, it is a requirement that the Requester install a breaker on the high side of their substation that looks towards the new Xcel Energy switching station. The breaker should be capable of interrupting full load current as well as fault current at the Requester’s bus.

Engineering and Construction Schedule

It is anticipated that the switching station and all associated components will be constructed and ready to receive power from the Requester’s wind farm approximately 16 months from the day an interconnection agreement is signed, unless prior arrangements have been made. This is the earliest Xcel Energy can complete the project as a result of other scheduling considerations. An Engineering and Construction schedule is shown below:

ID	Task Name	Duration	Year 1												Year 2								
			9	10	11	12	1	2	3	4	5	6	7	8	9	10	11	12	1	2	3	4	5
1	Right-of-Way Process	50 days																					
2	Obtain Substation Site	8 wks				1/5																	
3	Right-of-Way Completion	2 wks																					
4																							
5	Substation - Switching Station Project	339 days																					
6	Preliminary Engineering	4 wks				1/5																	
7	Order Transformer	14 mons																					
8	Substation site Survey	2 wks																					
9	Dirt prints complete	10 wks				1/5																	
10	Dirt bids	2 wks																					
11	Dirt pad & road work	6 wks																					
12	Material order & delivery	24 wks																					
13	Manifest Construction drawings	12 wks				1/5																	
14	Fence Construction	3 wks																					
15	Foundation work complete	8 wks																					
16	Substation construction	16 wks																					
17	Testing and inspection	1 wk																					
18	Commission Substation	2 wks																					
19																							
20	Transmission Line Project	281 days?																					
21	Preliminary Engineering	6 wks				1/5																	

All additional cost for work not identified in this study is the sole responsibility of the Requester unless other arrangements have been made.

⁹ The cost values are 2005 dollars with an accuracy level of ±20%.

Appendix A

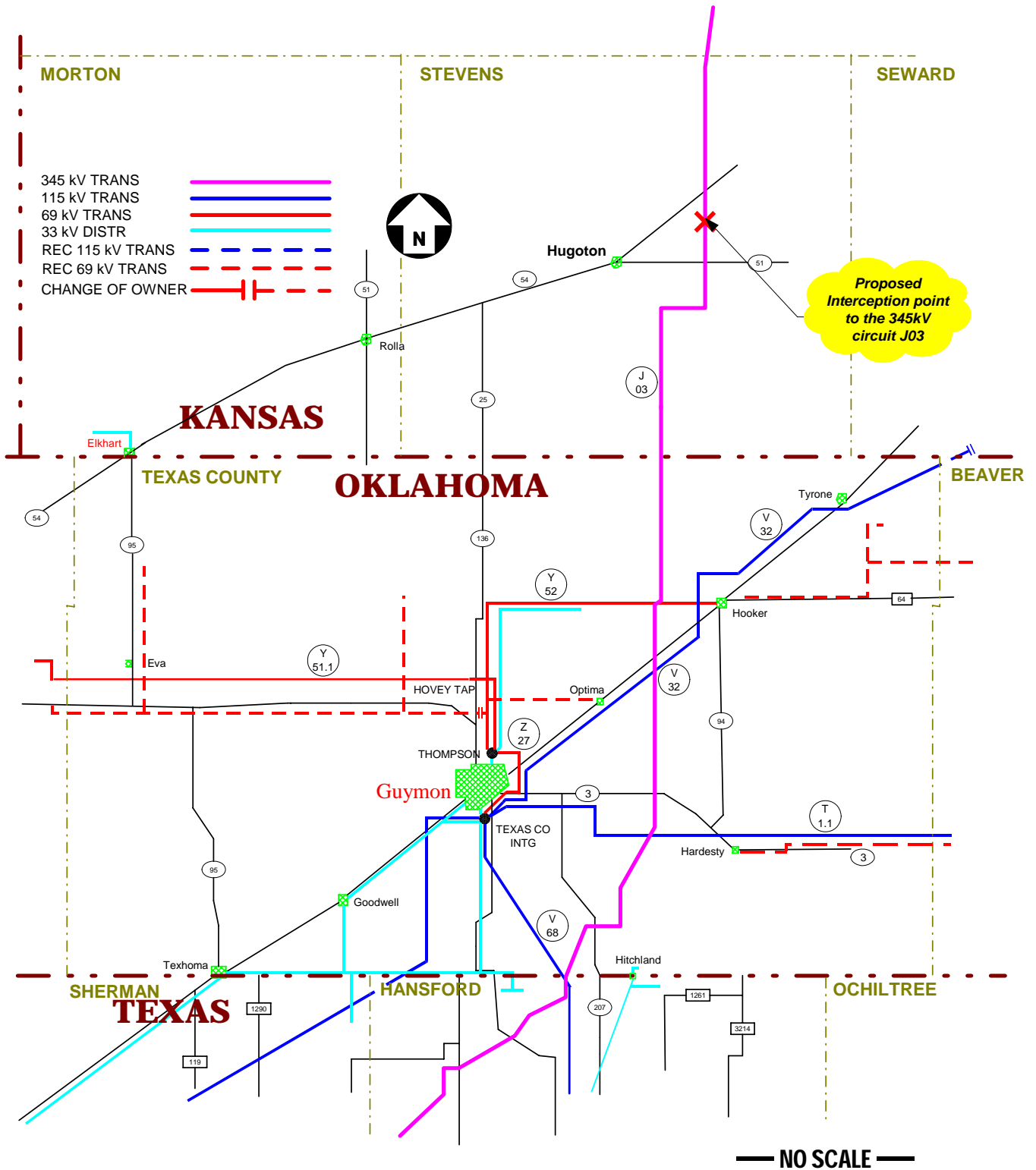
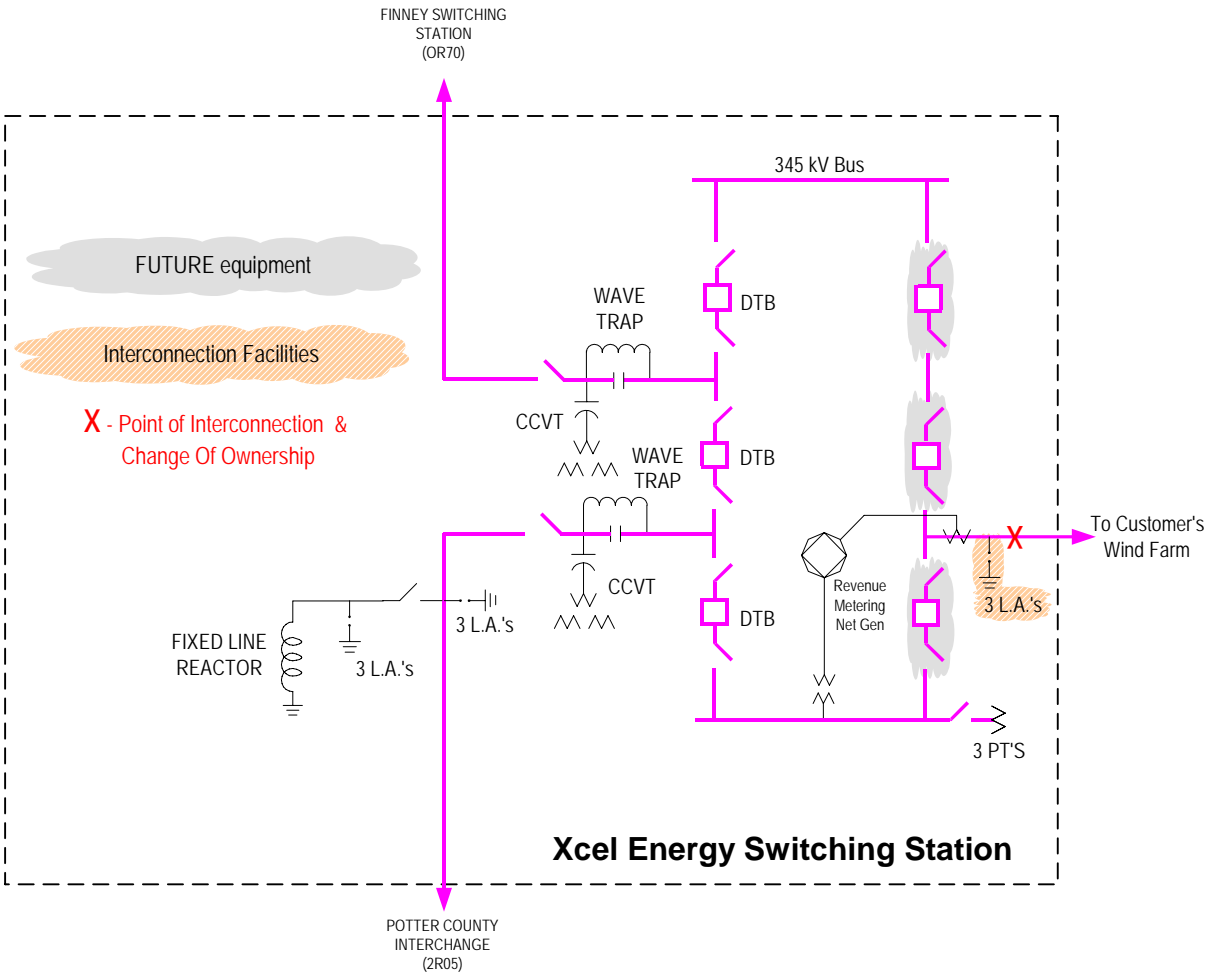

Figure A - 1 Proposed Interception Point to the Xcel Energy 345 kV Circuit J03



SYMBOL KEY					
	DTB, Dead Tank Breaker		Disconnect Switch		Lightning Arresters
	Current Transformer		Potential Transformer		

Figure A - 2 Switching Station One-line Diagram

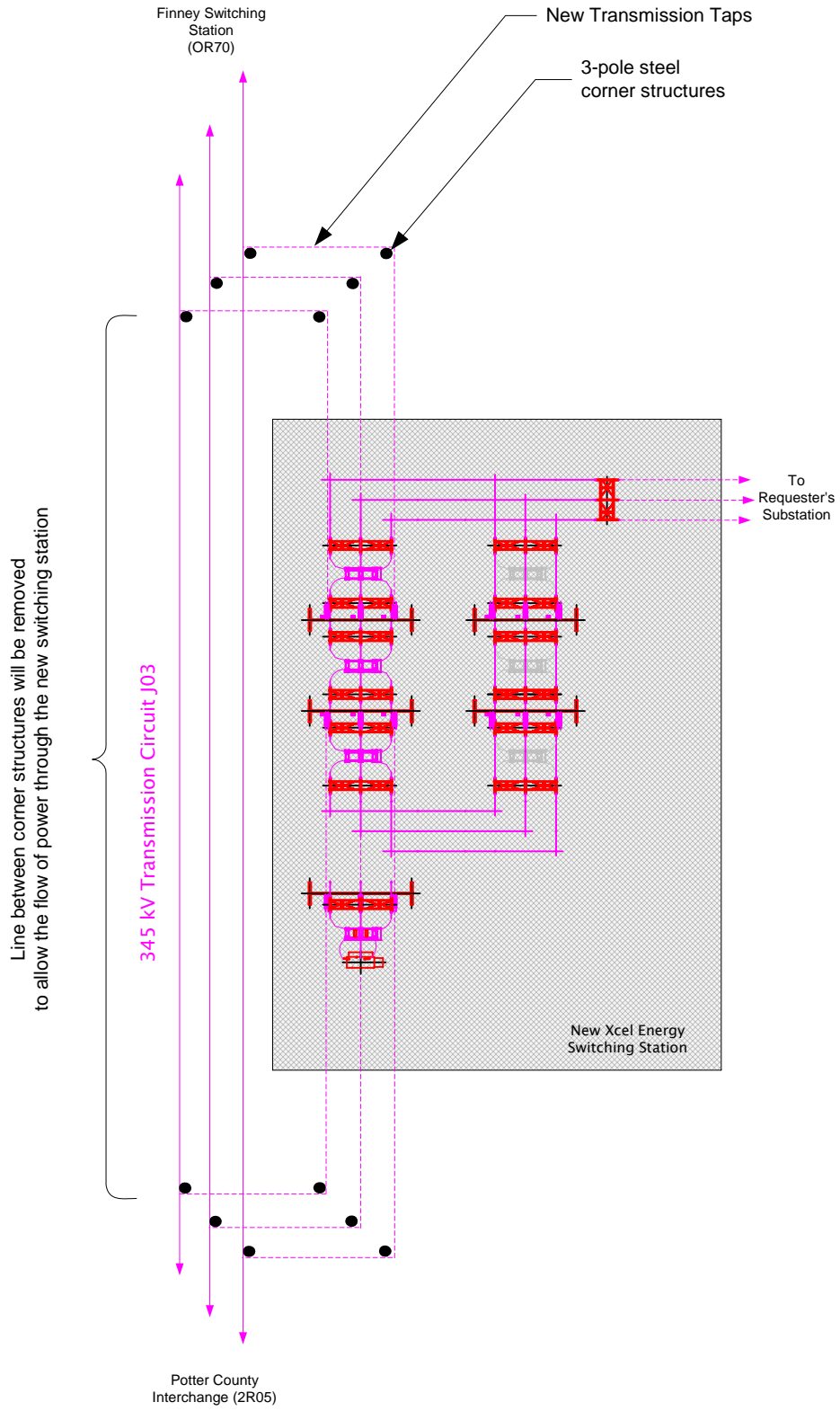

Figure A - 3 Proposed Line Taps on J03

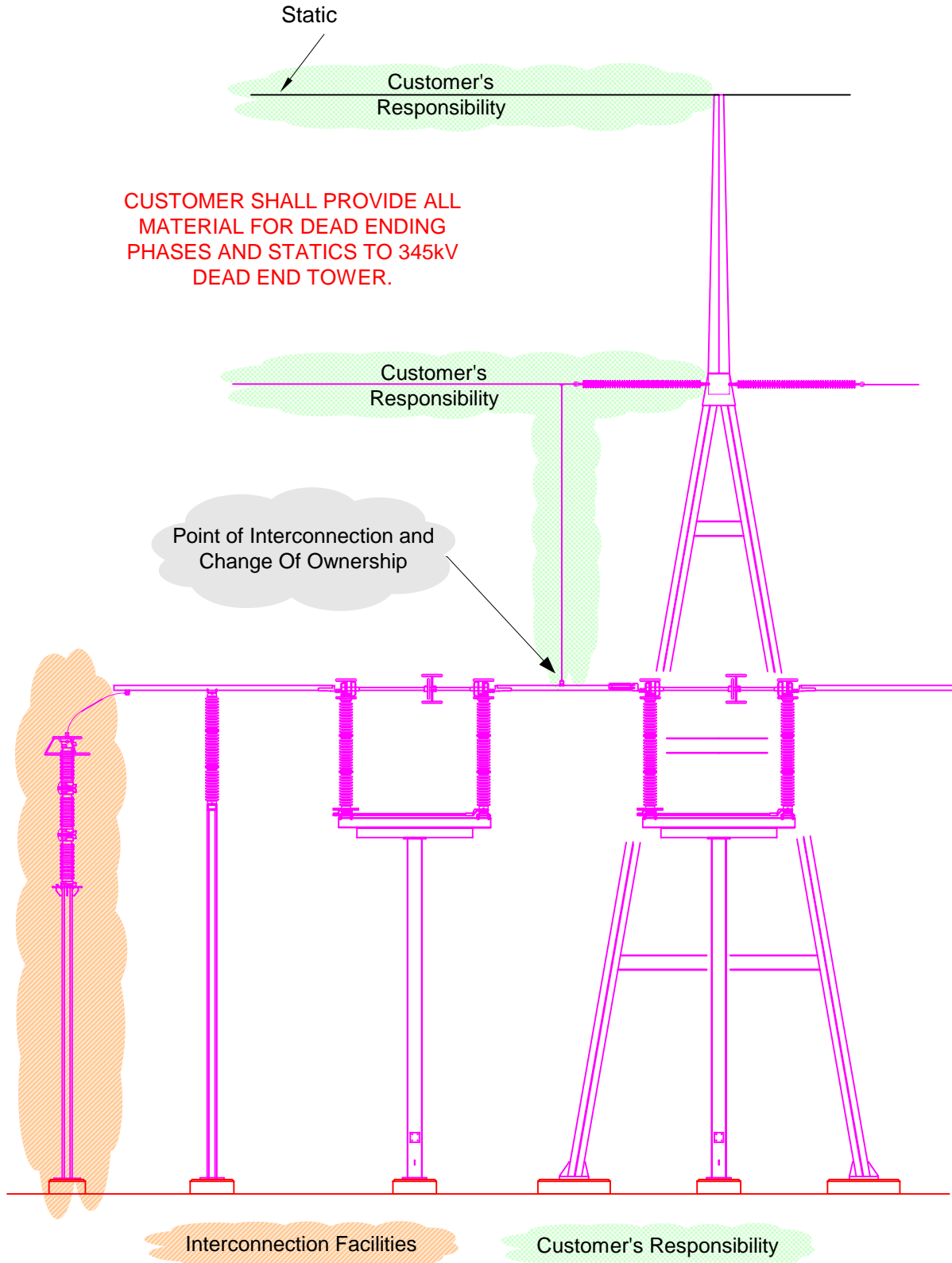

Figure A - 4 Point of Interconnection & Change of Ownership

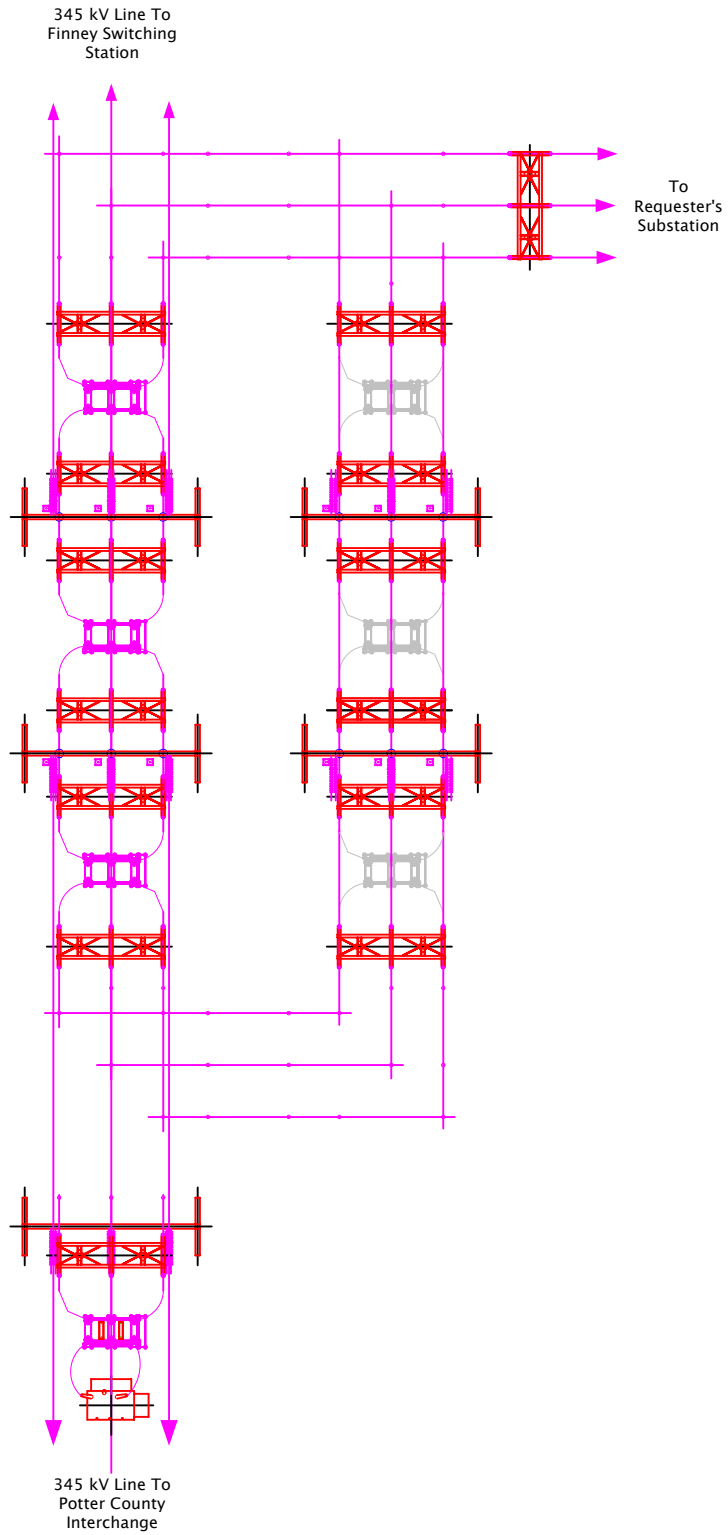
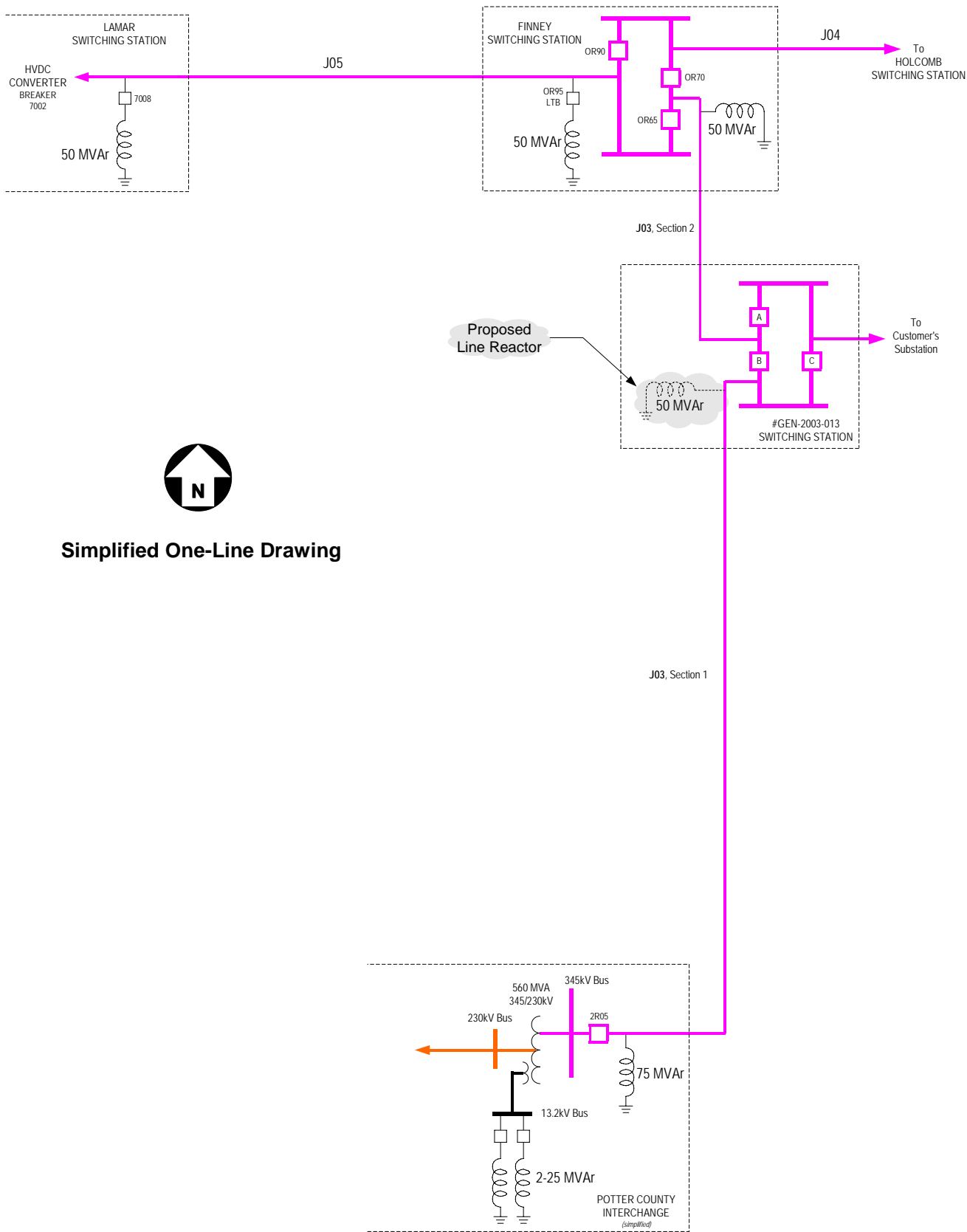
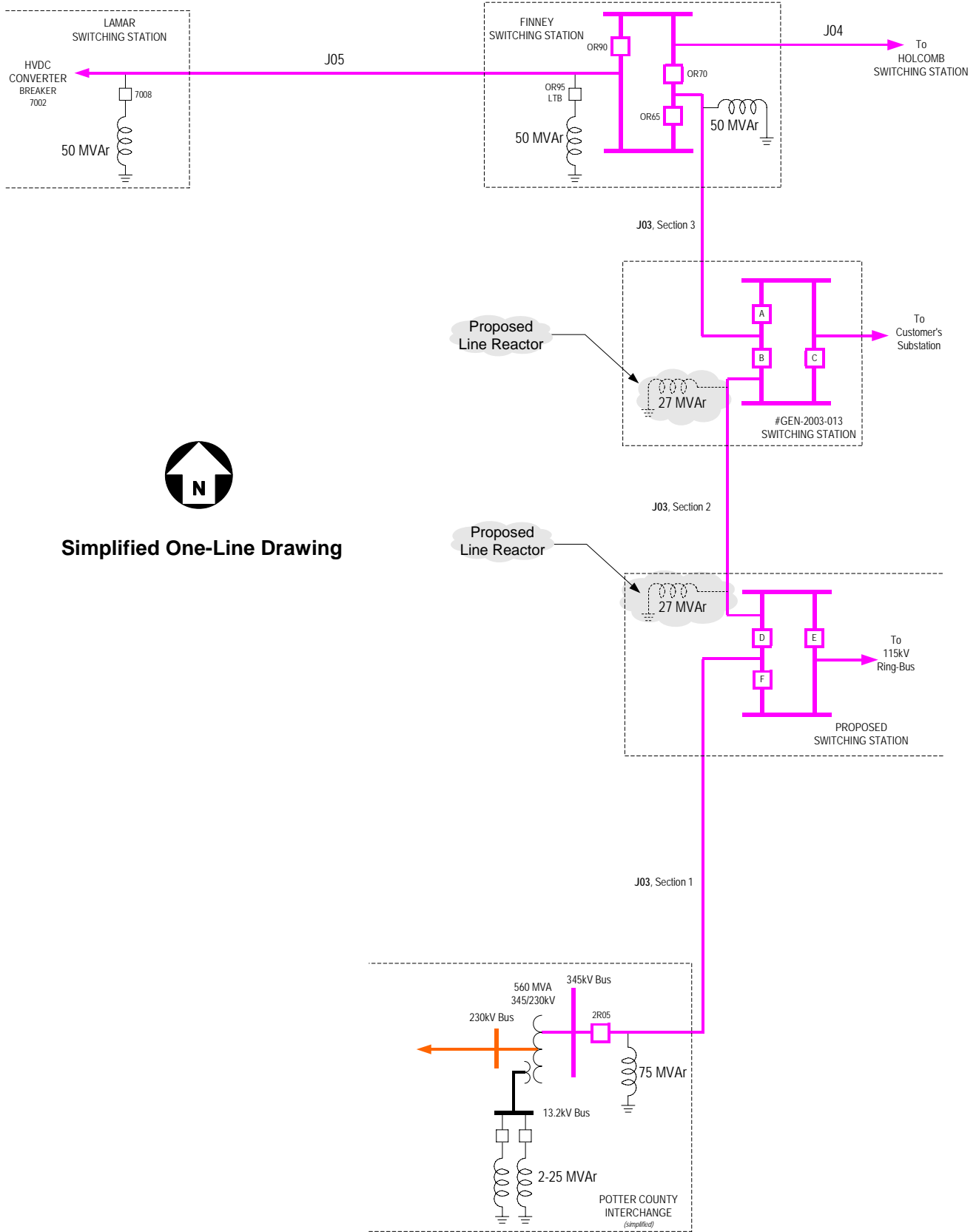

Figure A - 5 Switching Station Plan View



Simplified One-Line Drawing

Figure A - 6 Reactor For #GEN-2003-013



Simplified One-Line Drawing

Figure A - 7 Reactors with #GEN-2003-013 and Higher Queued Request