



***Feasibility Study for Generation
Interconnection Request***

GEN-2003-021

***SPP Tariff Studies
(#GEN-2003-021)***

March 2004

Executive Summary

<OMITTED TEXT> (Customer) has requested a feasibility study for the purpose of interconnecting up to 400MW of wind generation in Potter County, Texas within the service territory of Southwestern Public Service Company (SWPS). The proposed point of interconnection is on the Nichols to Hutchinson 230kV circuit K6 approximately 7.5 miles from Nichols. The proposed in-service date is December 2005. This request has essentially two options; first is 240MW connected on circuit K6 with 160MW connected per a previous request (GEN-2003-020) at Carson County substation and second is all 400MW connected on circuit K6 with no wind farm interconnected at Carson County substation.

Power flow analysis has indicated that for the powerflow cases studied, it is possible to interconnect up to 400 MW either with the entire 400MW at a new substation on circuit K6 or split with 240MW on circuit K6 and 160MW at Carson County. The 160MW at Carson County can only be interconnected with a special protection scheme to trip a portion of the wind farm at Carson County to reduce it's output such that the flow on the Carson Co. to Hutchinson line is 99MVA or less. This special protection scheme is detailed in study GEN-2003-020.

The proposed requirements for interconnection consist of constructing a new interconnection substation on circuit K6 at the point of interconnection. At this time, the substation is anticipated to be of a ring bus configuration, however, the final substation design and layout will be determined later in the Facilities Study if the customer elects to proceed.

If the customer's substation facility will be built close to the new switch station (less than one mile), a Certificate of Convenience and Necessity from the Public Utility Commission of Texas will not be required.

The total cost for this 230kV interconnection facility is estimated at \$3.39 million dollars, which is based on estimates provided by the Southwestern Public Service Company engineering department. The cost includes building 230kV from the customer substation facility into the new switch station, which was estimated at 1/2 mile (this could vary once the customers substation is located) and the cost to construct the switch station including all breakers and metering equipment. In order to interconnect 240MW on circuit K6 and 160MW at Carson County, the total cost would be near \$6.6 million dollars to construct both interconnection substations. This cost also does not take into account any special telemetering equipment required to facilitate the special protection scheme mentioned earlier.

This feasibility study takes into account static system reinforcements triggered by other generation projects that are positioned ahead in the queue. There have also been some higher queued requests removed from this study at the request of the customer. In the event that the assumption of particular generation projects and the system reinforcements triggered by these projects are different, this feasibility study may have to be revisited, potentially changing the requirements necessary for interconnecting this customer's 400 MW wind farm.

Introduction

<OMITTED TEXT> (Customer) has requested a feasibility study for the purpose of interconnecting up to 400MW of wind generation in Potter County, Texas within the service territory of Southwestern Public Service Company (SWPS). The proposed point of interconnection is on the Nichols to Hutchinson 230kV circuit K6 approximately 7.5 miles from Nichols. The proposed in-service date is December 2005. This request has essentially two options; first is 240MW connected on circuit K6 with 160MW connected per a previous request (GEN-2003-020) at Carson County substation and second is all 400MW connected on circuit K6 with no wind farm interconnected at Carson County substation.

Interconnection Facilities

The primary objective of this study is to identify the system problems associated with connecting the plant to the area transmission system and estimated costs of system modifications needed to alleviate the system problems.

The Feasibility and other subsequent Interconnection Studies are designed to identify attachment facilities and other direct assignment facilities needed to accept power into the grid at the interconnection receipt point.

The proposed requirements for interconnection consist of constructing a new interconnection substation on circuit K6 at the point of interconnection. At this time, the substation is anticipated to be of a ring bus configuration, however, the final substation design and layout will be determined later in the Facilities Study if the customer elects to proceed.

Currently, the Carson County substation is a simple tap on circuit V60. The new bus substation would route circuit V60 into and then out of the substation. A separate breaker terminal would be added to the new bus to accommodate the wind farm. One terminal of the new substation would lead to Hutchinson County Interchange to the north, another terminal would lead to the Pantex North substation, and the third terminal would lead to the customer facility. If the customer's substation facility will be built close to the new switch station (less than one mile), a Certificate of Convenience and Necessity from the Public Utility Commission of Texas will not be required.

The total cost for this 230kV interconnection facility is estimated at \$3.39 million dollars, which is based on estimates provided by the Southwestern Public Service Company engineering department. The cost includes building 230kV from the customer substation facility into the new switch station, which was estimated at 1/2 mile (this could vary once the customer's substation is located) and the cost to construct the switch station including all breakers and metering equipment. It also includes the cost of building 1/2 mile of 230 kV transmission line from the new substation to the wind farm collection substation, and right-of-way. This cost does not include any reactive support costs. Dynamic Stability studies will provide guidance as to whether any reactive compensation is necessary and whether it can be static or must be dynamic (such as a SVC).

The costs of interconnecting the facility to the SWPS transmission system are listed in Table 1.

These costs do not include any cost that might be associated with short circuit study results or dynamic stability study results. These costs will be determined when and if a System Impact Study is conducted.

Table 1: Interconnection Facilities

Facility	ESTIMATED COST (2003 DOLLARS)
Construct a new 3-breaker ring bus switch station on circuit K6	\$2,976,176
½ mile of 230kV line to the customer's wind farm	\$380,000
Right-of-Way	\$35,000
Total	\$3,391,176

Powerflow Analysis

A powerflow analysis was conducted for the facility using modified versions of the 2004 series SPP Planning models. The in-service date of the facility is proposed to be December 2005. The models used in this study were: 2005 Winter Peak, 2007 Summer Peak, 2007 Winter Peak, 2010 Summer Peak, and a 2010 Winter Peak. This is the end of the current SPP planning horizon. The output of the Customer's facility was offset in each model by a reduction in output of existing online SWPS generation.

Option 1: 240MW on circuit K6 and 160MW at Carson Co. (GEN-2003-020)

Power flow analysis has indicated that for the powerflow cases studied, it is possible to interconnect up to 240 MW on circuit K6 with no transmission system improvements. The Nichols 115/230kV transformer overloaded in certain situations due to the amount of online generation at Nichols. Per instruction from SPS, increasing the amount of generation at Nichols removed the overload in all cases. The 160MW wind farm interconnected at Carson County can be interconnected only with a special protection scheme to trip a portion of the wind farm to reduce it's output such that the flow on the Carson Co. to Hutchinson line is 99MVA or less. Details of this special protection scheme are detailed in study GEN-2003-020.

Option 2: 400MW on circuit K6 and 0MW at Carson Co.

Power flow analysis has indicated that for the powerflow cases studied, it is possible to interconnect up to 400MW on circuit K6 with no transmission system improvements. The Nichols 115/230kV transformer overloaded in certain situations due to the amount of online generation at Nichols. Per instruction from SPS, increasing the amount of generation at Nichols removed the overload in all cases.

Powerflow Analysis Methodology

The Southwest Power Pool (SPP) criteria states that: The transmission system of the SPP region shall be planned and constructed so that the contingencies as set forth in the Criteria will meet the applicable *NERC Planning Standards* for System Adequacy and Security –

Transmission System Table I hereafter referred to as NERC Table I) and its applicable standards and measurements.

Using the created models and the ACCC function of PSS/E, single contingencies in the SWPS control area were applied and the resulting scenarios analyzed. This satisfies the 'more probable' contingency testing criteria mandated by NERC and the SPP criteria.

There are several other proposed wind generation additions in the general area of the Customer's facility. It was assumed in the analysis that not all of these other projects were in service. Those previously queued projects that have advanced to nearly complete phases were included in this feasibility study. Significant differences in the assumptions used in this feasibility study may require that this study be revisited to determine this customer's impacts on the SPS transmission system.

Conclusion

The analysis of the customer's project shows that the proposed location can handle the entire 400MW of output under steady state conditions without system upgrades in all seasons out to the end of SPP's planning horizon. The 400MW can be interconnected entirely at the new 230kV switch station on circuit K6 or split with 240MW on circuit K6 and 160MW at Carson County with a special protection scheme.

The minimum cost of interconnecting the Customer project is estimated at \$3.39 million dollars. However, as stated earlier, previously queued projects were assumed to not be in service in this feasibility study. If any of those projects are constructed or the assumptions used in creating the study scenarios are significantly different, then this feasibility study may have to be revisited to determine the impacts of this customer's project on other SWPS transmission facilities.

These interconnection costs do not include any cost that may be associated with short circuit or transient stability analysis. These studies will be performed if the Customer signs a system impact study agreement.

The costs do not include any costs associated with the deliverability of the energy to final customers. These costs are determined by separate studies if the Customer requests transmission service through Southwest Power Pool's OASIS.

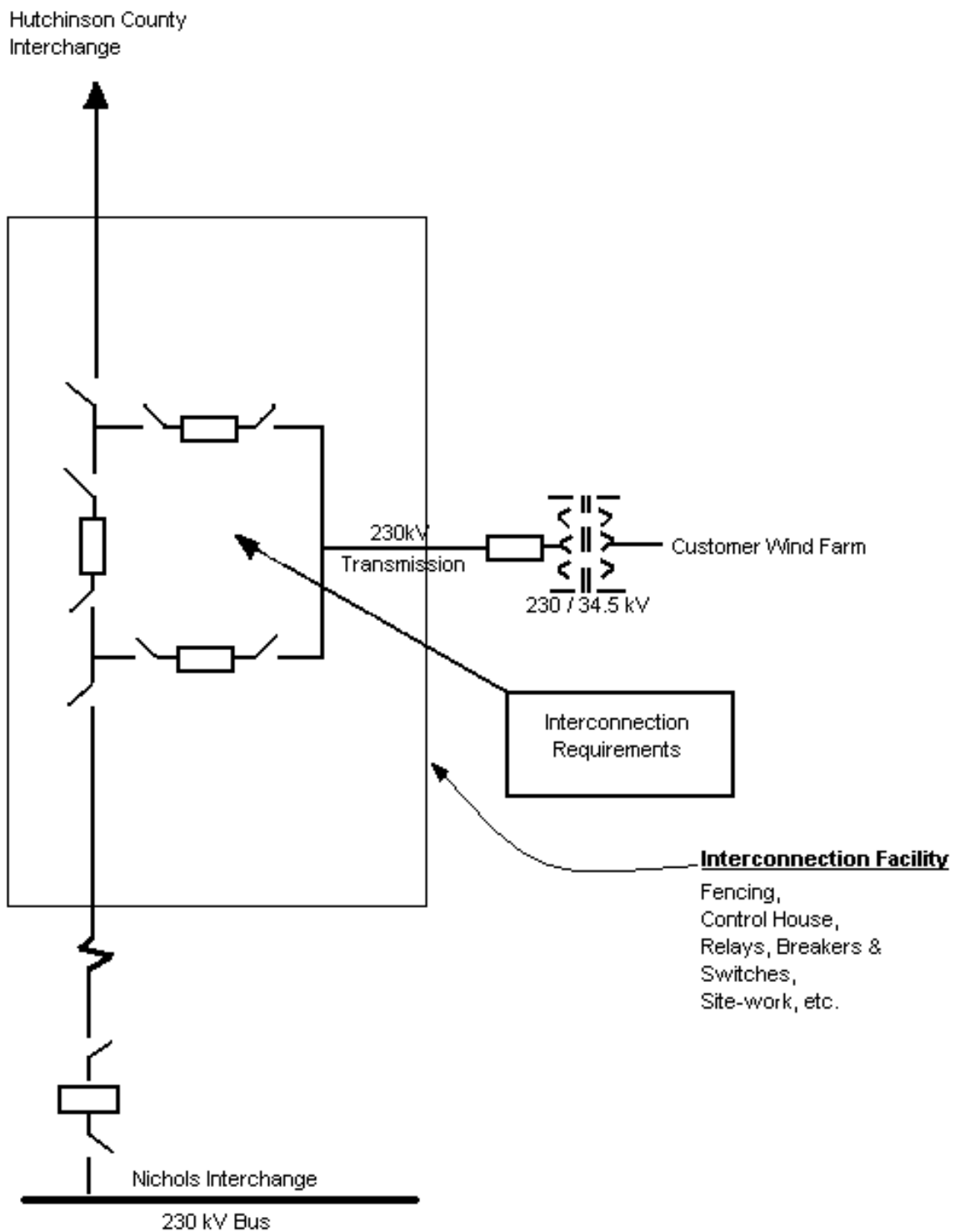

Figure 1. One-line Diagram of the 230 kV Interconnection

(Final substation design to be determined)

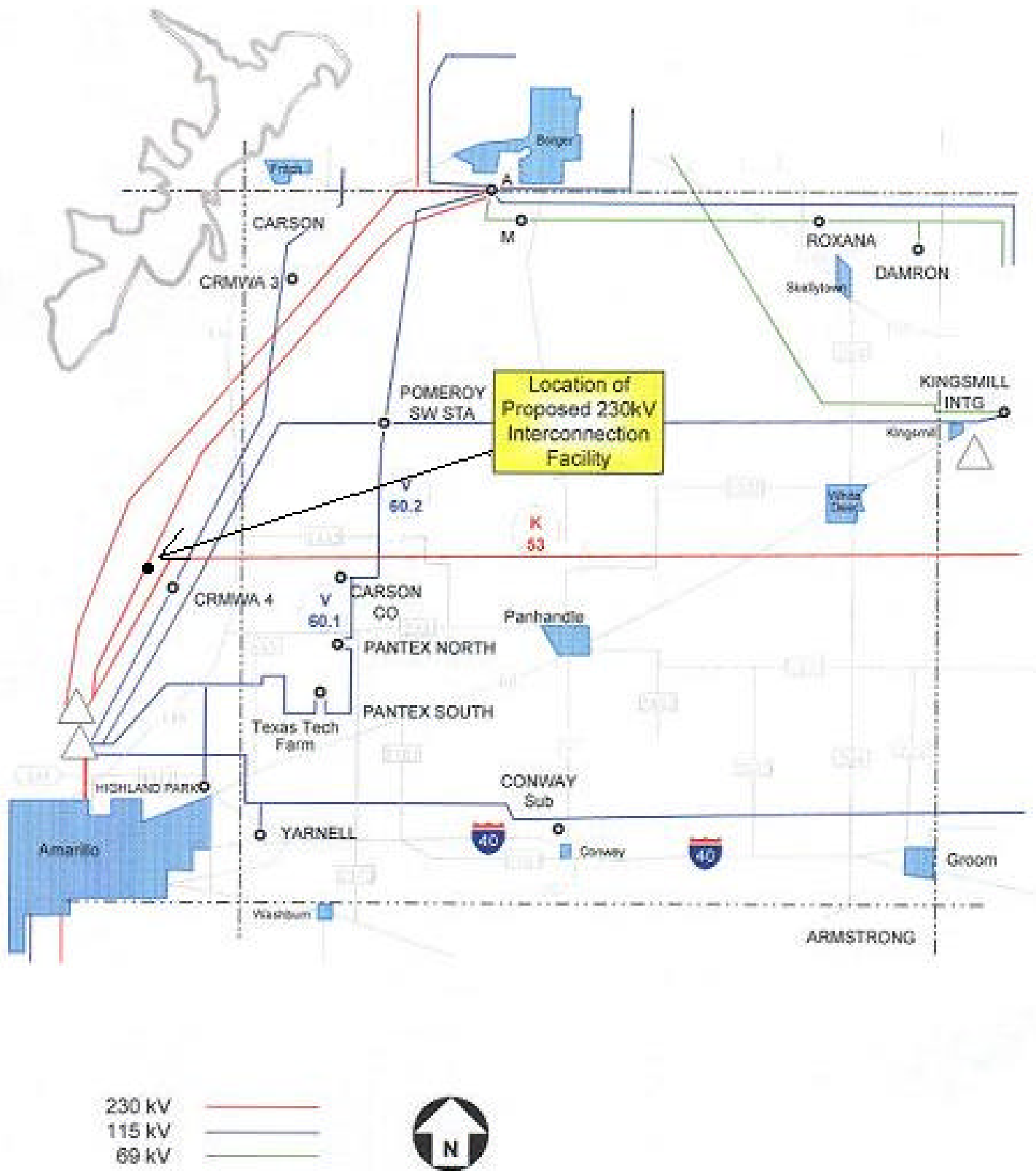

Figure 2: Map of the surrounding area