



**SPP**

*Southwest  
Power Pool*

***Facility Study for Generation  
Interconnection Request  
GEN – 2003 – 020***

***SPP Coordinated Planning  
(#GEN-2003-020)***

**May 2005**

## **Summary**

Xcel Energy performed the following study at the request of the Southwest Power Pool (SPP) for SPP Generation Interconnection request Gen-2003-020. The request for interconnection was placed with SPP in accordance SPP's Open Access Transmission Tariff Attachment V, which covers new generation interconnections on SPP's transmission system.

Pursuant to the tariff, Xcel Energy was asked to perform a detailed Facility analysis of the generation interconnection requests to satisfy the Facility Study Agreement executed by the requesting customer and SPP.



**Facilities Study  
For  
GEN-2003-020**

160 MW Wind-Generated Energy Facility  
Carson County, Texas  
SPP #GEN-2003-020

May 2005

Xcel Energy Services, Inc.  
Transmission Planning

## Executive Summary

<Omitted Text> (the “Requester” or “Interconnection Customer”) has requested the interconnection of a wind energy facility to the Southwestern Public Service Company (SPS) (d/b/a Xcel Energy, Inc) 115kV transmission system in the vicinity of Carson County Substation. This facility will interconnect to a new 115kV switching station located 1.2 miles east of Carson County Substation, which is located approximately 9 miles west of Panhandle, TX. The Southwest Power Pool (SPP) evaluated the request to interconnect this wind energy facility to the SPS transmission system in a System Impact Study completed in December 2004. This interconnection request was studied using 106 1.5MW GE wind turbine generators and was modeled as two single equivalent generators, 79.5 MW each. The proposed in-service date for the project is 2006.

The Requester requested the location of the interconnection to be in the vicinity of Carson County Substation, which will be 1.2 miles east of Carson County Substation. The new 115 kV Switching Station will be breaker and one-half configuration to facilitate the interconnection of the wind farm. Approximately 20 miles of 115 kV line from Hutchinson County Interchange to the new Switching Station will be upgraded to 795 MCM, which will not require a Certificate of Convenience and Necessity (CCN). No CCN is required because additional right-of-way (ROW) width is not needed for the proposed single steel pole transmission structures. A concern during this project is the coordination with the Department of Energy’s Pantex facility, which would be without their 2<sup>nd</sup> source during part of the construction of the upgrade of the 115 kV line to 795 MCM to Hutchinson County Interchange.

The Requester will build, own and maintain the 115 kV line from the wind farm’s substation to the new 115 kV Switching Station. Any reactive support added at the wind energy facility as outlined in the System Impact Study, shall be added such that the instantaneous voltage rise during switching is limited at the switching station as per SPS transmission switching guidelines.

Xcel Energy will require the Interconnection Customer to construct the Interconnection Facilities in compliance with the latest revision of the Xcel Energy Interconnection Guidelines for Transmission Interconnection Producer-Owned Generation Greater than 20 MW. This document describes the requirements for connecting new generation to the Xcel Energy operating company transmission systems including technical, protection, commissioning, operation, and maintenance. Xcel Energy will also require that the Interconnection Customer be in compliance with all applicable criteria, guidelines, standards, requirements, regulations, and procedures issues by the North American Electric Reliability Council, (NERC), Southwest Power Pool (SPP), and Federal Energy Regulatory Commission (FERC) or their successor organizations.

The Requester is responsible for the cost of the Requester’s Interconnection Facilities and any Direct Assigned Interconnection Facilities; inclusive of all construction required for the 115 kV transmission line from the Requester’s substation to the Switching Station.

It is anticipated that the construction of the new switching station, for the acceptance of wind generated electric energy from the Requester’s Wind Farm, will require approximately 16 months for completion if a CCN is not required. The cost of these upgrades, inclusive of the

Requester's cost for the Interconnection Facilities required for the interconnection of this new wind energy generation facility, is shown below:

Network Upgrade:	<b>\$ 6,154,670</b>
Direct Assigned <sup>1</sup> :	<b>\$ 874,028</b>
Interconnection Facilities <sup>1</sup> :	<b>\$ 76,903</b>
<hr/>	
Total:	<b>\$ 7,105,601</b>
<hr/>	

A detailed description of all costs associated with the construction of this new SPS switching station is shown in Table 2.

---

<sup>1</sup> Direct Assigned Cost To Requester

## Discussion

The new switching station required to connect the requestor's wind-generated energy facility will be located adjacent to the existing 115 kV transmission line from Hutchinson County Interchange, Pantex North and the tap to Carson County Substation intersect. The new switching station will consist of a six breaker 115 kV bus design for breaker and a half configuration. The existing transmission line will be routed in and out of the new switching station with 115 kV breakers on both lines towards Hutchinson County Interchange and Pantex North, on the new customer owned 115 kV transmission line and on the 115 kV line to Carson County Substation.

### General Description of Modifications and New SPS Facilities

1. **Construction of New Switching Station:** See Figure A - 2 in Appendix A for one-line diagram and Figure A - 3 for a plan view of the station.
  - 1.1. **Location:** The new 115 kV Switching Station is located approximately 9 miles west of Panhandle, Texas located in the northwest corner of Section 55 Block T of the H&W Survey of Carson County, Texas. See Figure A – 1 for a map of the local transmission system.
  - 1.2. **Bus Design:**
    - 1.2.1. The new 115 kV Switching Station will be built to accommodate the output from the wind energy facility. The new bus design will be a 2-string breaker and half with 4 terminals (six breakers). The four terminals will be for the tap to the Carson County Substation, for the wind farm connection from their substation, for tap to Pantex North and for tap to Hutchinson County Interchange. A seventh breaker will be connected to the main bus for two 14.4 MVAR capacitor banks. The new breaker design that is proposed is shown in Figure A – 2 in Appendix A.
  - 1.3. **Control House:** The control house will be utilized to house the new metering, protective relaying and control devices, terminal cabinets, and any fiber-optic cable terminations, etc for the new 115 kV Switching Station.
  - 1.4. **Line Reactors:** None.
  - 1.5. **Security Fence:** The switching station will have a 7-foot chain-link fence with steel posts set in concrete, with 1-foot of barbed wire on the top in a “V” configuration. The enclosed area will be approximately 340' × 240', with a rock yard surface.
  - 1.6. **Ground Grid:** A complete ground-grid will be installed per ANSI/IEEE STD 80-2000, with our standard 4/0 copper ground mesh on 40-foot centers with ground rods and 20-foot centers in corners and loop outside of fence.

- 1.7. **Site Grading:** Company contractor, per company specifications, will perform initial site grading and erosion control of the new switching station. Soil compaction shall be not less than 95% of laboratory density as determined by ASTM-D-698.
- 1.8. **Station Power:** A 66kV/120-240 volt transformer tapped off of the 115 kV bus will provide station power. A backup station power source will be taken from local distribution, if it is available, or a generator will be installed if no distribution service is available. Additionally, a flip-flop to automatically transfer the station power will be installed.
- 1.9. **Relay and Protection Scheme:** The new switching station to the Hutchinson County Interchange 115 kV line relaying will be directional comparison blocking (DCB) over power line carrier with a Pulsar TC10B. A SEL 321-1 (DCB) and a SEL 311-C (step distance) will be used. A SEL 279H-2 relay will be used for reclosing and a SEL 501-0 will be used for breaker failure.

The new switching station to Pantex North 115 kV line relaying will utilize the same type of equipment as that of the Hutchinson County Interchange 115 kV line.

The new switching station to the interconnection Requester owned line relaying will be step distance. A SEL 321-1 and a SEL 311-C will be used. A SEL 279H-2 relay will be installed; however there will not be any automatic reclosing. The SEL 279H-2 will be used for line/bus conditions and sync check along with supervisory closing of the breaker. A SEL 501-0 will be used for breaker failure.

Two sets of 115 kV PTs will be installed on the north and south buses with disconnect switches. There will be a provision made for an automatic throw-over of the PTs. A manual transfer switch will be available for maintenance purposes.

On both the Hutchinson and Pantex North lines there will be single CCVT's for line conditions. Line tuning units and wave traps will also be installed for the power line carrier communications.

Line arresters will be installed at each line termination on the dead-end towers.

- 1.10. **Revenue Metering:** On the 115 kV line to the Requester's substation, a billing meter will be installed along with an ION 8400 meter unit, ANSI C12.1 accuracy class 0.2 (3 PTs IEEE C57.13 accuracy class 0.3 and 3 CTs IEEE C57.13 accuracy class 0.15) for full 3 phase 4-wire metering. The metering unit will have 1000/600:1 PTs and 200/400:5 CTs. There will be two meters one will be primary and the other will be back-up, and each will have full 4 quadrant metering. Pulses out of the primary billing meter will be sent via SCADA to the Amarillo Control Center.
- 1.11. **Disturbance Monitoring Device:** Disturbance-monitoring equipment, capable of recoding faults, swings, and long term trending, will be installed to monitor and record conditions in the substation and on the transmission lines. This equipment will have communication capability with a dedicated communication circuit. The Disturbance equipment shall also be equipped with a GPS time syncing clock.

1.12. **Communications:** A high-speed phone circuit will be required between the new switching station and both Hutchinson County Interchange and Pantex North, which will provide communications for line relaying.

The RTU will be our standard large 5700 RTU with communications. An SEL 2020 will be installed for relay communications and other functions as required.

The Disturbance Monitoring Device will also have a dedicated phone circuit

Communications from the switching station to the Amarillo Control Center will consist of a 4-wire telephone data circuit provided by the Requester, if it is available. If it is not available, some type of communications will have to be installed, at the Requester's expense, to get the metering data to the Amarillo Control Center, along with the RTU information.

A station telephone will be installed in the control house. A telephone switch will be installed to transfer between the SEL-2020 and the billing meters along with the station talk service.

A schematic outlining the proposed communications is provided below:

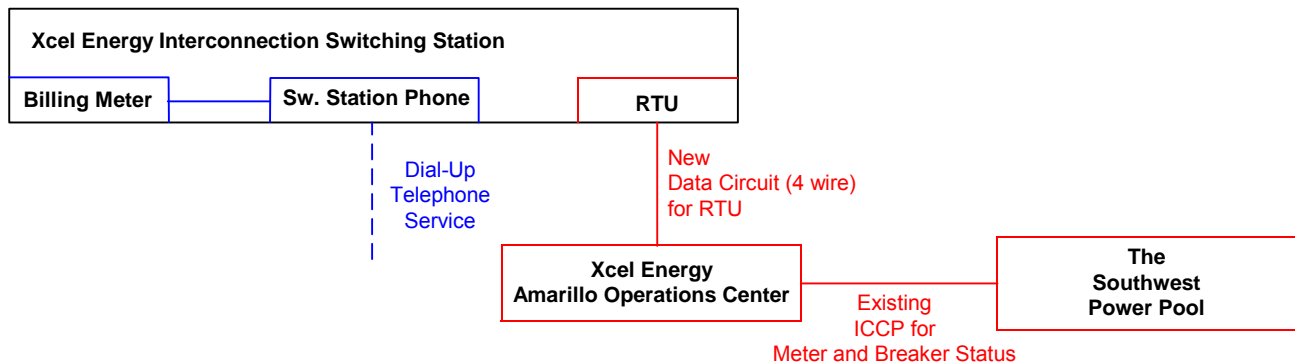

## 2. Transmission Line:

The Requester will construct, own, operate, and maintain the new customer owned 115 kV transmission line from the Requester's 115/34.5 kV substation to the new SPS Switching Station. Figure A-4 shows the Point of Interconnection and Change of Ownership. **The Xcel Energy transmission design group will require an engineering review of the Requester's transmission line design prior to any construction by the Requester or its contractor on the customer owned 115kV transmission line or doing work in close proximity to any SPS transmission line, will require an engineering review in a timely manner before construction of the 115 kV transmission line begins. If the review has not been made or the design at any of the aforementioned locations is deemed inadequate, the crossing(s) and or termination into the new switching station will be delayed until the matters are resolved. Xcel Energy will not be held responsible for these delays.**



- 2.1. **115 kV Termination Structure:** An existing Xcel Energy overhead 115 kV transmission line (V-60) will be tapped in and out of the new switching station centered on structure 235. This transmission line will become two overhead lines and the transmission termination structures will be constructed on the east and south sides of the switching station. The existing 115 kV line between Hutchinson and Pantex North will be re-terminated such that power flows in and out of the proposed switching station. The location of the Switching Station will be in the NW Corner of the Section 55; Block T of the H&W Survey Carson County, Texas, with the GPS coordinates of the structure being 35° 22' 57"N, 101° 32' 29"W, which is adjacent to the north side and the west side of Section 55.

Another overhead 115 kV transmission termination structures will be constructed to the west side of the switching station to re-terminate an existing 115 kV transmission line, which serves Carson County Substation. The fourth 115 kV transmission line will be on the north side of the switching station. All circuits will be dead-ending on 115 kV terminals within the new switching station. See Figure A-2.

### 3. Right-Of-Way:

- 3.1. **New 115 kV Transmission Line Taps:** See Figure A-3 for location of line taps relative to switching station site.
  - 3.2. **Permitting:** Currently, permitting for the construction of the new switching station is not required in the State of Texas. The 115 kV transmission line to be upgraded to 795 MCM may require a CCN.
  - 3.3. **Switching Station Location:** The new switching station will be constructed adjacent to the existing 115 kV transmission circuit V-60, assuming the land can be procured from the landowner.
4. **Construction Power and Distribution Service:** Both Construction and Station power, in addition to any distribution service required for the Requester's wind-generated energy facility, are the sole responsibility of the Requester. **Xcel Energy, Inc. cannot provide station power (retail distribution service) for the Requester's substation if the location of the requester's substation lies outside of the Xcel Energy service area.**
  5. **Project and Operating Concerns:** Close work between the Transmission group, the Requester's Personnel and local operating groups will be imperative to have this project in service on the scheduled date.

## 6. Short Circuit Study Results:

The Short Circuit Analysis was performed internally by Xcel Energy Services to determine the available fault current at the 115 kV bus of the new switching station. These values may be used as a starting point for the determination of the available fault currents and interrupting capability of their facilities. The results are shown in Table 1, and the impedances are in per-unit at the specified voltage.

Fault Location	Fault Current (A)		Impedance (p.u $\Omega$ ) <sup>2</sup>	
	Line-to-Ground	3-Phase	Z <sup>+</sup>	Z <sup>0</sup>
New Switching Facility 115 kV Bus	4,251.88	6,567.74	0.01494 + j 0.07497	0.05203 + j 0.19471

## Estimated Construction Costs:

The projects required for the interconnection of the 160 MW wind energy generating facility consist of the projects summarized in the table below:

**Table 2, Required Interconnection Projects**

Project	Description	Estimated Cost
<b>Network Upgrade</b>		
1	115 kV breaker and one half	\$ 2,247,814
2	Control House	\$ 206,855
3	Right-of-Way Cost (station land, surveying, etc.)	\$ 32,000
4	Relay Modifications, Pantex North and Hutchinson County Interchange	\$ 195,940
5	115 kV Transmission Line Work and ROW	\$ 3,472,061
<b>Subtotal:</b>		<b>\$ 6,154,670</b>
<b>Interconnection Facilities (at the Requester's Expense)</b>		
6	Communications Cost	\$ 50,000
7	115 kV Arresters and Metering	\$ 26,903
<b>Subtotal:</b>		<b>\$ 76,903</b>
<b>Direct Assigned (at the Requester's Expense)</b>		
8	Capacitor Bank, 2-14.4 MVar	\$ 874,028
<b>Subtotal:</b>		<b>\$ 874,028</b>
<b>Total Cost:</b>		<b>\$ 7,105,601</b>

<sup>2</sup>Z<sup>+</sup> – Positive Sequence Impedance in p.u on a 100 MVA base

Z<sup>0</sup> – Zero Sequence Impedance in p.u on a 100 MVA base

## 7. Engineering and Construction Schedule:

It is anticipated that the switching station and all associated components will be constructed and ready to receive power from the Requester's wind farm approximately 16 months from the day an interconnection agreement is signed, unless prior arrangements have been made. This is the earliest Xcel Energy can complete the project as a result of other scheduling considerations. A construction schedule is shown below. If a CCN is required a minimum of 12 months should be added to the schedule shown below.

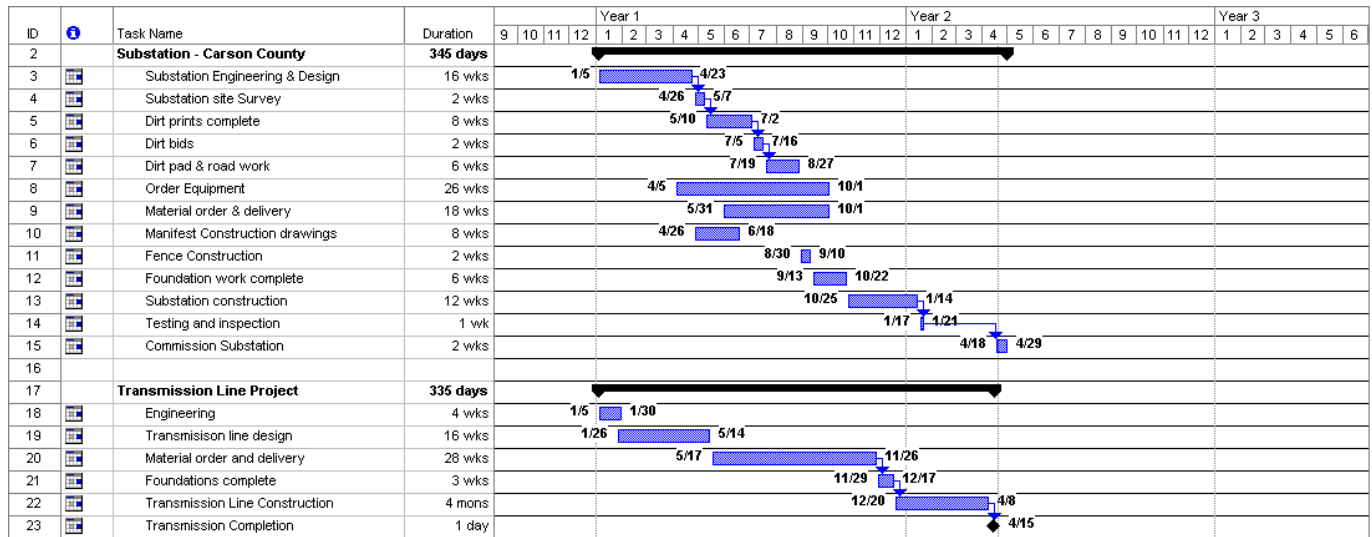

All additional cost for work not identified in this study is the sole responsibility of the Requester unless other arrangements are made.

## Appendix A



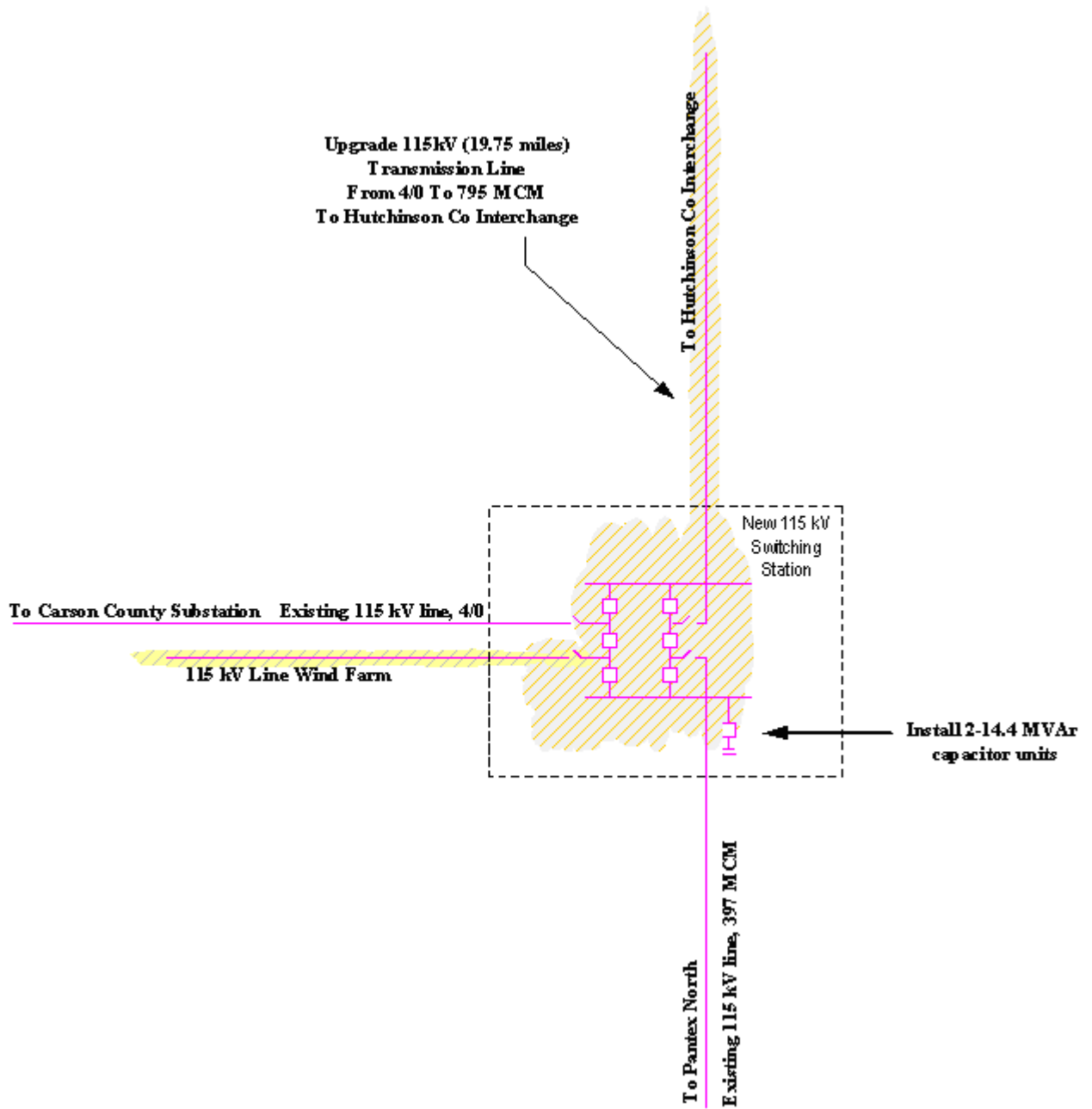

Figure A - 2. One-line diagram for <Omitted Text>, a new 115 kV Switching Station in Carson County.

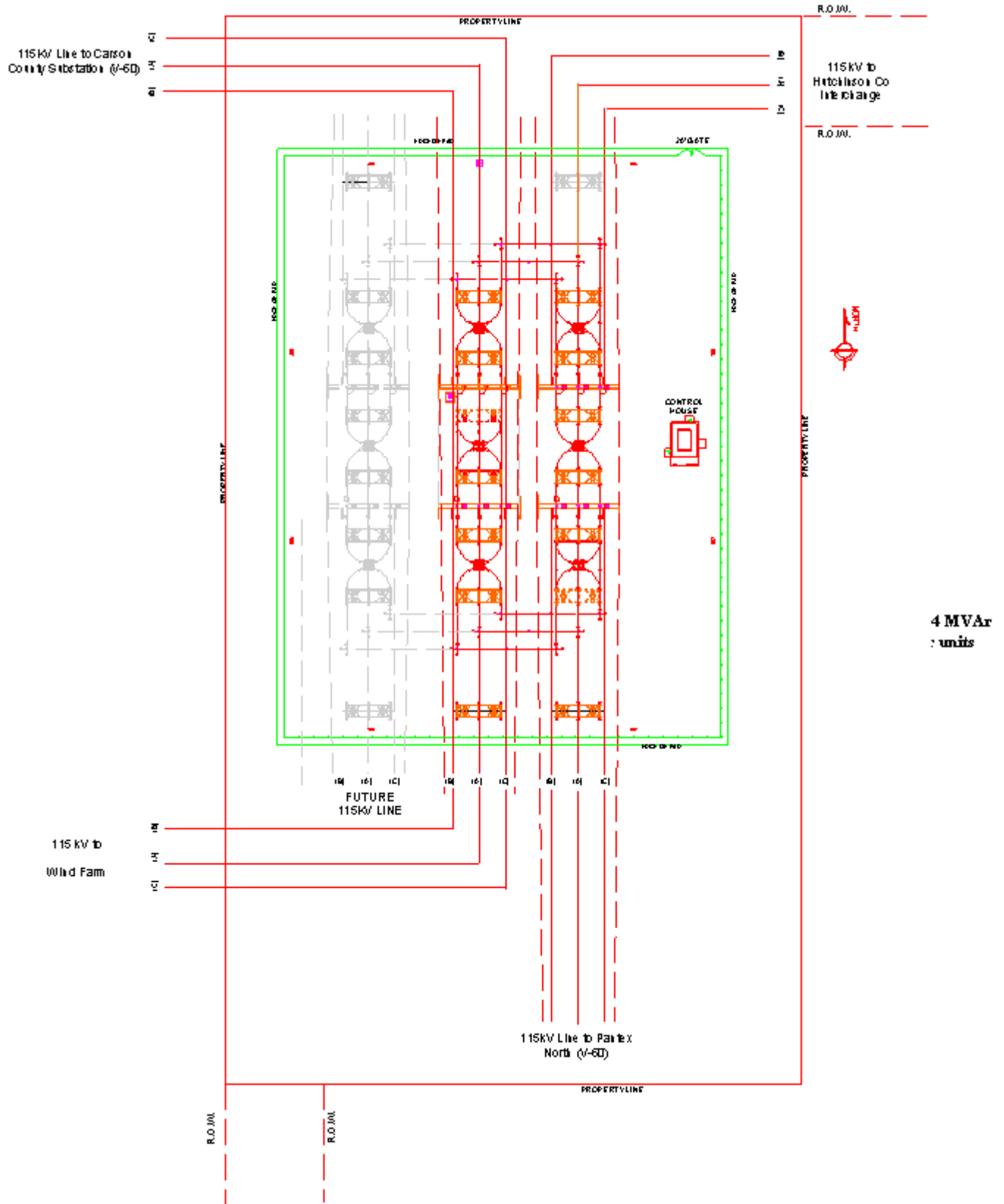
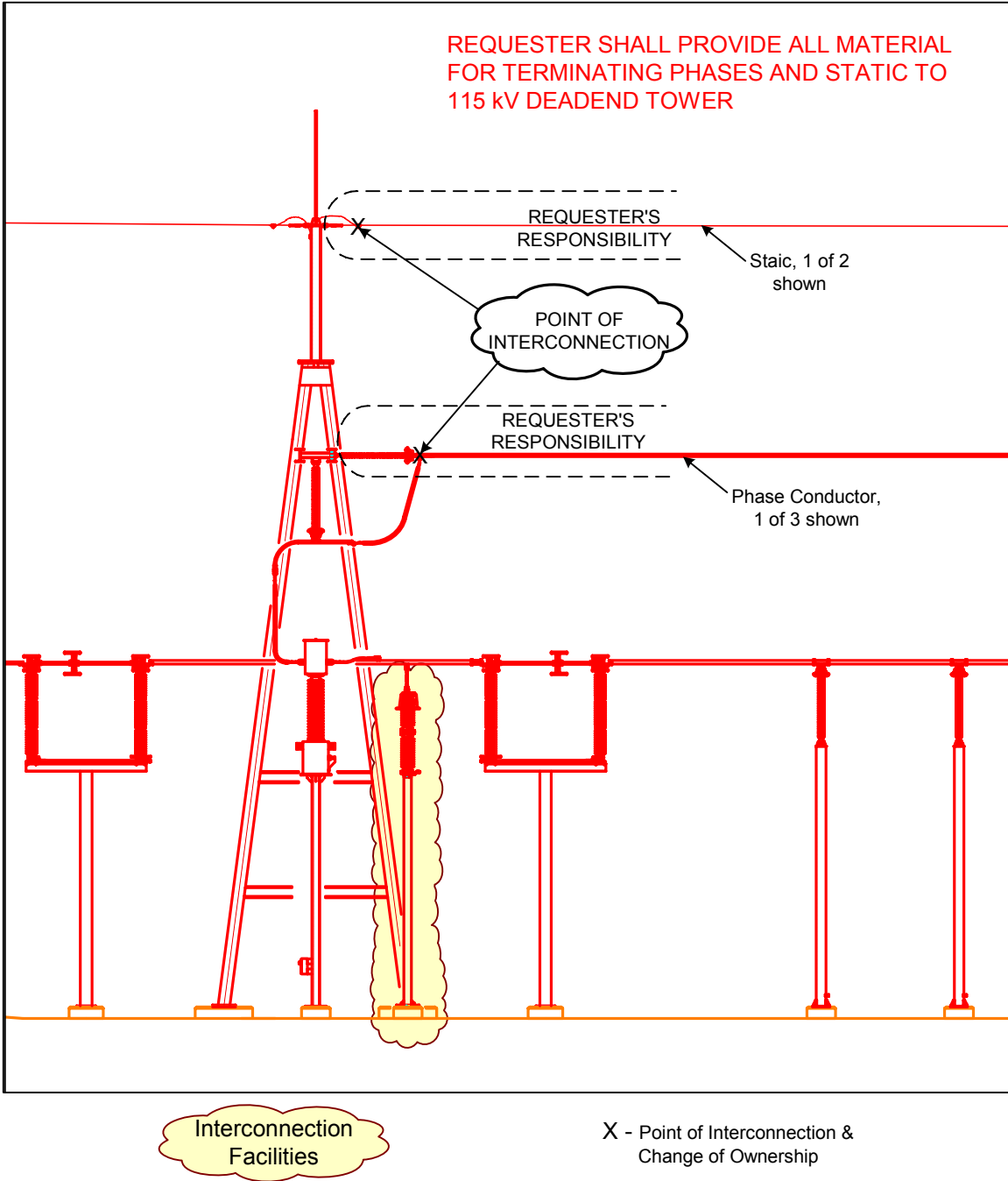

Figure A-3. Site Layout 115 kV Switching Station Carson Co.



**Figure A-4. Point of Interconnection & Change of Ownership**