



***Impact Study  
For  
Generation Interconnection  
Request  
GEN-2003-006A***

***SPP Tariff Studies***

***(#GEN-2003-006A)***

***September, 2007***

## **Summary**

Pursuant to the tariff and at the request of the Southwest Power Pool (SPP), Pterra Consulting Inc. (Pterra) performed the following Impact Study to satisfy the Impact Study Agreement executed by the requesting Customer and SPP for SPP Generation Interconnection request #GEN-2003-006A.

The purpose of this restudy is to evaluate the Customer's request to change turbines and use the Vestes V-90 3.0MW wind turbine for this generation interconnection request. This study addressed the stability and reactive compensation required for the Vestes wind turbines.

### Reactive Compensation Issues

The Impact Study determined that the Customer will be required to install at least two 34.5kV capacitor banks for the wind farm. The capacitor banks will be 18Mvar and 16Mvar.

The Impact Study determined that two STATCOM devices will be required on the 34.5kV buses of the Interconnection Customer's 230/34.5kV transformers. These devices are to have a short term rating (2 second) of 10MVA. A continuous rating of 4MVA will suffice. These devices are necessary for the wind farm to meet FERC Order #661A requirements for low voltage ride through.

The Large Generation Interconnection Agreement for this generation interconnection request will need to be revised to reflect the changes determined in this Impact restudy.

### Effect of Expansion Plan Projects

It is not known for sure if the SPP Expansion Plan project, Rhoades – Phillipsburgh 115kV transmission line will be in service in time for the operation of the GEN-2003-006A wind farm. The line was not included in the winter model for this request.

As a further sensitivity, SPP ran the problematic contingencies on the winter peak model with the Rhoades – Phillipsburgh 115kV transmission line in service. The wind farm was found to still require a STATCOM device to dampen the voltage and power oscillations that were observed.

However, it was found that if the Rhoades – Phillipsburgh 115kV transmission line is in service, that only one 34.5kV, 4MVA STATCOM device will be necessary. This STATCOM device should be located at the second 230/34.5kV substation of the wind farm.

*Pterra Consulting*

Report No. R127-07

# “Impact Study for Generation Interconnection Request GEN-2003-006A”

Submitted to

**The Southwest Power Pool**

August 2007



4 Automation Lane, Ste.250, Albany, NY 12205 Tel: 518-724-3832 Web: [www.pterra.us](http://www.pterra.us)

*Report No. R127-07*

# “Impact Study for Generation Interconnection Request GEN- 2003-006A”

<b>1. Executive Summary .....</b>	<b>4</b>
<b>2. Introduction .....</b>	<b>6</b>
2.1 Project Overview .....	6
2.2 Objective .....	7
<b>3. Stability Analysis .....</b>	<b>9</b>
3.1 Modeling of the Vestas V-90 3.0 MW Wind Turbine Generators .....	9
3.3 Assumptions .....	10
3.4 Faults Simulated .....	10
3.5 Simulation Results .....	12
<b>4. Conclusion .....</b>	<b>14</b>

## 1. Executive Summary

This report presents the stability simulation findings of the impact study of a proposed interconnection (Gen-2003-006A). The analysis was conducted through the Southwest Power Pool Tariff for a 230 kV interconnection for 201 MW wind farm in Cloud County, Kansas. This wind farm will be interconnected to a new station on the Concordia – E. Manhattan 230 kV transmission line owned Mid Kansas Electric Corporation (affiliate of Sunflower) formerly West Plains Electric. The customer has requested that Vestas V-90 3.0 MW wind turbine generator (WTG) should be studied.

Two base cases each comprising of a power flow and corresponding dynamics database for 2011 summer and 2007 winter were provided by SPP. Transient stability simulations were conducted with the proposed wind farm in service with a full output of 201 MW. In order to integrate the proposed 201 MW wind farm in SPP system, the existing generation in the SPP footprint was re-dispatched as provided by SPP.

Fourteen (14) faults were considered for the transient stability simulations which included 3-phase faults, as well as, 1-phase to ground faults, at the locations defined by SPP.

With Vestas V-90 3.0 MW WTG, the proposed 201 MW wind farm was modeled with under/over voltage/frequency ride through protection. The settings were in accordance with standard or default settings for the Advanced Grid Option (AGO) package. Unity power factor at the point of interconnection was achieved by placing 18 MVAR and 16 MVAR capacitor banks at the low voltage side of the 230/34.5 kV grid transformers. The taps of the two 230/34.5 kV transformers were set to 1.05 P.U.

The simulation results showed that:

- For summer peak and winter peak loading conditions, the proposed 201 MW wind farm tripped for one fault; fault # 8 (SLG fault at East Manhattan on 230 kV line to Cloud Tap with Breaker failure at Cloud Tap) out of the fourteen (14) faults simulated. However, the tripping of the wind farm for this fault is because the fault clearing procedures leave the wind farm residing in an isolated island. Additionally, for winter peak loading conditions, the wind farm tripped for fault #7 (3-phase fault at East Manhattan on 230 kV line to Cloud Tap) due to relay actuation on low voltage.
- For winter loading conditions, further analysis for those faults where there was no tripping of the proposed 201 MW wind farm showed that post-fault voltage did not recover fully and oscillatory voltage behavior was observed for faults # 5 and # 6 (3-phase fault at Cloud Tap on 230 kV line to East Manhattan, and SLG fault at Cloud Tap on 230 kV line to East Manhattan, Breaker failure at East Manhattan). This oscillatory voltage behavior was not observed for the same faults in the summer peak loading conditions.

- Consequently, dynamic voltage support is recommended comprising of two STATCOMs located at the low voltage side of the 230/34.5 kV grid transformers. It was found that a STATCOM with a short term rating (2 seconds) of approximately 10 MVAR and a continuous rating of 4 MVAR would be sufficient. The STATCOMs were set to float during normal conditions with MVAR outputs close to zero.
- For both summer and winter loading conditions, prior queued project GEN-2002-026, a 121 MW wind farm consisting of Vestas V80 WTGs on the McDowell – Morris County 230 kV line, tripped for faults # 7 and 11. The trippings were all due to relay actuation on low voltage. According to the scope of work, faults # 7 and 11 (3-phase fault at East Manhattan on 230 kV line to Cloud Tap, and 3-phase fault at E Manhattan on the line to JEC) were re-run with the Low Voltage Ride Through (LVRT) protection disabled. The results showed that all oscillations were well damped and no trippings were detected.

With this recommended two 4-MVAR STATCOMs, all oscillations are well damped. The study finds that the proposed 201 MW wind farm project shows stable performance with the aforementioned operating schemes and reinforcement of SPP system for the contingencies tested on the supplied base cases.

## 2. Introduction

### 2.1 Project Overview

The proposed 201 MW wind farm will be interconnected to a new substation on the Concordia to East Manhattan 230 kV line. Two new 230 kV lines will be built as shown in Figure 1. Figure 1 shows the interconnection diagram of the proposed GEN-2003-006A project to the 230 kV transmission network. The detailed connection diagram of the wind farm was provided by SPP.

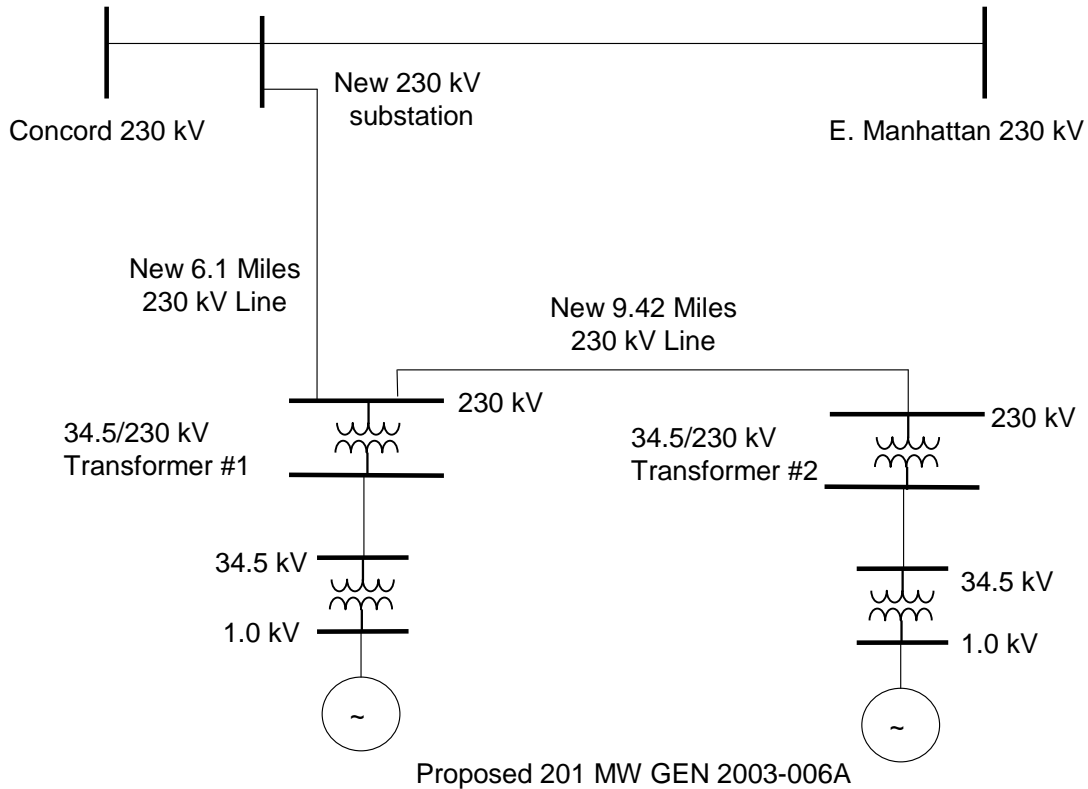

Figure 1 Interconnection Plan for GEN-2003-006A to the 230 kV System

Unity power factor at the point of interconnection was achieved by placing 18 MVAR and 16 MVAR capacitor banks at the low voltage side of the 230/34.5 kV grid transformers. The taps of the two 230/34.5 kV transformers were set to 1.05 P.U.

In order to integrate the proposed 201 MW wind farm in SPP system, the existing generation in the SPP footprint was re-dispatched as provided by SPP.

In order to simplify the model of the wind farm while capturing the effect of the different impedances of cables (due to change of the conductor size and length), the wind turbines connected to the same 34.5kV feeder end points were aggregated into one equivalent unit. An equivalent impedance of that feeder is represented by taking

the equivalent series impedances of the different feeders connecting the wind turbines. Using this approach, the proposed 201 MW wind farm was modeled with 33 equivalent units as shown in Figures 2. The number in each circle in the diagram shows the number of individual wind turbine units that were aggregated at that bus.

SPP provided the data for the following equipment:

1. The impedance values for 34.5 kV feeders.
2. WTG unit step up transformers.
3. 230 kV/34.5kV transformers.
4. The line parameters of the new 230 kV lines.

Prior queued project, Gen 2002-026 was already modeled in the provided power flow cases. The project is a 121 MW wind farm consisting of Vestas V80 WTGs connected to the McDowell – Morris County 230 kV line.

## **2.2 Objective**

The objective of the study is to determine the impact on system stability of connecting the proposed 201 MW wind farm to SPP's 230 kV transmission system.



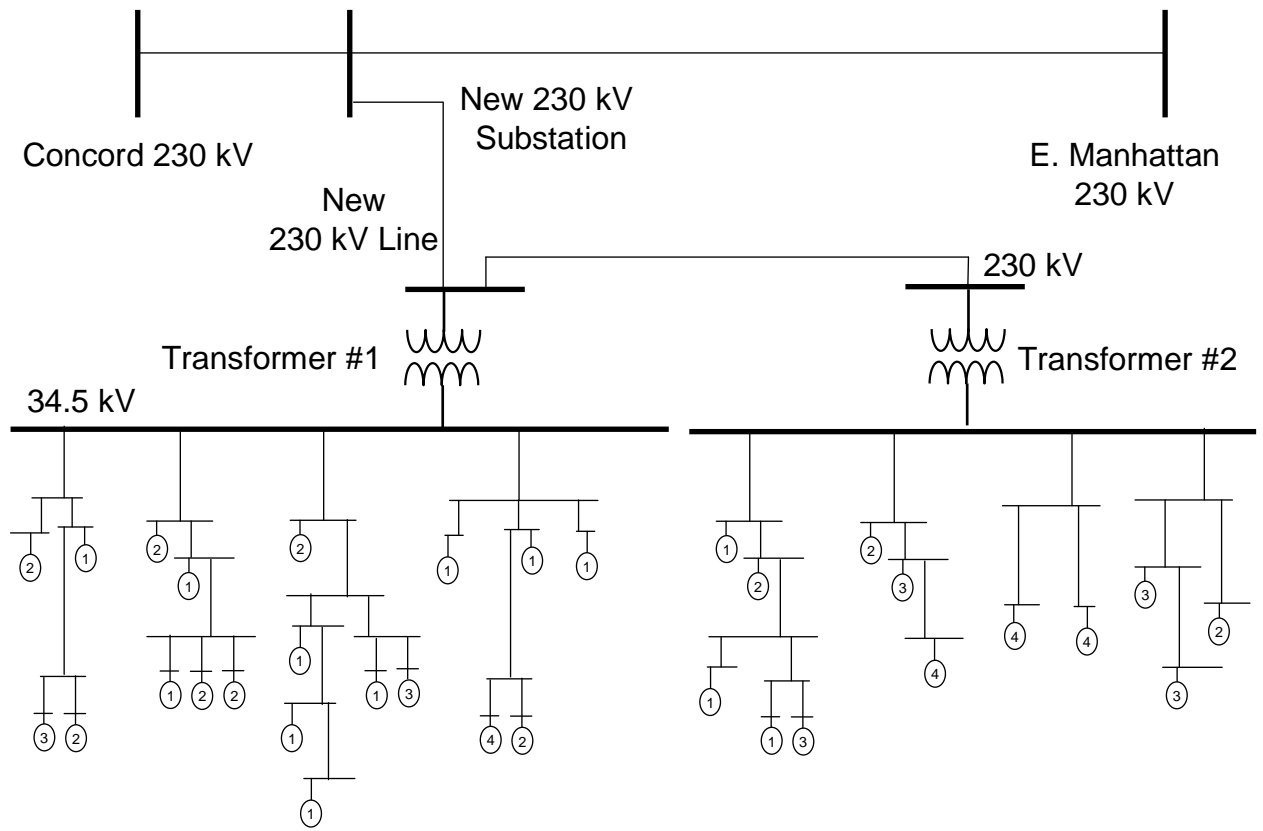

Figure 2 Wind Farm Equivalent Representation in Load Flow (Vestas V-90 3.0 MW WTG)

### 3. Stability Analysis

#### 3.1 Modeling of the Vestas V-90 3.0 MW Wind Turbine Generators

Equivalents for the wind turbine and generator step-up (GSU) transformer in the load flow case were modeled. For the stability simulations, the Vestas V-90 3.0 MW wind turbine generators were modeled using the latest wind turbine model set.

Table 1 Vestas V-90 3.0 MW Wind Generator Data

Parameter	Value
BASE (KV)	1.0
Rating (MVA)	3.0
TRANSFORMER MBASE (MVA)	3.16
TRANSFORMER R ON TRANSFORMER BASE	0.0065362
TRANSFORMER X ON TRANSFORMER BASE	0.0947749
GTAP	1.0
PMAX (MW)	3.0
PMIN	0.0
Power factor Range	0.98 (Lead) - 0.96 (Lag)
Speed (RPM)	1800
INERTIA (kW/Sec/kVA)	0.958
QMIN (MVAR)	

The wind turbine generators have ride-through capability for voltage and frequency. Detailed relay settings are shown in the following tables for the Advanced Grid Option (AGO) package.

Table 2 Over/Under Frequency Relay Settings for Vestas V-90 WTG

Frequency Settings in Hertz	Time Delay in Seconds	Breaker time in Seconds
$F \leq 52.5$	0.2	0.08
$55.5 < F \leq 57.0$	2.0	0.08
$63.0 > F \geq 62.0$	90.0	0.08
$F \geq 62.5$	0.2	0.08

Table 3 Over/Under Voltage Relay Settings for Vestas V-90 WTG

Voltage Settings Per Unit	Time Delay in Seconds	Breaker time in Seconds
$V \leq 0.15$	0.35	0.08
$0.15 < V \leq 0.75$	2.65	0.08
$0.75 < V \leq 0.85$	10.0	0.08
$0.85 < V \leq 0.90$	300	0.08
$V \geq 1.10$	60	0.08
$1.10 > V \geq 1.15$	60	0.08
$1.15 > V \geq 1.2$	2.0	0.08
$1.2 > V \geq 1.25$	0.08	0.08

### 3.3 Assumptions

The following assumptions were adopted for the study:

1. Constant maximum and uniform wind speed for the entire period of study.
2. Wind turbine control models with their default values.
3. Under/over voltage/frequency protection set to standard manufacturer data.

### 3.4 Faults Simulated

Fourteen (14) faults were considered for the transient stability simulations which included three phase faults, as well as single phase line faults, at the locations defined by SPP. Single-phase line faults were simulated by applying a fault impedance to the positive sequence network at the fault location to represent the effect of the negative and zero sequence networks on the positive sequence network. The fault impedance was computed to give a positive sequence voltage at the specified fault location of approximately 60% of pre-fault voltage. This method is in agreement with SPP current practice. Table 4 shows the list of simulated contingencies. The table also shows the fault clearing time and the time delay before re-closing for all the study contingencies.

Table 4 List of Contingencies

<b>Dist. No.</b>	<b>Case ID</b>	<b>Description (Time in cycles after fault)</b>
1	F01-3PH	3-phase fault at Concordia on 115 kV line to Clifton <u>Time</u> <u>Fault Clearing</u> 7   Trip breaker at Concordia for line 58757[CONCORD3]-58756[CLIFTON3] 9   Clear fault
2	F01-SLG	SLG fault at Concordia on 115 kV line to Clifton, Breaker failure at Concordia, [CB3900] <u>Time</u> <u>Fault Clearing</u> 9   Trip breaker at Clifton for line 58757[CONCORD3]-58756[CLIFTON3] 30   Trip line 58793[SMITH-C3]-58769[JEWELL 3] Trip line 58793[SMITH-C3]-58763[GLENELD3] Trip line 58758[CONCORD6]-59356[CLOUDTAP] Clear fault
3	F02-3PH	3-phase fault at Concordia on 230 kV line to Cloud Tap <u>Time</u> <u>Fault Clearing</u> 5   Trip breaker at Concordia for line 58758[CONCORD6]-59356[CLOUDTAP] 7   Clear fault
4	F02-SLG	SLG fault at Concordia on 230 kV line to Cloud Tap, Interrupter failure at Concordia, [#6001] <u>Time</u> <u>Fault Clearing</u> 7   Trip breaker at Cloud Tap for line 58758[CONCORD6]-59356[CLOUDTAP] 16   Trip line 58793[SMITH-C3]-58769[JEWELL 3] Trip line 58793[SMITH-C3]-58763[GLENELD3] Trip line 58757[CONCORD3]-58756[CLIFTON3] Clear fault
5	F03-3PH	3-phase fault at Cloud Tap on 230 kV line to East Manhattan <u>Time</u> <u>Fault Clearing</u> 6   Trip breaker at Cloud Tap for line xxxxxx[CLOUDTAP] - 56861[EMANHAT6] 12   Clear fault
6	F03-SLG	SLG fault at Cloud Tap on 230 kV line to East Manhattan, Breaker failure at East Manhattan <u>Time</u> <u>Fault Clearing</u> 5   Trip breaker at Cloud Tap for line xxxxxx[CLOUDTAP] - 56861[EMANHAT6] 30   Trip line 56861[EMANHAT6]-56852[JEC 6] Clear fault

7	F04-3PH	3-phase fault at East Manhattan on 230 kV line to Cloud Tap <u>Time</u> <u>Fault Clearing</u> 7        Trip breaker at Cloud Tap for line xxxxxx[LOUDTAP] - 56861[EMANHAT6] 10       Clear fault
8	F04-SLG	SLG fault at East Manhattan on 230 kV line to Cloud Tap, Breaker failure at Cloud Tap <u>Time</u> <u>Fault Clearing</u> 10       Trip breaker at East Manhattan for line xxxxx[LOUDTAP] -56861[EMANHAT6] 16       Trip line 58758[CONCORD6]-xxxxx[LOUDTAP] Clear fault
9	F05-3PH	3-phase fault at Cloud Tap on 230 kV line to Concordia <u>Time</u> <u>Fault Clearing</u> 5        Trip breaker at Cloud Tap for line xxxx[LOUDTAP] - [Concordia] 12       Clear fault
10	F05-SLG	SLG fault at Cloud Tap on 230 kV line to Concordia <u>Time</u> <u>Fault Clearing</u> 5        Trip breaker at Cloud Tap for line xxxxxx[LOUDTAP] - [Concordia] Clear fault
11	F06-3PH	3-phase fault at E Manhattan on the line to JEC <u>Time</u> <u>Fault Clearing</u> 5        Trip line 56861[EMANHAT6]-56852[JEC 6] 7        Clear fault
12	F06-3PH	3-phase fault at E Manhattan on the line to JEC <u>Time</u> <u>Fault Clearing</u> 5        Trip line 56861[EMANHAT6]-56852[JEC 6] 7        Clear fault
13	F07-3PH	3-phase fault at Concordia on 115 kV line to Jewell <u>Time</u> <u>Fault Clearing</u> 5        Trip breaker at Concordia for line 58757[CONCORD3] - 58769[JEWELL] 7        Clear fault
14	F08-3PH	3-phase fault at Concordia on 115 kV line to Glen Elder <u>Time</u> <u>Fault Clearing</u> 5        Trip breaker at Concordia for line 58757[CONCORD3] - 58750[BELOIT] – 58763[GLENELD] 7        Clear fault

### 3.5 Simulation Results

Simulations were performed with a 0.1-second steady-state run followed by the appropriate disturbance as described in Table 4. Simulations were run for a minimum 10-second duration to confirm proper machine damping.

With Vestas V-90 3.0 MW WTG, the proposed 201 MW wind farm was modeled with under/over voltage/frequency ride through protection. The settings were in accordance with standard or default settings for the Advanced Grid Option (AGO) package

The simulation results showed that:

- For summer peak and winter peak loading conditions, the proposed 201 MW wind farm tripped for one fault; fault # 8 (SLG fault at East Manhattan on 230 kV line to Cloud Tap with Breaker failure at Cloud Tap) out of the fourteen (14) faults simulated. However, the tripping of the wind farm for this fault is because the fault clearing procedures leave the wind farm residing in an isolated island. Additionally, for winter peak loading conditions, the wind farm tripped for fault #7 (3-phase fault at East Manhattan on 230 kV line to Cloud Tap) due to relay actuation on low voltage.
- For winter loading conditions, further analysis for those faults where there was no tripping of the proposed 201 MW wind farm showed that post-fault voltage did not recover fully and oscillatory voltage behavior was observed for faults # 5 and # 6 (3-phase fault at Cloud Tap on 230 kV line to East Manhattan, and SLG fault at Cloud Tap on 230 kV line to East Manhattan, Breaker failure at East Manhattan). This oscillatory voltage behavior was not observed for the same faults in the summer peak loading conditions.
- Consequently, dynamic voltage support is recommended comprising of two STATCOMs located at the low voltage side of the 230/34.5 kV grid transformers. It was found that a STATCOM with a short term rating (2 seconds) of approximately 10 MVAR and a continuous rating of 4 MVAR would be sufficient. The STATCOMs were set to float during normal conditions with MVAR outputs close to zero.
- For both summer and winter loading conditions, prior queued project GEN-2002-026, a 121 MW wind farm consisting of Vestas V80 WTGs on the McDowell – Morris County 230 kV line, tripped for faults # 7 and 11. The trippings were all due to relay actuation on low voltage. According to the scope of work, faults # 7 and 11 (3-phase fault at East Manhattan on 230 kV line to Cloud Tap, and 3-phase fault at E Manhattan on the line to JEC) were re-run with the LVRT protection disabled. The results showed that all oscillations were well damped and no trippings were detected.

With this recommended two 4-MVAR STATCOMs, all oscillations are well damped. The study finds that the proposed 201 MW wind farm project shows stable performance with the aforementioned operating schemes and reinforcement of SPP system for the contingencies tested on the supplied base cases.

## 4. Conclusion

The stability simulation findings of the impact study of a proposed interconnection (Gen-2003-006A) were presented in this report. The study was conducted through the Southwest Power Pool Tariff for a 230 kV 201 MW wind farm in Cloud County, Kansas. This wind farm will be interconnected to a new station on the Concordia – E. Manhattan 230 kV transmission line owned Mid Kansas Electric Corporation (affiliate of Sunflower) formerly West Plains Electric. The impact study case considered 100% MW of the wind farm proposed output. Vestas V-90 3.0 MW WTGs were studied according to the customer request.

With Vestas V-90 3.0 MW WTG, the proposed 201 MW wind farm was modeled with under/over voltage/frequency ride through protection. The settings were in accordance with standard or default settings for the Advanced Grid Option (AGO) package. The simulation results showed that:

- For summer peak and winter peak loading conditions, the proposed 201 MW wind farm tripped for one fault; fault # 8 (SLG fault at East Manhattan on 230 kV line to Cloud Tap with Breaker failure at Cloud Tap) out of the fourteen (14) faults simulated. However, the tripping of the wind farm for this fault is because the fault clearing procedures leave the wind farm residing in an isolated island. Additionally, for winter peak loading conditions, the wind farm tripped for fault #7 (3-phase fault at East Manhattan on 230 kV line to Cloud Tap) due to relay actuation on low voltage.
- For winter loading conditions, further analysis for those faults where there was no tripping of the proposed 201 MW wind farm showed that post-fault voltage did not recover fully and oscillatory voltage behavior was observed for faults # 5 and # 6 (3-phase fault at Cloud Tap on 230 kV line to East Manhattan, and SLG fault at Cloud Tap on 230 kV line to East Manhattan, Breaker failure at East Manhattan). This oscillatory voltage behavior was not observed for the same faults in the summer peak loading conditions.
- Consequently, dynamic voltage support is recommended comprising of two STATCOMs located at the low voltage side of the 230/34.5 kV grid transformers. It was found that a STATCOM with a short term rating (2 seconds) of approximately 10 MVAR and a continuous rating of 4 MVAR would be sufficient. The STATCOMs were set to float during normal conditions with MVAR outputs close to zero.
- For both summer and winter loading conditions, prior queued project GEN-2002-026, a 121 MW wind farm consisting of Vestas V80 WTGs on the McDowell – Morris County 230 kV line, tripped for faults # 7 and 11. The trippings were all due to relay actuation on low voltage. According to the scope of work, faults # 7 and 11 (3-phase fault at East Manhattan on 230 kV line to Cloud Tap, and 3-phase fault at E Manhattan on the line to JEC) were

re-run with the LVRT protection disabled. The results showed that all oscillations were well damped and no trippings were detected.

With this recommended two 4-MVAR STATCOMs, all oscillations are well damped. The study finds that the proposed 201 MW wind farm project shows stable performance with the aforementioned operating schemes and reinforcement of SPP system for the contingencies tested on the supplied base cases.