

Final Report

Summary of Generation Interconnection Study for Aquila Interconnection Queue Customer

Generation Addition: 150 MW Wind Farm near Spearville, Kansas

December 30, 2004

1.0 Introduction

A customer within the Aquila interconnection queue (Customer) has proposed adding up to 150 MW of wind generation near Spearville, Kansas (projected in-service date of December 2005). The proposed generation would interconnect with the Aquila, Inc. transmission system (WestPlains Energy operating division, denoted WEPL) at the existing 230/115/34.5 kV Spearville Substation at the 230 kV voltage level. The purpose of this interconnection study was to evaluate the system impacts on the WEPL transmission system and those in the immediate surrounding area due to interconnecting this generation at this site. Additionally, this study quantified approximate costs for mitigating the identified WEPL transmission system impacts.

Note that the results of this study do not constitute a guarantee of transmission service from the proposed location to load within the WEPL system or to the WEPL system border. Additional study will be required to assess the full impacts and costs of granting transmission service.

2.0 Model Development

Models representing the WEPL system as well as the surrounding bulk electric transmission system were developed for each of the studies performed. In each case, the most recently available Southwest Power Pool (SPP) or internal Aquila model was used as the starting point.

2.1 Load Flow Model

The output of a wind farm is known to be unpredictable and relatively uncontrollable. Because of this, the wind farm could be at full output at any time during the year. Therefore, the interconnection of the proposed wind generation was evaluated for a full range of available SPP seasonal load flow models (from the 2004 series) including the following:

- 2005 April Minimum (05AP)
- 2005 Summer Shoulder (05SH)
- 2005 Summer Peak (05SP)
- 2005 Fall Peak (05FA)
- 2005/06 Winter Peak (05WP)
- 2005 Spring Peak (05G)
- 2010 Summer Peak (10SP)

Each of these base case models were modified to include the full 110 MW output of the existing Gray County Wind Energy wind farm near Montezuma, Kansas. Additionally, proposed generation ahead of the proposed Customer project in the WEPL interconnection queue was added to the appropriate cases as detailed in table 1. Table 1 also shows projected system improvements required to dispatch the added generation.

Note that should any of these projects not materialize, the impacts of the proposed Customer project will also be altered.

Table 1 – Higher Queue Priority Projects added to Load Flow Cases

| Project Description | Size | System Improvements | Comments |
|-----------------------------------------------------------------|-------------|----------------------------------------------------------------------------------------------------------------------------------------------------------------------------------------------------------------------------------------------------------------------------------------------------------------------------------------------------------------------------------------------------------------------------------------------------------------------------------------------------------------------------|---------------------------------------------|
| Wind Farm in Kiowa County – assumed in service by December 2005 | 105 MW | <ol style="list-style-type: none"> 1. Relay upgrade on Judson Large to Medicine Lodge line on Judson Large terminal. 2. Replacement of wave traps on Judson Large to Medicine Lodge line. 3. Replacement of Medicine Lodge 138/115 kV transformer with 70 MVA unit. Also may raise rating on Medicine Lodge to Harper line to 95 MVA. 4. Upgrade of Kiowa tap to Greensburg line to allow 100C operation. 5. Change breaker failure relay time delay at N Judson Large. | Project presently in Facilities Study stage |

The proposed Customer facility was modeled at 34.5 kV connected directly into the 230 kV bus at Spearville via a 230/34.5 kV transformer. As directed by the Customer, the turbine assumed for this project as a 1.5 MW GE Wind turbine. The turbines were lumped on the Customer 34.5 kV bus and assumed to have an available reactive capability range of 95 percent lagging and leading. The MW output was dispatched east to Ameren’s control area.

Should the Customer select a different turbine for this project, additional analysis will need to be conducted regarding appropriate reactive compensation.

2.2 Short Circuit Model

Aquila’s internal short circuit model with the addition of the higher queue order project was utilized to assess the short circuit impact of the proposed wind farm. The 230/34.5 kV transformer was explicitly modeled, assuming an impedance of 5 percent on a 110 MVA base. Wind turbines within each wind farm in the model were assumed to self-excite for the length of time of a fault event due to capacitor banks and inertial mass of the respective wind farms.

2.3 Stability Model

The 2005 Summer Peak stability base case from the SPP 2004 series was used as a basis for stability analysis. The base model was modified to increase output from the Gray County Wind Energy wind farm to its maximum and to include the higher queue order generation project. Additionally, a winter peak stability case was developed using the dynamic model data in the SPP base case. The most recent pss/e version of the GE 1.5

MW wind turbine model was used to model the higher queue order project as well as the proposed Customer project. Note that if a different turbine is ultimately selected, this analysis will no longer be valid.

3.0 Load Flow Analysis

The load flow impacts of the proposed generation were analyzed using the models described in Section 2.2. All single contingencies within five buses of the proposed interconnection bus, all single contingencies within five buses of the Concordia 230 kV bus, any additional single contingencies within the WEPL area not already covered, and more probable double contingencies on the WEPL system (such as breaker failure events) were performed for each of the seasonal models. The cases with the proposed wind farm added were compared with the appropriate base case to determine facility overload and/or voltage violations that were attributable to the proposed wind farm. The impacts that arose from this analysis have been classified in two groups: 1 – interconnection issues; 2 – transmission service issues. Interconnection issues were defined as those that would require mitigation in order for Aquila to provide interconnection service. Transmission service issues were defined as those that may require mitigation in order to deliver the proposed project’s output to end-use load either in or out of the WEPL control area. The transmission service issues identified are included primarily for informational purposes and could differ depending on the sink. Aquila has not attempted to develop full solutions for the transmission service issues.

3.1 Interconnection Issues

The interconnection of the proposed Customer project did not result in any new overloads in the vicinity of proposed interconnection for single contingencies. Therefore, the only interconnection issue determined in this study was the addition of a 230 kV position in the Spearville Substation to accommodate the interconnection. There were some new overloads for double contingencies at the Spearville 230 kV bus that occurred when the proposed project was placed in service (see Table 2). These events qualify as NERC category C events within the NERC planning standards. As such, it was assumed that these impacts would be mitigated by curtailing transactions from the proposed project. Also, the option may also exist to re-configure the 230 kV bus, due to the breaker addition, to eliminate the outage combinations cited in Table 2.

Note that each of the constraints identified in Table 2 were also identified as transmission service issues associated with single contingencies (see Section 3.2).

Table 2 – List of Double Contingency Issues Associated with Customer Generation Addition

| Constraint | Contingency(ies) | Worst Overload | Cases | Comments |
|--------------------------------|-----------------------------------------------------------------------------------------------------------|-----------------------|-----------------------|------------------------------------------------------------------------------------------------------------------------------------------------------------------------|
| Medicine Lodge – Harper 138 kV | Spearville 345/230 kV and Spearville 230/115 kV; Mullergren – Spearville 230 kV and Spearville 230/115 kV | 105.8% | 05AP, 05G, 05FA | Breaker failure of breaker 6030 or 6026 at Spearville. Combination could be altered depending on where proposed project is interconnected in the Spearville 230kV bus. |
| Greensburg – Sun City 115 kV | Mullergren – Spearville 230 kV and Spearville 230/115 kV | 109.3% | 05AP, 05G, 05SH, 05FA | Breaker failure of breaker 6030 at Spearville. Combination could be altered depending on where proposed project is interconnected in the Spearville 230kV bus. |

3.2 Transmission Service Issues

Some system violations noted during this analysis were not directly related to the immediate area of proposed interconnection. These issues have been included in this report for informational purposes. Note that this study does not constitute a transmission service study. Additional study would be required should transmission service be requested. Transmission service issues that were identified are listed in Table 3.

Table 3 – List of Transmission Service Issues Associated With Customer Generation Addition

| Constraint | Contingency(ies) | Worst Overload | Cases | Comments |
|--------------------------------|----------------------------------------------------------------------------------------------------------------|-----------------------|------------------|----------------------------------------------------------------------------------------------------------|
| Medicine Lodge – Harper 138 kV | Mullergren – Circle 230 kV; Spearville – N Judson 115 kV; Spearville 230/115 kV; Medicine Lodge – Pratt 115 kV | 102.2% | 05AP, 05G, 05FA, | Limit is current transformers. May be eliminated by by upgrade of Medicine Lodge 138/115 kV transformer. |
| Greensburg – Sun City 115 kV | Mullergren – Spearville 230 kV | 101.1% | 05G, 05FA, 10SP | Will require upgrading line to allow for 100C conductor temperature. |
| Auburn – JEC 230 kV | JEC – Hoyt 345 kV | 101.6% | 05FA | Third party impact, will require mitigation through Westar Energy/SPP. |
| Seward 115/69 kV | Mullergren -Heizer 230/115 kV | 104.0% | 05SP | Third party impact, will require mitigation through Midwest Energy/SPP. |
| Circle – Moundridge 115 kV | JEC – Hoyt 345 kV | 113.1% | 05SP | Third party impact, will require mitigation through Westar Energy/SPP. |
| Gatz – GoldplJ 69 kV | JEC – Hoyt 345 kV | 102.8% | 05SP | Third party impact, will require mitigation through Westar Energy/SPP. |

4.0 Short Circuit Analysis

Three-phase and single-line-to-ground fault currents were calculated before and after the addition of the proposed generation using the model described in Section 2.2. The results are shown in Table 4.

Table 4 - Maximum Fault Currents Before and After Proposed Wind Farm Addition

| Bus | Maximum Fault Current (kA) | |
|---------------------|-----------------------------------|-----------------------|
| | Before Addition | After Addition |
| Judson Large 115 kV | 9.27 | 9.95 |
| Spearville 115 kV | 8.08 | 8.86 |
| Spearville 230 kV | 5.01 | 6.14 |

The fault currents with the proposed generation addition in service were subsequently compared with the interrupting ratings of the breakers at Spearville and Judson Large. The maximum fault levels after the wind farm addition were within the rated capabilities of the existing equipment.

5.0 Stability Analysis

The angular stability impacts of the proposed wind farm addition were assessed using the models described in Section 2.3. The events simulated are shown in Table 4.

TABLE 4: DISTURBANCE DEFINITIONS FOR STABILITY STUDY

| Case ID | Description (Time in cycles after fault) |
|---------|--------------------------------------------------------------------------------------------------------------------------------------------------------------------------------------------------------------------------------------------------------------------------------------------------------------------------------------------------------------|
| F05-3PH | 3-phase fault at Mullergren on 230 kV line to Spearville <u>Time</u> <u>Fault Clearing</u> 5 Trip breaker at Mullergren for line 58779[MULGREN6] -58795[SPEARVL6] 7 Clear fault |
| F05-SLG | SLG fault at Mullergren on 230 kV line to Spearville, Breaker failure at Mullergren, [CB6012] <u>Time</u> <u>Fault Clearing</u> 7 Trip breaker at Spearville for line 58779[MULGREN6] -58795[SPEARVL6] 16 Trip line 58779[MULGREN6]-56871[CIRCLE6] Clear fault |
| F06-3PH | 3-phase fault at Spearville on 230 kV line to Mullergren <u>Time</u> <u>Fault Clearing</u> 5 Trip breaker at Spearville for line 58779[MULGREN6] -58795[SPEARVL6] 7 Clear fault |
| F06-SLG | SLG fault at Spearville on 230 kV line to Mullergren, Breaker failure at Mullergren, [CB6012] <u>Time</u> <u>Fault Clearing</u> 5 Trip breaker at Spearville for line 58795[SPEARVL6]-58779[MULGREN6] 16 Trip line 58779[MULGREN6]-56871[CIRCLE6] Clear fault |
| F07-3PH | 3-phase fault at North Judson Large on 115 kV line to Spearville <u>Time</u> <u>Fault Clearing</u> 7 Trip breaker at North Judson Large for line 58871[NOR-JUD3] -58794[SPEARVL3] 9 Clear fault |
| F07-SLG | SLG fault at North Judson Large on 115 kV line to Spearville Breaker failure at North Judson Large, [CB3071] <u>Time</u> <u>Fault Clearing</u> 9 Trip breaker at Spearville for line 58871[NOR-JUD3] -58794[SPEARVL3] 20 Trip line 58871[NOR-JUD3] -58771[JUD-LRG3] Trip line 58767[HAGGARD3]-58799[W-DODGE3] Clear fault |

TABLE 4: DISTURBANCE DEFINITIONS FOR STABILITY STUDY (CONT'D)

| Fault ID | Description (Time in cycles after fault) |
|-----------------|-----------------------------------------------------------------------------------------------------------------------------------------------------------------------------------------------------------------------------------------------------------------------------------------------------------------------------------------------------------------------------------------------------------------------------------------------------------------------------------------------------------------------------------------------------------------------|
| F08-3PH | <p>3-phase fault at Judson Large on 115 kV line to Clipper Tap</p> <p><u>Time</u> <u>Fault Clearing</u></p> <p>7 Trip breaker at Judson Large for line 58771[JUD-LRG3] -59350[CLIPTAP]</p> <p>9 Clear fault</p> |
| F08-SLG | <p>SLG fault at Judson Large on 115 kV line to Clipper Tap Breaker failure at Judson Large, [CB3629]</p> <p><u>Time</u> <u>Fault Clearing</u></p> <p>9 Trip breaker at Spearville for 58771[JUD-LRG3] -59350[CLIPTAP]</p> <p>20 Trip line 58771[JUD-LRG3] -58871[NOR-JUD3]</p> <p> Trip line 58771[JUD-LRG3] -58840[EDODGE3]</p> <p> Trip line 58754[CIM-PLT3] - 58752[CMRIVTP3]</p> <p> Trip line 58772[E-LIBER3] -58752[CMRIVTP3]</p> <p>30 Trip generator at 58770[JUD-LRG1]</p> <p> Clear fault</p> |
| F09-3PH | <p>3-phase fault at Clipper Tap on 115 kV line to Greensburg</p> <p><u>Time</u> <u>Fault Clearing</u></p> <p>7 Trip breaker at Clipper Tap for line 59350[CLIPTAP] -58764[GRNBURG3]</p> <p>9 Clear fault</p> |
| F09-SLG | <p>SLG fault at Clipper Tap on 115 kV line to Greensburg Breaker failure at Medicine Lodge, [CB3102]</p> <p><u>Time</u> <u>Fault Clearing</u></p> <p>7 Trip breaker at Clipper Tap for line 59350[CLIPTAP] -58764[GRNBURG3]</p> <p>20 Trip line 58773[MED-LDG3] -58797[SUNCITY3]</p> <p> Clear fault</p> |

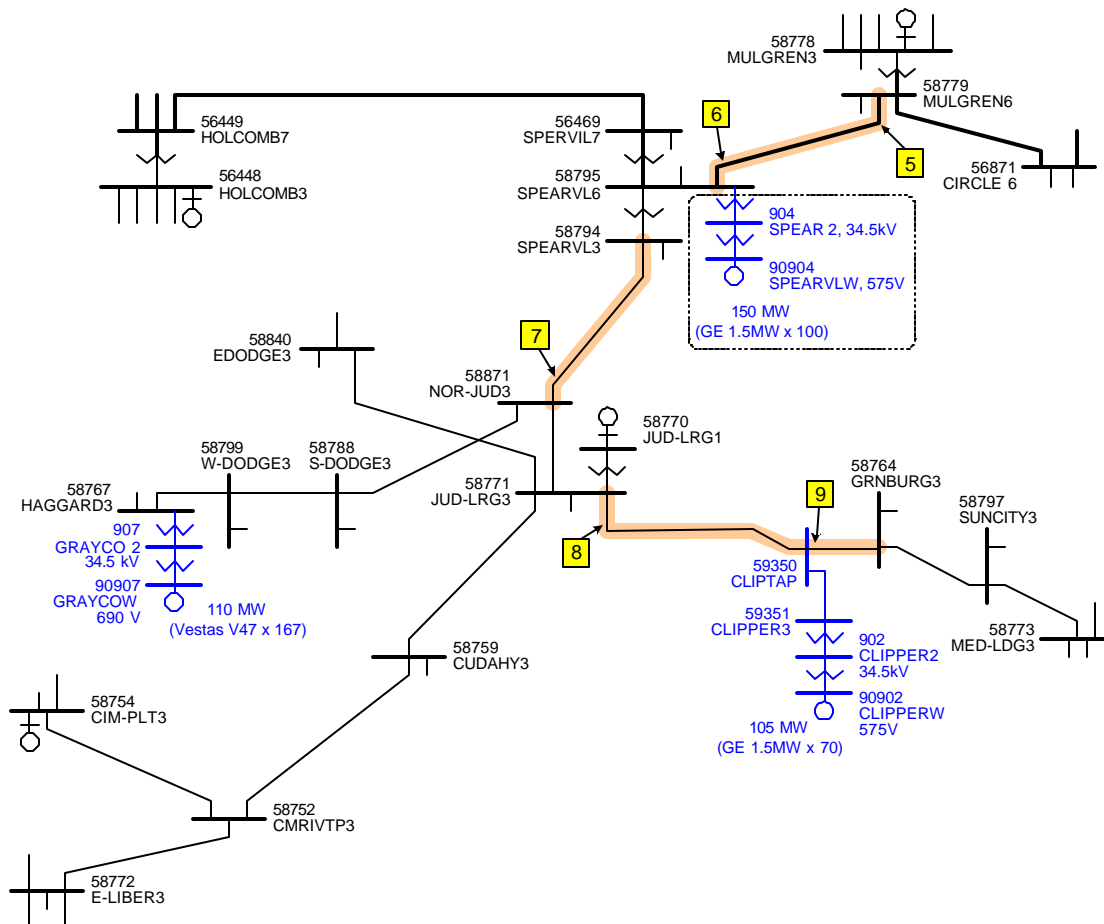

FIGURE 1: FAULT LOCATIONS NEAR SPEARVILLE WIND FARM

Table 5 summarizes the results of the stability simulations described in Table 4 with the proposed Customer project and the higher queue order project modeled. The results show that the existing Gray County wind farm exhibited some unstable oscillatory responses to some of the events simulated. To fairly establish the role of the proposed Customer project in these oscillatory responses, the simulations were performed without the proposed Customer project. The results of this analysis are summarized in Table 6. Table 6 illustrates that the oscillatory behavior observed is not due to the proposed Customer project. Therefore, it was determined that the proposed Customer project did not negatively impact system stability. This assumed selection of the GE wind turbine, as directed by the Customer. Should a different turbine be selected, these results will need to be re-studied with an appropriate model for the new turbine.

TABLE 5: STABILITY SIMULATION RESULTS

| Fault ID | Description | Stability Result | | | | | |
|----------|------------------------------------------------------------------------------------------------------------------|------------------|----|----|-------------|----|----|
| | | 2004 Winter | | | 2005 Summer | | |
| | | GC | KW | SP | GC | KW | SP |
| F05-3PH | 3-phase fault at Mullergren on 230 kV line to Spearville | S | | X | X | | X |
| F05-SLG | SLG fault at Mullergren on 230 kV line to Spearville Breaker failure at Mullergren, [CB6012] | U | | | U | | |
| F06-3PH | 3-phase fault at Spearville on 230 kV line to Mullergren | X | | X | X | | X |
| F06-SLG | SLG fault at Spearville on 230 kV line to Mullergren Breaker failure at Mullergren, [CB6012] | S | | | U | | |
| F07-3PH | 3-phase fault at North Judson Large on 115 kV line to Spearville | X | X | | X | X | |
| F07-SLG | SLG fault at North Judson Large on 115 kV line to Spearville, Breaker failure at North Judson Large, [CB3071] | X | X | | X | X | |
| F08-3PH | 3-phase fault at Judson Large on 115 kV line to Clipper Tap | X | X | | X | X | |
| F08-SLG | SLG fault at Judson Large on 115 kV line to Clipper Tap Breaker failure at Judson Large, [CB3629] | X | X | | X | X | |
| F09-3PH | 3-phase fault at Clipper Tap on 115 kV line to Greensburg | X | X | | X | X | |
| F09-SLG | SLG fault at Clipper Tap on 115 kV line to Greensburg Breaker failure at Medicine Lodge, [CB3102] | S | X | | U | X | |

GC: Gray County, KW: Kiowa County project, SP: Customer Spearville project
X: wind turbines tripped, U: unstable oscillation, S: sustained oscillation

TABLE 6: STABILITY SIMULATION RESULTS (W/O CUSTOMER PROJECT)

| Fault ID | Description | Stability Result | | | | | |
|----------|------------------------------------------------------------------------------------------------------------------|------------------|----|----|-------------|----|----|
| | | 2004 Winter | | | 2005 Summer | | |
| | | GC | CL | SP | GC | CL | SP |
| F05-3PH | 3-phase fault at Mullergren on 230 kV line to Spearville | S | | | X | | |
| F05-SLG | SLG fault at Mullergren on 230 kV line to Spearville Breaker failure at Mullergren, [CB6012] | S | | | U | | |
| F06-3PH | 3-phase fault at Spearville on 230 kV line to Mullergren | X | | | X | | |
| F06-SLG | SLG fault at Spearville on 230 kV line to Mullergren Breaker failure at Mullergren, [CB6012] | S | | | U | | |
| F07-3PH | 3-phase fault at North Judson Large on 115 kV line to Spearville | X | X | | X | X | |
| F07-SLG | SLG fault at North Judson Large on 115 kV line to Spearville, Breaker failure at North Judson Large, [CB3071] | X | X | | X | X | |
| F08-3PH | 3-phase fault at Judson Large on 115 kV line to Clipper Tap | X | X | | X | X | |
| F08-SLG | SLG fault at Judson Large on 115 kV line to Clipper Tap Breaker failure at Judson Large, [CB3629] | X | X | | X | X | |
| F09-3PH | 3-phase fault at Clipper Tap on 115 kV line to Greensburg | X | X | | X | X | |
| F09-SLG | SLG fault at Clipper Tap on 115 kV line to Greensburg Breaker failure at Medicine Lodge, [CB3102] | S | X | | U | X | |

GC: Gray County, KW: Kiowa County project, SP: Customer Spearville project
X: wind turbines tripped, U: unstable oscillation, S: sustained oscillation

6.0 Summary of Estimated Impact Mitigation Costs

Estimated costs for mitigating the impacts discussed previously within the Aquila transmission system were estimated as shown in Table 7.

Table 7 – Estimated Impact Mitigation Costs

| Facility | Estimated Cost | Comments |
|-----------------------------------------------------------------------------------------------------------------|-----------------------|----------------------------------------|
| Addition of one 230 kV position in the existing WEPL Spearville Substation for interconnecting Customer project | \$1,950,000 | Required interconnection service cost. |
| Upgrade of Greensburg to Sun City line to allow for 100C conductor temperature operation . | \$4,200,000 | Transmission Service impact. |

The estimated mitigation costs include a tax gross-up to cover anticipated income tax consequences (estimated at 20 percent). Note that the costs presented here are preliminary and subject to change should a detailed facilities study be requested.

Note that the transmission service related estimates were included strictly for informational purposes. Additional study will be required should transmission service be requested.