



***Feasibility Study for Generation
Interconnection Request
For
GEN-2002-023***

***SPP Coordinated Planning
(#GEN-2002-023)***

August 2003

Executive Summary

<OMITTED TEXT> (Customer) has requested a feasibility study for the purpose of interconnecting 100 to 150 MW of wind generation in Carson County, Texas within the service territory of Southwestern Public Service Company (SWPS). The proposed point of interconnection is on SWPS circuit K53, a 230kV line between Grapevine and Nichols substations. The point of interconnection would be approximately 4 miles north of the town of Panhandle, Texas. A map of the area, Figure 2, is provided at the end of this document.

Power flow analysis has indicated that for the powerflow cases studied, it is possible to interconnect the 150 MW wind farm without significant transmission system reinforcements within the local Xcel Energy transmission system. In order to maintain acceptable bus voltage, the customer has proposed to install a switched capacitor bank on the 34.5 kV system. Dynamic Stability studies will provide guidance as to how much reactive compensation will be needed and whether the reactive compensation can be static or must be dynamic (such as a SVC). The Dynamic Stability type of analysis is typically performed during the System Impact Study.

The requirements for interconnection consist of building a 230kV interconnection facility configured in a 3-breaker ring bus configuration. One terminal of the new switch station would lead to Grapevine Interchange, another terminal would lead to Nichols substation and the third terminal would lead to the customer facility. If the customer's substation facility will be built close to the new switch station (less than one mile), a Certificate of Convenience and Necessity from the Public Utility Commission of Texas will not be required.

The total cost for this 230kV interconnection facility is estimated at \$3.39 million dollars, which is based on estimates provided by the Southwestern Public Service Company engineering department. The cost includes building 230kV from the customer substation facility into the new 3-breaker switch station, which was estimated at 1/2 mile (this could vary once the customers substation is located) and the cost to construct the 3-breaker ring bus switch station including all breakers and metering equipment.

This feasibility study does not take into account static system reinforcements triggered by other generation projects that are positioned ahead in the queue. In the event that these generation projects and the system reinforcements triggered by these projects are built, this feasibility study may have to be revisited, potentially changing the requirements necessary for interconnecting this customer's 150 MW wind farm.

The costs do not include any costs associated with the deliverability of the energy to final customers. These costs are determined by separate studies if the Customer requests transmission service through Southwest Power Pool's OASIS.

Introduction

The Customer has requested a Feasibility Study for interconnection of a 100 to 150MW wind generation facility in Carson County, Texas. The proposed point of interconnection is on SWPS circuit K53, a 230kV line between Grapevine and Nichols substations. The point of interconnection would be approximately 4 miles north of the town of Panhandle, Texas. A map of the area, Figure 2, is provided at the end of this document. The requested in-service date of the facility is November 2003.

Interconnection Facilities

The primary objective of this study is to identify the system problems associated with connecting the plant to the area transmission system and estimated costs of system modifications needed to alleviate the system problems.

The Feasibility and other subsequent Interconnection Studies are designed to identify attachment facilities and other direct assignment facilities needed to accept power into the grid at the interconnection receipt point.

The requirements for interconnection consist of tapping the Xcel Energy 230 kV transmission circuit K53 and building a 230 kV interconnection facility configured in a ring-bus. The facility will have at least five 230 kV breakers: three for the ring bus configuration, one for the interconnection to the Customer wind farm substation and one for each reactive power compensation facility. (If dynamic reactive compensation is utilized, the breaker scheme may be modified.) The new 230 kV transmission line that will interconnect with the wind farm is assumed to be located in close proximity to the new Xcel Energy 230 kV interconnection facility. A Certificate of Convenience and Necessity from the Public Utility Commission of Texas would not be required if this new 230 kV line is less than one mile. A one-line diagram of the proposed interconnection facility can be found in Figure 1 at the end of this document.

The total cost for this 230 kV interconnection facility is estimated at \$ 3.39 million dollars, which is based on estimates provided by the SWPS engineering department. The cost includes the new 230 kV interconnection facility tapping circuit K53, 1/2 mile of 230 kV transmission line from the interconnection facility to the wind farm collection substation, and right-of-way. This cost does include 2-28.8 MVar capacitor banks on the 230 kV for 150 MW. Dynamic Stability studies will provide guidance as to whether the reactive compensation can be static or must be dynamic (such as a SVC).

The costs of interconnecting the facility to the SWPS transmission system are listed in Table 1. **These costs do not include any cost that might be associated with short circuit study results or dynamic stability study results.** These costs will be determined when and if a System Impact Study is conducted.

Table 1: Interconnection Facilities

Facility	ESTIMATED COST (2003 DOLLARS)
Construct a new 3-breaker ring bus switch station on circuit K53	\$2,976,176
½ mile of 230kV line to the customer's wind farm	\$380,000
Right-of-Way	\$35,000
Total	\$3,391,176

Powerflow Analysis

A powerflow analysis was conducted for the facility using various seasonal representations. The output of the Customer's facility was offset in each model by a reduction in output of SWPS generation. Modified versions of the 02 Series Southwest Power Pool 2004 Spring Peak, 2004 Summer Peak, and 2009 Summer Peak base case were used for this study.

The analysis of the customer's project shows that the proposed location can handle the entire 150MW of output under steady state conditions without system upgrades in all seasons out to the end of SPP's planning horizon. The customer had requested that generation levels between 100MW and 150MW be studied to determine the level of generation that would trigger upgrades. As no upgrades were required at the maximum requested level of 150MW, it was deemed not necessary to study reduced levels of generation.

There are several other proposed wind generation additions in the general area of the Customer's facility. It was assumed in the analysis that not all of these other projects were in service. Those previously queued projects that have advanced to nearly complete phases were included in this feasibility study.

Powerflow Analysis Methodology

The Southwest Power Pool (SPP) criteria states that: The transmission system of the SPP region shall be planned and constructed so that the contingencies as set forth in the Criteria will meet the applicable *NERC Planning Standards* for System Adequacy and Security – Transmission System Table I hereafter referred to as NERC Table I) and its applicable standards and measurements.

Using the created models and the ACCC function of PSS\E, single contingencies in the SWPS control area were applied and the resulting scenarios analyzed. This satisfies the 'more probable' contingency testing criteria mandated by NERC and the SPP criteria.

Conclusion

The minimum cost of interconnecting the Customer project is estimated at \$3.39 million dollars. However, as stated earlier, previously queued projects were assumed to not be in service in this feasibility study. If any of those projects are constructed, then this feasibility study may have to be revisited to determine the impacts of this customer's project on other SWPS transmission facilities.

These interconnection costs do not include any cost that may be associated with short circuit or transient stability analysis. These studies will be performed if the Customer signs a system impact study agreement.

The costs do not include any costs associated with the deliverability of the energy to final customers. These costs are determined by separate studies if the Customer requests transmission service through Southwest Power Pool's OASIS.

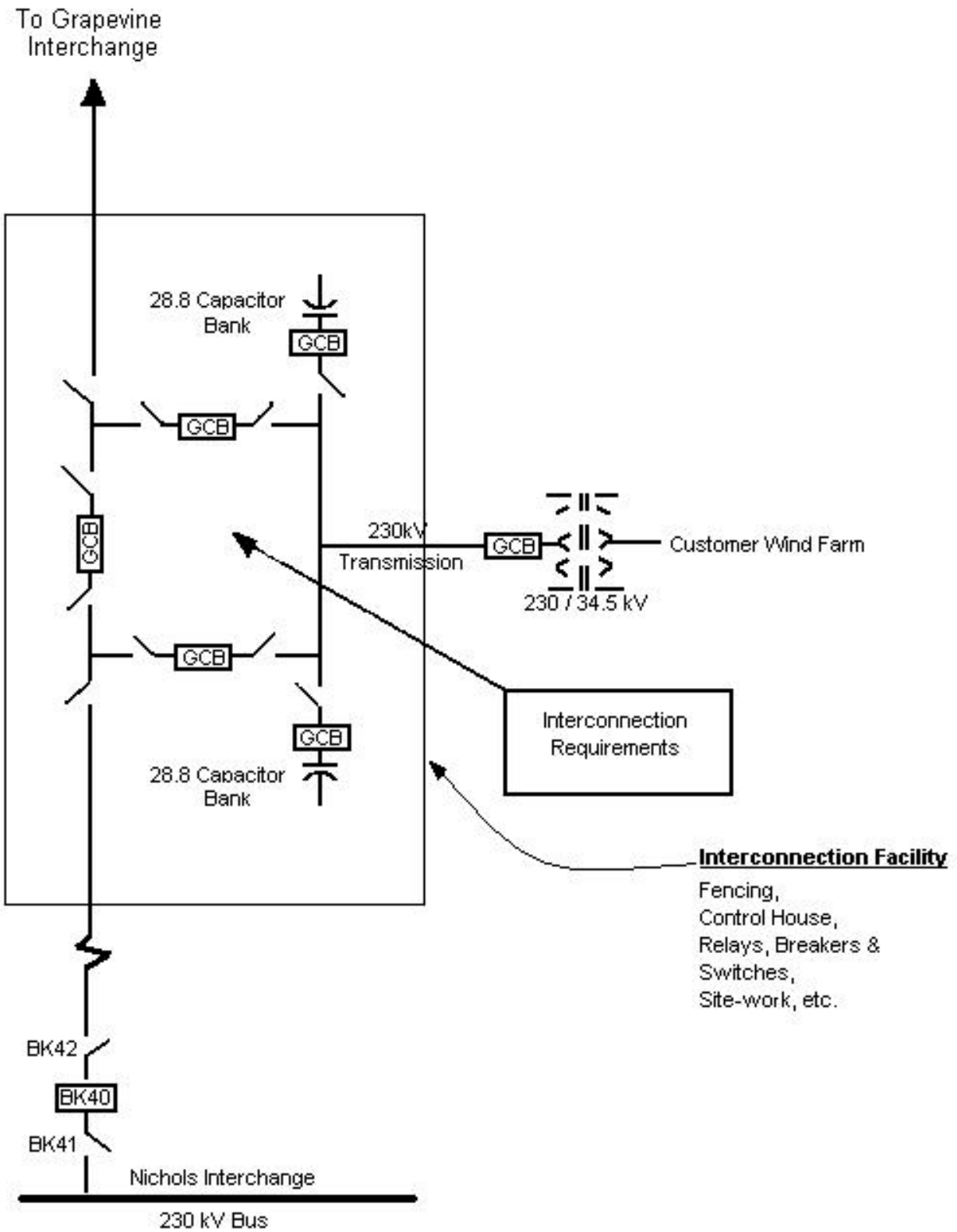

Figure 1. One-line Diagram of the 230 kV Interconnection

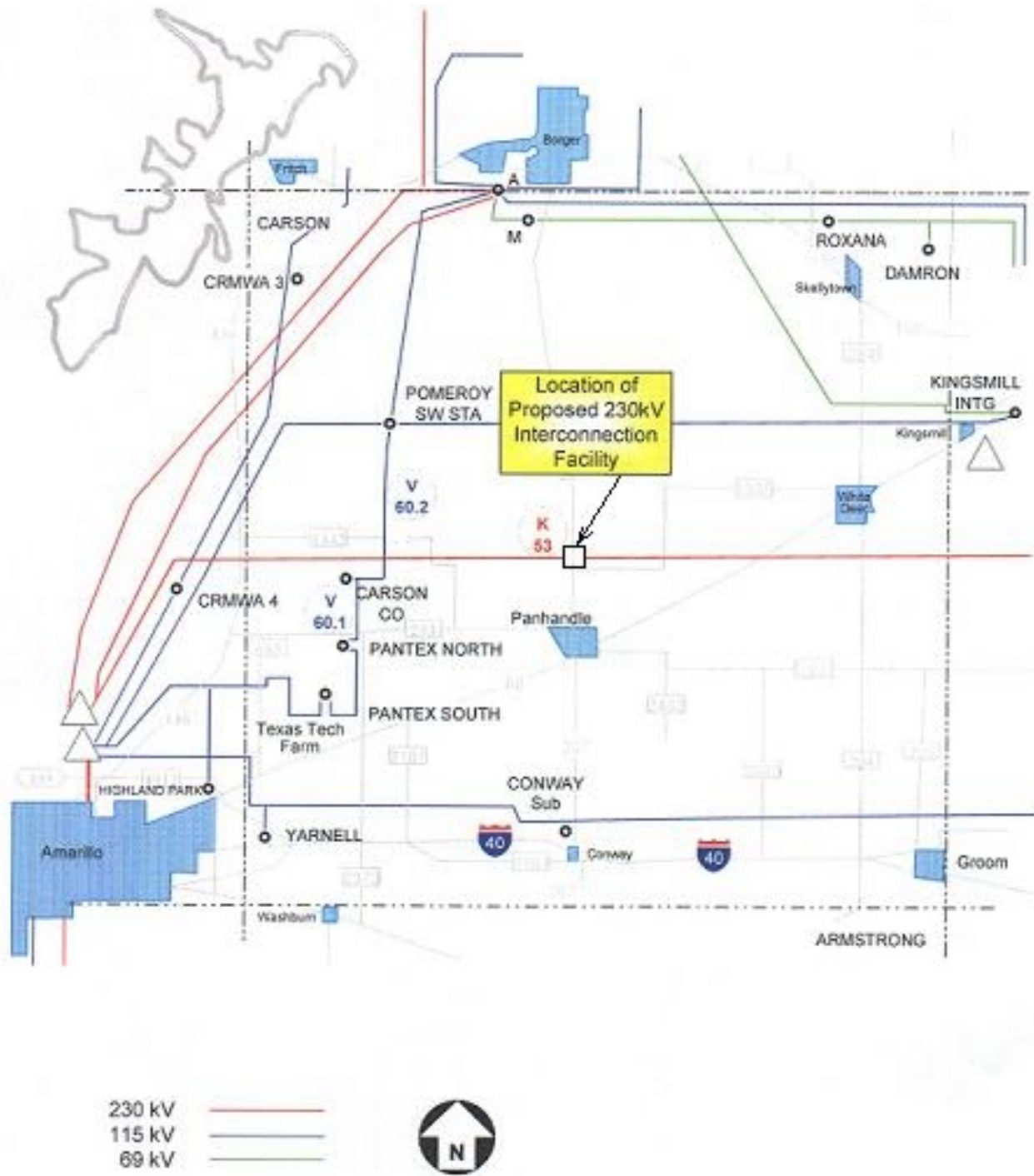

Figure 2. Local Transmission System