



***Impact Study
For
Generation Interconnection
Request
GEN-2002-022***

SPP Tariff Studies

(#GEN-2002-022)

August 2009

Executive Summary

<OMITTED TEXT> (Customer) has requested an Impact Study under the Southwest Power Pool Open Access Transmission Tariff (OATT) for interconnection of 79.2 MW of wind generation within the control area of Xcel Energy (SPS) in Oldham County, Texas. The Gen-2002-022 wind farm consists of two phases. Phase 1 is 160 MW which is now in commercial operation. Phase 2 is an additional 79.2 MW that will be interconnected to the SPS transmission system at the existing Bushland Interchange. Phase 2 is the subject of this report.

A stability study was conducted by consultants from the Black and Veatch Corporation, and the study report follows this summary. The stability study shows that the interconnection of the proposed project does not have any adverse impact on the system stability in the SPP area.

A Power Factor Analysis was conducted and the Customer's wind farm is required to maintain +/- 0.96 power factor at the point of interconnection (POI) for any system condition.

Nothing in this study should be construed as a guarantee of transmission service. If the customer wishes to sell power from the facility, a separate request for transmission service shall be requested on Southwest Power Pool's OASIS by the Customer.

**IMPACT STUDY FOR SPP GENERATION
QUEUE POSITION GEN-2002-022**

**SOUTHWEST POWER POOL (SPP)
August 06, 2009**

Final Report

By



BLACK & VEATCH

Table of Contents

<i>EXECUTIVE SUMMARY</i>	5
<i>1. INTRODUCTION</i>	6
<i>2. STABILITY STUDY CRITERIA</i>	6
<i>3. SIMULATION CASES</i>	7
<i>4. SIMULATION MODEL</i>	8
<i>5. STUDY ASSUMPTIONS</i>	9
<i>6. SIMULATION RESULTS</i>	9
<i>7. SUMMARY</i>	12

EXECUTIVE SUMMARY

A transient stability study was performed for Southwest Power Pool (SPP) Interconnection Queue Position GEN-2002-022 as part of the System Impact Study. The Interconnection Queue Position GEN-2002-022 is a wind farm of 79.2 MW (phase 2) capacity proposed to be added to the existing 160 MW (phase 1) wind farm in Oldham County, Texas. This wind farm would be interconnected to the Xcel Energy (SPS) transmission system at the existing Bushland Interchange.

Transient Stability studies were conducted with the full output of 79.2 MW (100%). The wind farm was considered to contain Mitsubishi 2.4 MW turbines.

The 2010 summer load flow case and 2010 winter load flow case together with the SPP MDWG 2006 stability model were used as the base case for the transient stability analysis. The study was performed using PTI's PSS/E program, which is an industry-wide accepted power system simulation program. The wind farm was modeled using the Mitsubishi wind turbine models provided by the customer.

Transient Stability studies were conducted with the GEN-2002-022 output at 79.2 MW (100%) for two scenarios, i.e., (i) summer peak load and (ii) winter peak load. Fourteen (14) contingencies were considered for each of the scenarios.

The study has not indicated any angular or voltage instability due to the addition of Gen-2002-022.

Power factor analysis indicated a need for 96% power factor (pf) at the Bushland 230 kV bus (the point of interconnection, POI). This interconnection request must meet this power factor requirement.

If any of the previously queued projects that were included in this study drop out, then this System Impact Study may have to be revised to determine the impacts of this Interconnection Customer's project on Xcel Energy's transmission facilities.

1. INTRODUCTION

This report discusses the results of a transient stability study performed for Southwest Power Pool (SPP) Interconnection Queue Position GEN-2002-022.

The Interconnection Queue Position GEN-2002-022 is a wind farm of 79.2 MW (phase 2) capacity proposed to be added to the existing 160 MW (phase 1) wind farm in Oldham County, Texas. This wind farm would be interconnected to the Xcel Energy (SPS) transmission system at the existing Bushland Interchange. The system one line diagram of the area near the Queue Position GEN-2002-022 is shown below.

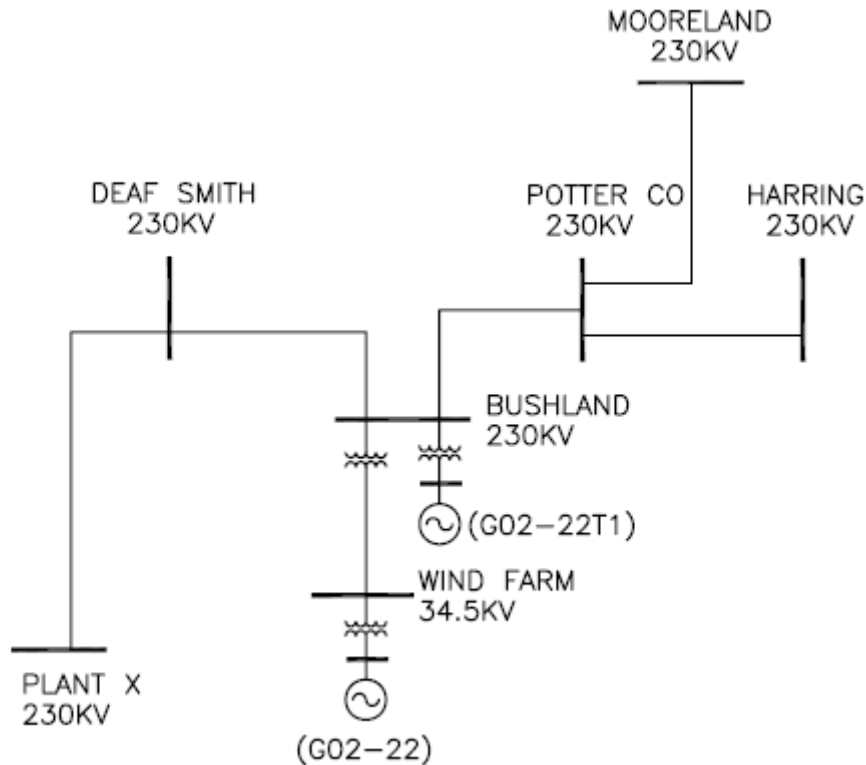

Figure 1: System One Line Diagram near GEN-2002-022

Transient Stability studies were conducted with the full output of 79.2 MW (100%). The wind farm was considered to contain Mitsubishi 2.4 MW wind turbines in the study.

2. STABILITY STUDY CRITERIA

The 2010 summer peak load flow and 2010 winter peak load flow cases together with the SPP MDWG 2006 stability model were used as the base case for the transient stability analysis. These models were provided by SPP.

Using Planning Standards approved by NERC, the following stability definition was applied in the Transient Stability Analysis:

“Power system stability is defined as that condition in which the difference of the angular positions of synchronous machine rotor becomes constant following an aperiodic system disturbance.”

Disturbances such as three phase and single phase line faults were simulated for a specified duration and the synchronous machine rotor angles were monitored for their synchronism following the fault removal.

The ability of the wind generators to stay connected to the grid during the disturbances and during the fault recovery was also monitored.

3. SIMULATION CASES

Transient Stability studies were conducted with the GEN-2002-022 output at 79.2 MW for (i) 2010 summer peak and (ii) 2010 winter peak load flow cases.

Table 1 indicates the contingencies that were studied for each of the two cases.

Fault	Fault Definition
FLT13PH	Three phase fault on the Potter County - Bushland 230 kV line, near Bushland.
FLT21PH	Single line-to-ground fault on the Potter County - Bushland 230 kV line, near Bushland.
FLT33PH	Three phase fault on the Potter County - Hitchland 230 kV line, near Hitchland.
FLT43PH	Three phase fault on the Coulter - Bushland 115 kV line, near Bushland.
FLT51PH	Single line-to-ground fault on the Coulter - Bushland 115 kV line, near Bushland.
FLT63PH	Three phase fault on the Harrington – Randall Interchange 230 kV line, near Randall..
FLT71PH	Single line-to-ground fault on the Harrington – Randall Interchange 230 kV line, near Randall..
FLT83PH	Three phase fault on the Bushland – Deaf Smith 230 kV line, near Bushland.
FLT91PH	Single line-to-ground fault on the Bushland – Deaf Smith 230 kV line, near Bushland.
FLT103PH	Three phase fault on the Grapevine – Stateline 230 kV line, near Stateline.
FLT111PH	Single line-to-ground fault on the Grapevine – Stateline 230 kV line, near Stateline.
FLT123PH	Three phase fault on the Wolfworth Interchange – Terry County 115 kV line, near Terry County.
FLT131PH	Single line-to-ground fault on the Wolfworth Interchange – Terry County 115 kV line, near Terry County.
FLT143PH	Three phase fault on the Bushland 230/115 kV autotransformer on the 230 kV bus.

Table 1: Study Cases

In all of the simulations, the fault duration was considered to be 5 cycles.

4. SIMULATION MODEL

The customer requested to use Mitsubishi 2.4 MW wind turbine for the System Impact Study. The Mitsubishi 2.4 wind turbine generator is a doubly fed induction generator. The following are the main electrical parameters of this wind turbine.

Rated Power : 2.4 MW
 Operating Nominal Voltage : 690V
 Operating Power Factor : 0.9 Lead to 0.95 Lag. (as per the Catalog)

The models of the Wind Farm equipment such as generators, transformers and cables were added to the base case for the purpose of this study. The equivalent generators of the wind farm were based on the number of collector circuits shown on the Customer provided single line diagram. Figure 2 shows the one line diagram of GEN-2002-022 modeled.

Table 2 provides the number of Mitsubishi 2.4 MW wind generators modeled as equivalents at each collector buses of the wind farm.

Collector Bus	No. of generators aggregated
1-2	2
3-4	2
4-6	3
7	1
9-10	2
11-13	3
16-21	6
22-24	3
28	2
29	1
30	1
31-34	4
35	1

Table 2: Equivalent Generators with Mitsubishi 2.4 MW Turbines

The Customer provided the wind turbine feeder conductor types, lengths and impedance values. Table 3 indicates the transmission line parameters, as provided by the Customer, were used in the model for the underground lines within the Wind Farm.

Conductor Size	Resistance (Ohms per 1000 ft)	Reactance (Ohms per 1000 ft)
4/0	0.107	0.048
500kcmil	0.045	0.043
1000 kcmil	0.023	0.039

Table 3: Cable impedance per 1000 feet

The PSS/E model for Mitsubishi wind turbines was provided by the customer.

The base case power flow diagram for the project GEN-2002-022 is shown in Figure 2.

5. STUDY ASSUMPTIONS

The following assumptions were made in the Study:

1. The wind speed over the entire wind farm was assumed to be uniform and constant during the study period.
2. From the wind turbine data sheets the protection settings were used as and are shown in Table 4.
3. The other generators in the SPP control area were scaled down to accommodate the new generation as indicated in Table 5.

Protective Function	Protection Setting	Time Delay
Over Frequency	61 Hz	0.3 seconds
Under Frequency	59.0 Hz	0.3 seconds
Under Voltage	85%	2.842
Under Voltage	55%	1.892
Under Voltage	2.5%	0.15
Over Voltage	110%	0.02 second

Table 4: Protective functions and settings for Mitsubishi 2.4 MW Turbines

Scenario	Generation within SPP	
	Summer	Winter
Without the Gen-2002-022	44289	32743
GEN-2002-022 at 100% output with the prior queued projects	44368	32822

Table 5: Generation in SPP Area

6. SIMULATION RESULTS

Initial power flow studies were carried out to determine the power factor required at the POI in order to keep the voltage at the 230 kV bus at 1.0 per unit for the contingencies listed in Table 1. It was found that a power factor of 0.968 is required at Bushland 230 kV in order to maintain the POI at 1.0 pu unit voltage.

Initial dynamic simulation was carried out without any disturbance to verify the numerical stability of the model and was confirmed to be stable.

Table 6 provides the summary of the stability studies for GEN-2002-022.

Simulation results show that there are no issues with angular or voltage stability for the contingencies that were studied.

Fault Number	Summer Peak Load Case	Winter Peak Load Case
FLT13PH	--	--
FLT21PH	--	--
FLT33PH	--	--
FLT43PH	--	--
FLT51PH	--	--
FLT63PH	--	--
FLT71PH	--	--
FLT83PH	--	--
FLT91PH	--	--
FLT103PH	--	--
FLT111PH	--	--

FLT123PH	--	--
FLT131PH	--	--
FLT143PH	--	--

UV : GEN-2002-022 Tripped due to low voltage
 OV : GEN-2002-022 Tripped due to high voltage
 UF : Tripped due to low frequency
 OF : Tripped due to high frequency
 PQ : Prior Queued Projects Tripped
 S : Stability issues encountered
 -- : Wind Farm did not trip

Table 6: Stability Study Results Summary

The system responses corresponding to FLT13PH are shown in Figure 3.

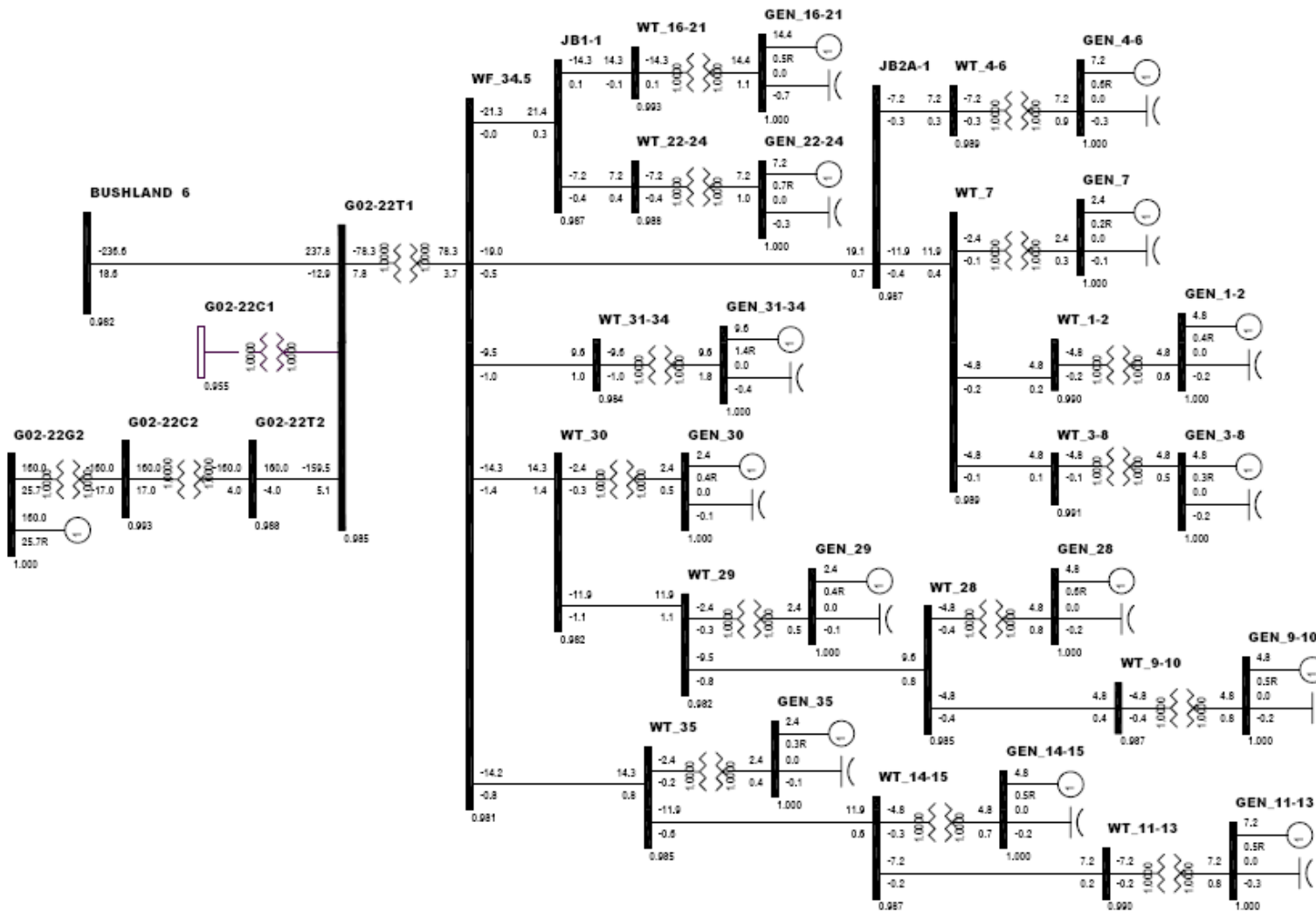

Figure 2: 100% Power Flow Base Case for GEN-2002-022

7. SUMMARY

A transient stability analysis was conducted for the SPP Interconnection Generation Queue Position GEN-2002-022 consisting of Mitsubishi 2.4 MW wind turbines, for an aggregate output of 79.2 MW. The study was conducted for two different power flow scenarios, i.e., one for summer peak and one for winter peak load cases.

The study has indicated not indicated any angular or voltage instability due to the addition of Gen-2002-022.

Also, a power factor of 96% at the POI is required to maintain a 1.0 pu voltage for the most severe contingency.

Disclaimer

If any previously queued projects that were included in this study drop out, then this System Impact Study may have to be revised to determine the impacts of this Interconnection Customer's project on Xcel Energy (SPS) transmission facilities. Since this is also a preliminary System Impact Study, not all previously queued projects were assumed to be in service in this System Impact Study. If any of those projects are constructed, then this System Impact Study may have to be revised to determine the impacts of this Interconnection Customer's project on Xcel Energy transmission facilities. In accordance with FERC and SPP procedures, the study cost for restudy shall be borne by the Interconnection Customer.

Figure 3 : System Responses with 100% output of GEN-2002-022 for FLT13PH

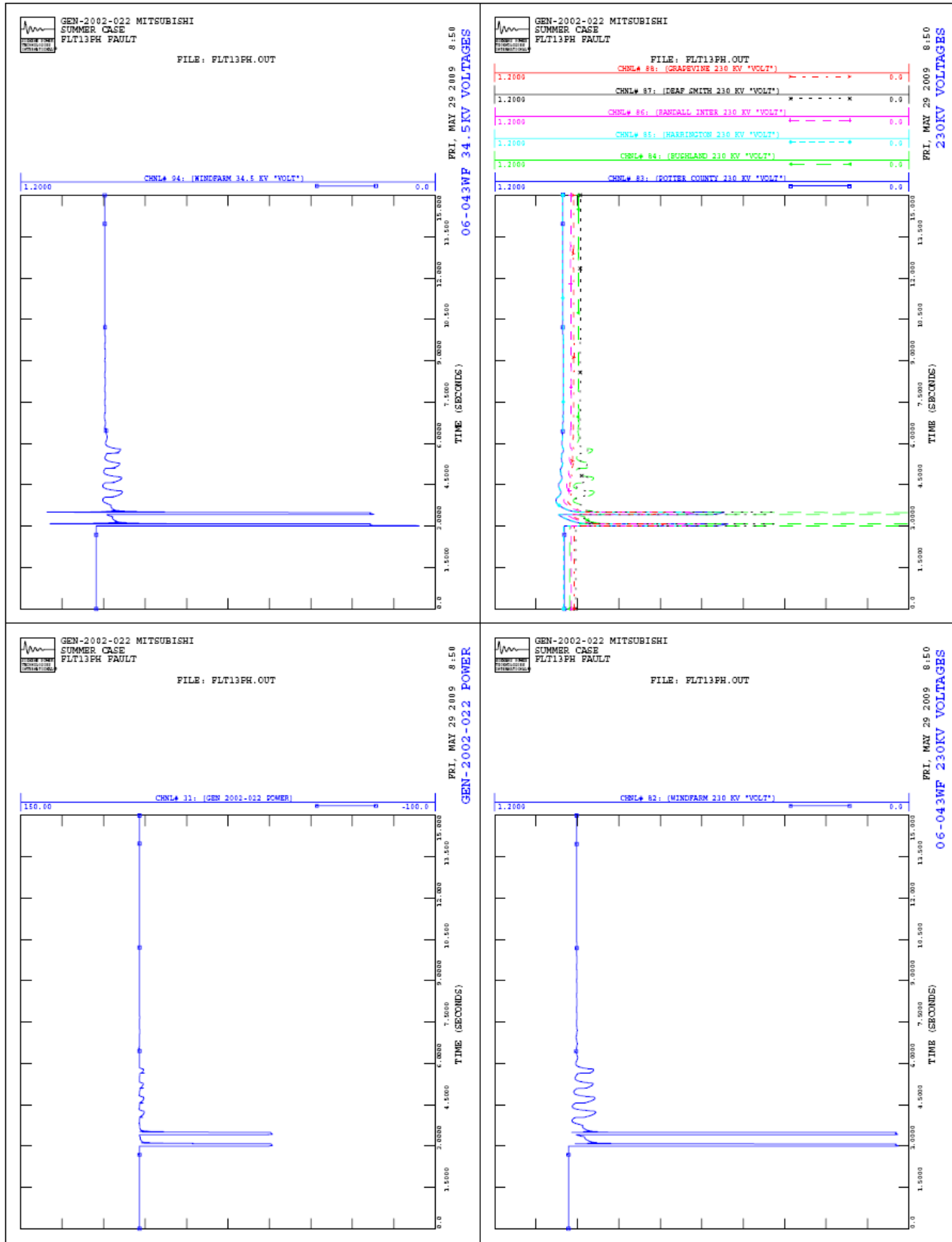

Figure 3 : System Responses with 100% output of GEN-2002-022 for FLT13PH (Cont'd)

