



FACILITY STUDY

For

< OMITTED TEXT >

80 MW Wind Generating Facility
Hansford, County, Texas
SPP #GEN-2002-009

August 2, 2004

Xcel Energy Services, Inc.
Transmission Planning

Executive Summary

The Customer < OMITTED TEXT> requested the interconnection of a wind energy project to Southwestern Public Service Company's (SPS) 115 kV transmission line. This project is a new wind energy generation facility located approximately 6 miles south of the Oklahoma – Texas state line, along SPS's Texas County Interchange to Spearman Interchange 115 kV transmission line. The Southwest Power Pool (SPP) evaluated the request to interconnect this 80 MW wind energy facility to the SPS transmission system in a System Impact Study completed February 10, 2004. This wind energy project will consist of 44 Vestas V80 wind turbines with a rated output of 1.8 MW each, for a nominal output of 80 MW.

Xcel Energy will construct a three breaker switching station bisecting the Texas County Interchange to Spearman Interchange 115 kV transmission line near the point of interconnection. This new station will consist of a three breaker 115 kV ring bus, a control house for the required SCADA, electronic metering and system protection. The existing 115 kV transmission line will be routed in and out of the new switching station, with 115 kV breakers on both lines towards Texas County Interchange and Spearman Interchange.

A Certificate of Convenience and Necessity from the Public Utility Commission of Texas is not required for the construction of the new switching station.

The Requester is responsible for the cost of the Requester's Interconnection Facilities, inclusive of all construction of the 115 kV transmission line from the Requester's generation facility to the new SPS switching station.

It is anticipated that the construction of the new switching station, for the acceptance of electric power from the Requester's Wind Farm, will require approximately 10 months for completion. The cost of this network upgrade, required for the interconnection of this new wind energy generation facility, is shown below:

Stand-alone Network Upgrade:	\$ 1,884,214
Network Upgrade:	\$ 469,409
Operating Expense:	\$ 10,000
Interconnection Facilities :	\$4,200
<hr/>	
Total:	\$ 2,367,823

A detailed description of all costs associated with the construction of this new switching station is shown in Table 1.

Discussion

General Description of Existing Facilities

The new switching station required to connect the requestor's wind-generated power plant will be located adjacent to the existing Texas County Interchange (south of Guymon, Oklahoma) to Spearman Interchange 115 kV transmission line. The switching station will be constructed in the northwest corner of Survey 36, Block P, Houston and Great Northern Railway Survey. The new switching station will consist of a three breaker 115 kV ring bus design, with expansion capability to a breaker and a half configuration. The existing adjacent transmission line will be routed in and out of the new switching station with 115 kV breakers on both lines towards Texas County Interchange and Spearman Interchange. Figure A - 2 shows the interconnection one-line diagram for this wind-generated energy project.

General Description of Modifications and New Facilities

1. **Construction of New 115 kV Switching Station:** See Figure A - 3 in Appendix A for one-line diagram and Figure A - 7 for a plan view of the station.
 - 1.1. **Location:** Xcel Energy will construct a new 115 kV switching station at the interception point to the Xcel Energy transmission circuit V68, located approximately 6 miles south of the Texas–Oklahoma state line on the northwest corner of Survey 36, Block P, Houston and Great Northern Railway Survey. See Figure A - 1 for map of area.
 - 1.2. **Bus Design:** This station is being built as a 3-breaker ring expandable to a 2 string breaker-and-a-half with 4 lines out. There will also be enough ROW for an ultimate design of 6 lines and three strings of breaker-and-a-half. Three additional switches will be installed to make future additions possible without requiring bus outages.
 - 1.3. **Line Terminals:** The 115 kV line and static wire terminals will be designed to accommodate 2,000 pounds per phase conductor at maximum tension, with a maximum 15 degree pull off from normal.
 - 1.4. **Control House:** A control house approximately 12 feet by 20 feet will be installed to contain the metering, protection and control devices, terminal cabinets, and any fiber-optic cable terminations, etc.
 - 1.5. **Security Fence:** The switching station will have a chain-link fence with steel posts set in concrete and a rock yard surface.
 - 1.6. **Ground Grid:** A complete ground-grid will be installed per ANSI/IEEE STD 80-1986, with our standard 4/0 copper ground mesh on 40-foot centers with ground rods and 20-foot centers in corners and loop outside of fence.

- 1.7. **Site Grading:** Company contractor, per company specifications, will perform initial site grading and erosion control of the interconnection facility. Soil compaction shall be not less than 95% of laboratory density as determined by ASTM-D-698.
- 1.8. **Station Power:** A 66kV/120-240 volt transformer tapped on one set of the PTs will provide station power. A backup station power source will be taken from local distribution if it is available or a generator will be installed if none is available. A flip-flop to automatically transfer the station power will be installed.
- 1.9. **Relay and Protection Scheme:** See Figure A - 6 for switching station relaying one-line.

The new Switching Station to Texas County line relaying will be directional comparison blocking (DCB) over power line carrier with a Pulsar TC10B. A SEL 321-1 (DCB) and a SEL 311-C (step distance) will be used. A SEL 279H-2 relay will be used for reclosing and a SEL 501-0 will be used for breaker failure.

The new Switching Station to Spearman Sub line relaying will be directional comparison blocking (DCB) over power line carrier with a Pulsar TC10B. A SEL 321-1 (DCB) and a SEL 311-C (step distance) will be used. A SEL 279H-2 relay will be used for reclosing and a SEL 501-0 will be used for breaker failure.

The new Switching Station to Requester's wind farm line relaying will be step distance. A SEL 321-1 and a SEL 311-C will be used. A SEL 279H-2 relay will be installed; however **there will not be any automatic reclosing**. The SEL 279H-2 will be used for line/bus conditions and sync check along with supervisory closing of the breaker. A SEL 501-0 will be used for breaker failure.

Two sets of 115 kV PTs will be installed on the north and south buses with disconnect switches. There will be provisions made for an automatic throw-over of the PTs. A manual transfer switch will be available for maintenance purposes.

On the Texas County and Spearman line there will be single CCVT's for line conditions. A line tuning unit and wave trap will also be installed for the PLC communications.

The bus voltage and GCB amps will be the SATEC PM type meters that shows all three phases eliminating the need for a switch and transducers.

The batteries will be our standard set of 306 or 204 AH Varta batteries with a 35 or 25 amp charger.

- 1.10. **Revenue Metering:** On the line to the Requester's wind farm, billing meters will be installed along with a 115 kV metering unit (3 PTs and 3 CTs) for full 3 phase 4 wire metering. The metering unit will have 1000/600:1 PTs and 200/400:5 CTs. There will be two meters one will be primary and the other will be back-up, each will have full 4 quadrant metering. Pulses out of the primary billing meter will be sent via SCADA to the Amarillo Control Center.

1.11. **Communications:** The RTU will be our standard small 5700 RTU with communications. A SEL 2020 will be installed for relay communications and other functions as required

Communications from the substation to the Amarillo Control Center will consist of a 4-wire telephone data circuit provided by the Requester if it is available. If it is not available, some type of communications will have to be installed to get the metering data to the Amarillo Control Center, along with the RTU information.

A station telephone will be installed in the control house if service is available. A telephone switch will be installed to transfer between the SEL-2020 and the billing meters along with the station talk service.

A schematic outlining the proposed construction is provided below:

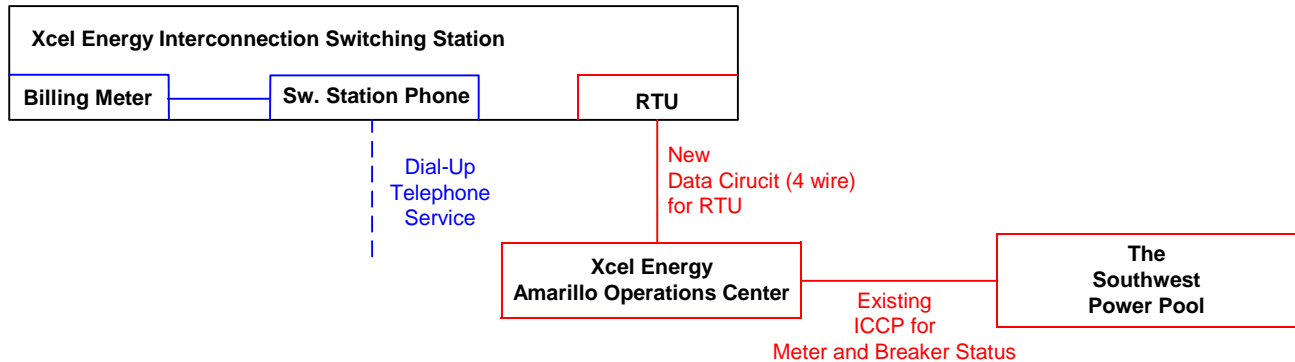

2. Transmission Line:

The Requester will construct, own, operate, and maintain the new 115 kV line that will tie their 115/34.5kV substation to the new Switching Station.

2.1. **115 kV Line Terminations:** The Requester will build the 115 kV tap line and terminate the line into our substation’s dead-end steel. Xcel Energy will provide the lightning arresters, which will be interconnection facilities, for protection of the Requester’s line on Xcel Energy’s dead-end tower. The Requester will provide the dead-end material and the actual dead-ending of the phase conductors and static. Xcel Energy will provide an attachment point on the substation steel for the Requester’s dead-end material.

For the phases, the Requester will provide a single tongue two-hole pad for SPS to run the final jumpers. The attachment point will be a horizontal hole on the ½” thick steel 11/16” in diameter (made for a 5/8” bolt) at a height of 40 feet above our foundations. The maximum tension is 2000 lbs per conductor with a maximum 15-degree pull-off from normal.

For the static the Requester will dead-end their static to a vertical hole on ½” thick steel 1” in diameter at a height of 55 feet above our foundations. The maximum tension is 2000 lbs per conductor with a maximum 15-degree pull-off from normal.

See Figure A - 4 for Point of Interconnection and Change of Ownership.

3. **Right-Of-Way:**

- 3.1. **New 115 kV Transmission Line:** It will be the Requester's responsibility to perform all necessary tasks associated with the procurement of real estate or right-of-way, inclusive of all surveying, title search, etc., for the Requester's transmission line.
- 3.2. **Permitting:** Currently, permitting for substation construction is not required in the State of Texas and the short 115 kV lines into the new switching facility do not require permitting due to their length being less than one mile.
- 3.3. **Switching Station Location:** Figure A - 5 shows the desired location for this new SPS Switching Station. The new switching station will be constructed at this location assuming the land can be procured from the landowner.

4. **Relay Upgrades at Texas County Interchange:** At Texas County, the breaker relaying will be upgraded to a directional comparison blocking (DCB) over power line carrier with a Pulsar TC10B. A SEL 321-1 (DCB) and a SEL 311-C (step distance) will be used. A SEL 279H-2 relay will be used for reclosing and a SEL 501-0 will be used for breaker failure.
5. **Relay Upgrades at Spearman Interchange:** At Spearman Interchange, the breaker relaying will also be upgraded to a directional comparison blocking (DCB) over power line carrier with a Pulsar TC10B, similar to the one at Texas County.
6. **Construction Power and Distribution Service:** Both Construction and Station power, in addition to any distribution service required for the wind facility are, the sole responsibility of the Requester.

All additional cost for work not identified in this study is the sole responsibility of the Requester unless other arrangements are made.

7. **Interconnection Power Factor**

The power factor at the interconnection point shall be 99% or better during steady state conditions at full output.

8. Estimated Construction Costs

The projects required for the interconnection for the 80 MW wind generating facility consists of the project summarized in the table below:

Table 1, Required Interconnection Projects

Project	Description	Estimated Cost
	Stand-alone Network Upgrade	
1	Switching Station, 115 kV Ring Bus	\$ 1,647,776
2	Control House	\$ 186,438
3	Right-of-Way Cost (station land, surveying, etc.)	\$ 50,000
	Subtotal:	\$ 1,884,214
	Network Upgrade	
4	Communications Cost	\$ 50,000
5	Possible RTU at Wind Farm Site	\$ 50,000
6	Relaying Changes, Texas County Interchange	\$ 86,846
7	Relaying Changes, Spearman Interchange	\$ 122,563
8	115 kV Transmission Line Work	\$ 160,000
	Subtotal:	\$ 469,409
	Operating Expense	
9	Mobile Substation Expense	\$ 10,000
	Subtotal:	\$ 10,000
	Interconnection Facilities	
10	115 kV Arresters	\$ 4,200
	Subtotal:	\$ 4,200
	Total Cost:	\$ 2,367,823

9. Engineering and Construction Schedule

It is anticipated that the switching station and all associated components will be constructed and ready to receive power from the Requester's wind farm approximately 10 months from the day an interconnection agreement is signed, unless prior arrangements have been made. This is the earliest Xcel Energy can initiate the project as a result of other scheduling considerations. An Engineering and Construction schedule is shown below:

ID	Task Name	Duration	Year 1														
			9	10	11	12	1	2	3	4	5	6	7	8	9	10	11
1	Right-of-Way Process	40 days?															
2	Obtain Substation Site	6 wks				1/5											
3	Right-of-Way Completion	10 days?															
4																	
5	Substation - Switching Station Project	190 days															
6	Engineering complete	8 wks				1/5											
7	Substation site Survey	2 wks															
8	Dirt prints complete	8 wks				1/5											
9	Dirt bids	2 wks															
10	Dirt pad & road work	6 wks															
11	115 kV Breakers delivery date	14 wks															
12	Material order & delivery	18 wks															
13	Manifest Construction drawings	8 wks															
14	Fence Construction	2 wks															
15	Foundation work complete	5 wks															
16	Substation construction	12 wks															
17	Testing and inspection	1 wk															
18	Commission Substation	2 wks															
19																	
20	Transmission Line Project	124 days?															
21	Engineering	4 wks															
22	Transmission line design	8 wks															
23	Manifest Construction Drawings	1 day?															
24	Material order and delivery	16 wks															
25	Temporary line for substation construction	2 wks															
26	Foundations complete	2 wks															
27	Structures Installed	2 wks															
28	Wire work	1 wk															
29	Remove temp. line & energize to sub.	3 wks															
30	Transmission Completion	1 day?															

Appendix A

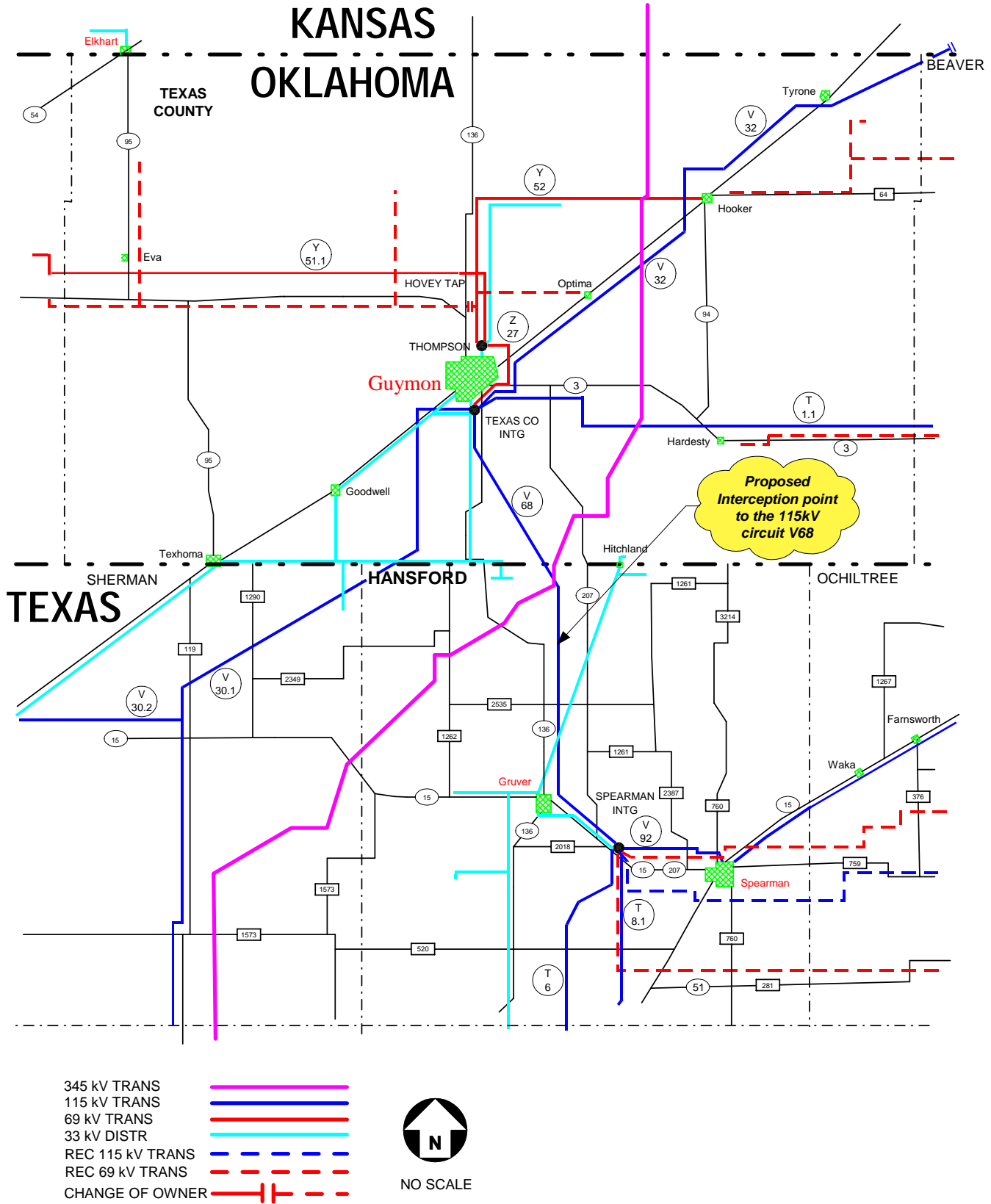

Figure A - 1 Proposed Interception Point to the Xcel Energy 115 kV Circuit V68.

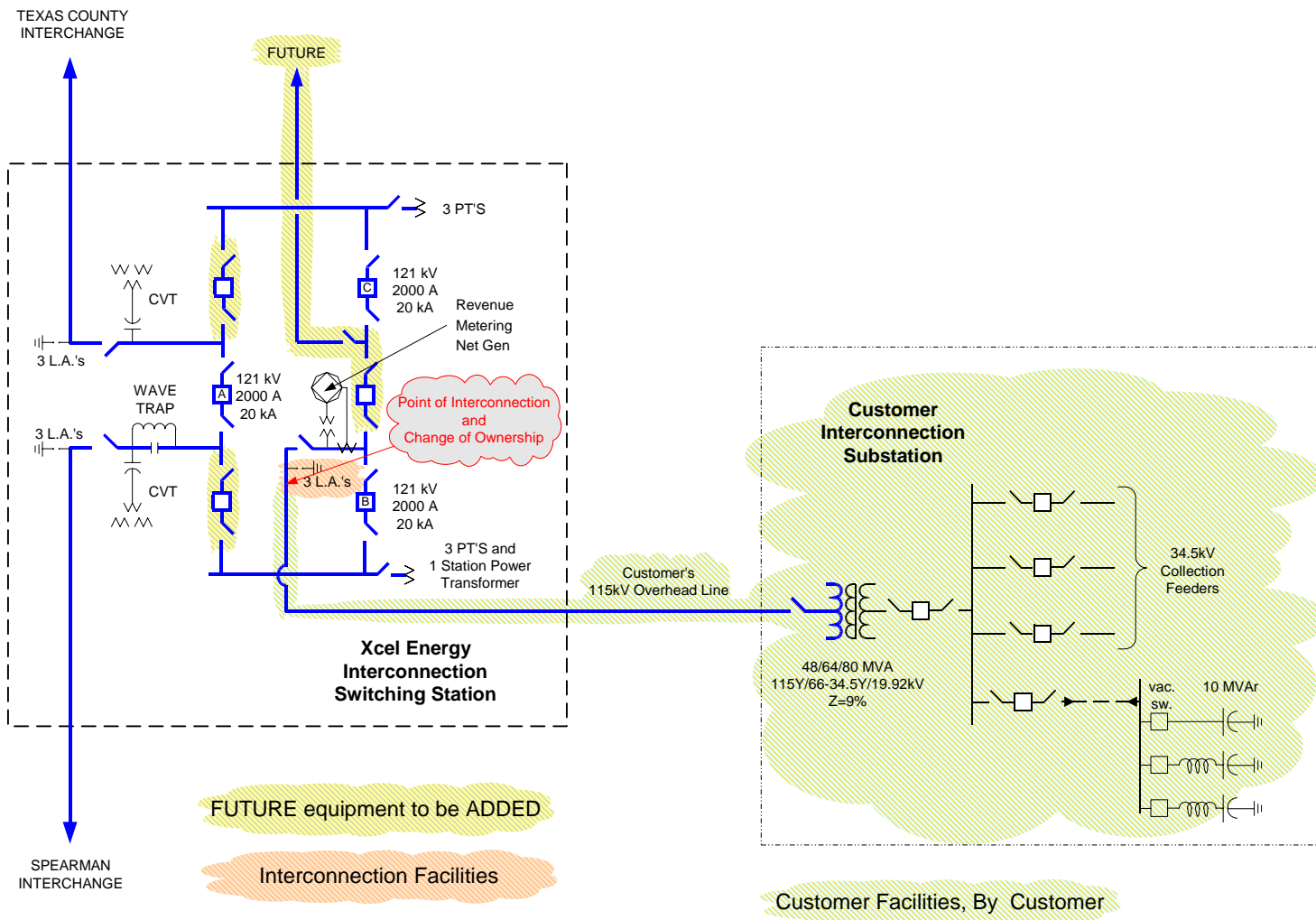
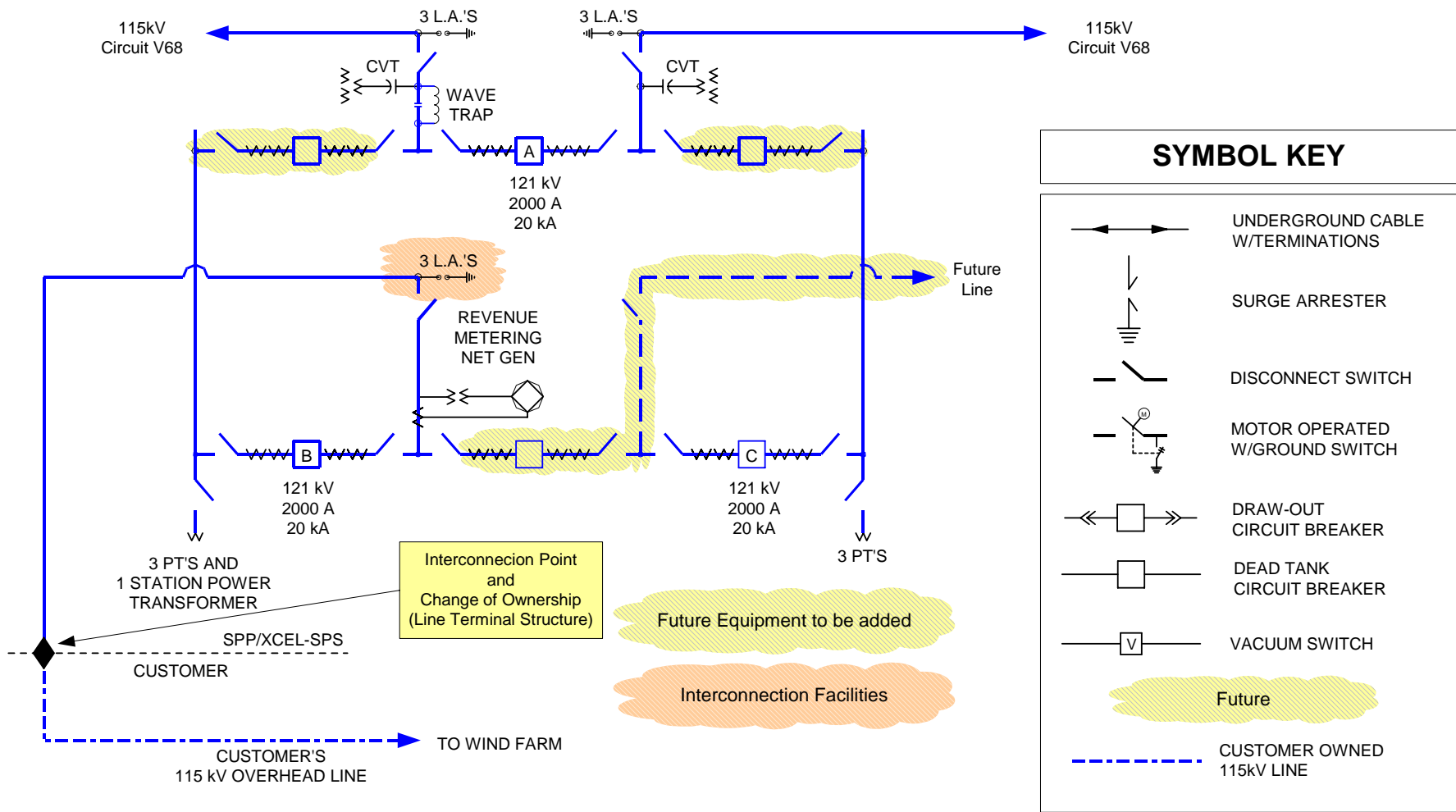

Figure A - 2, Interconnection One-Line Diagram



115kV SWITCHING STATION

Figure A - 3, Switching Station One-line Diagram

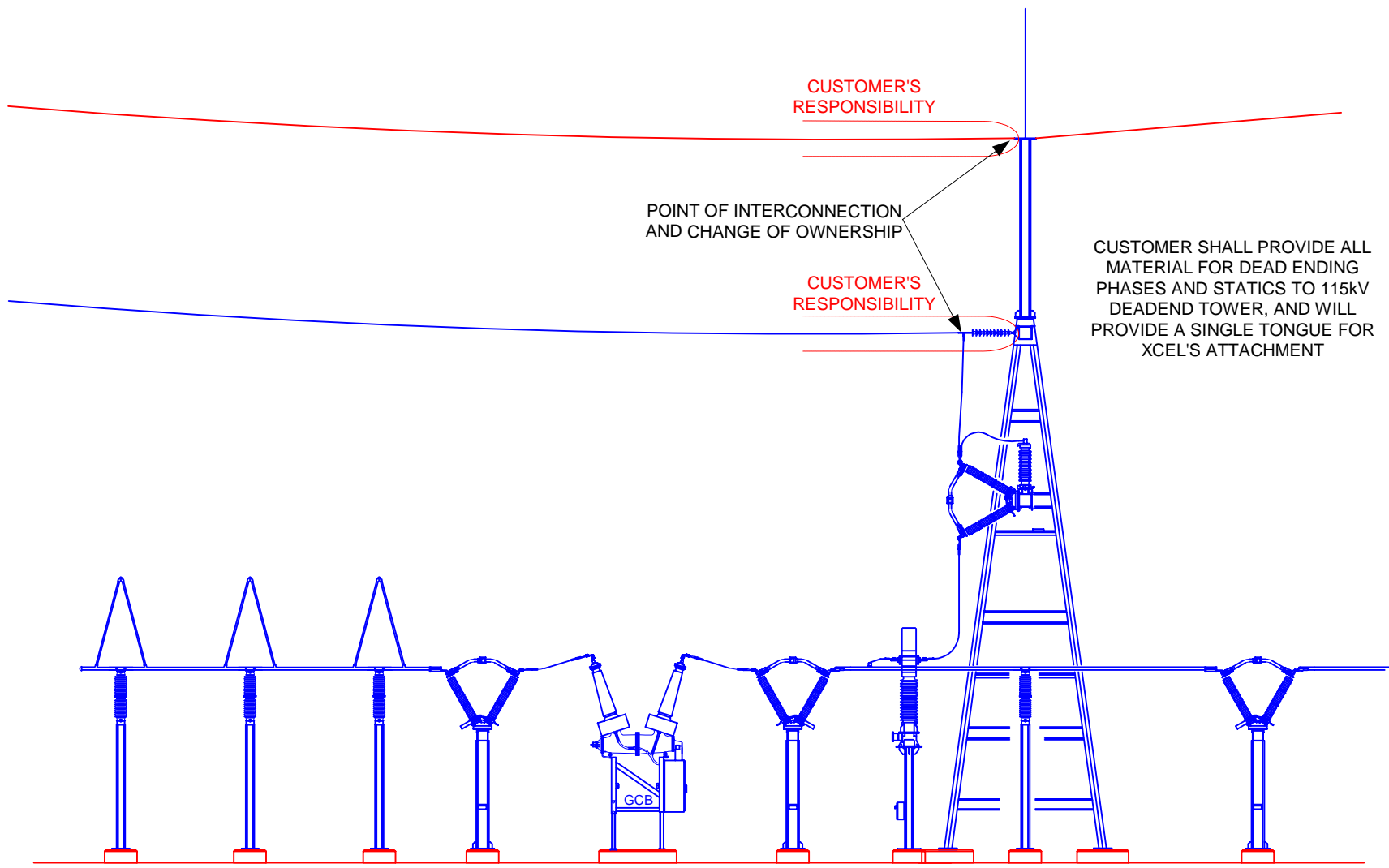

Figure A - 4, Point of Interconnection & Change of Ownership

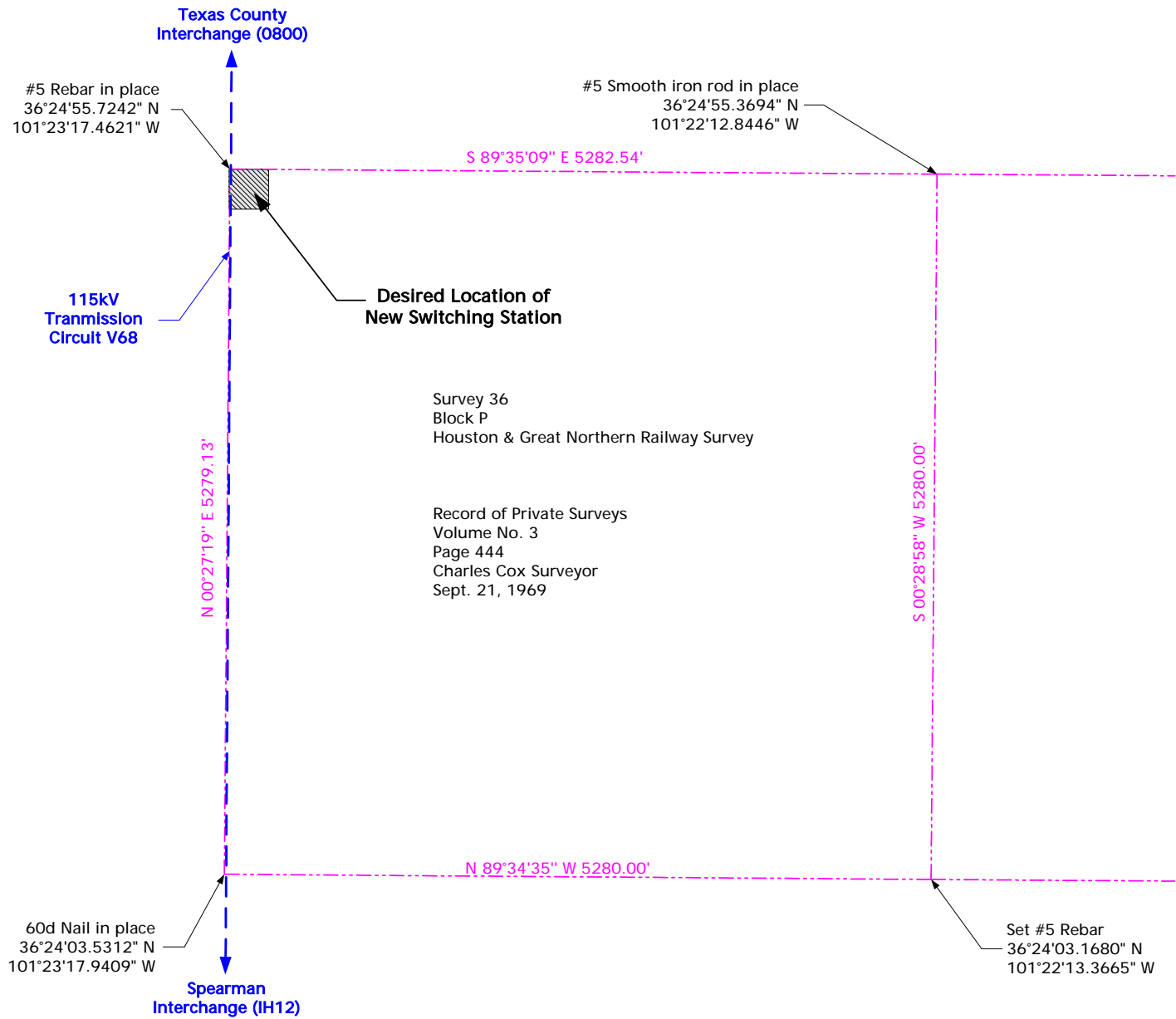

Figure A - 5, Switching Station Location

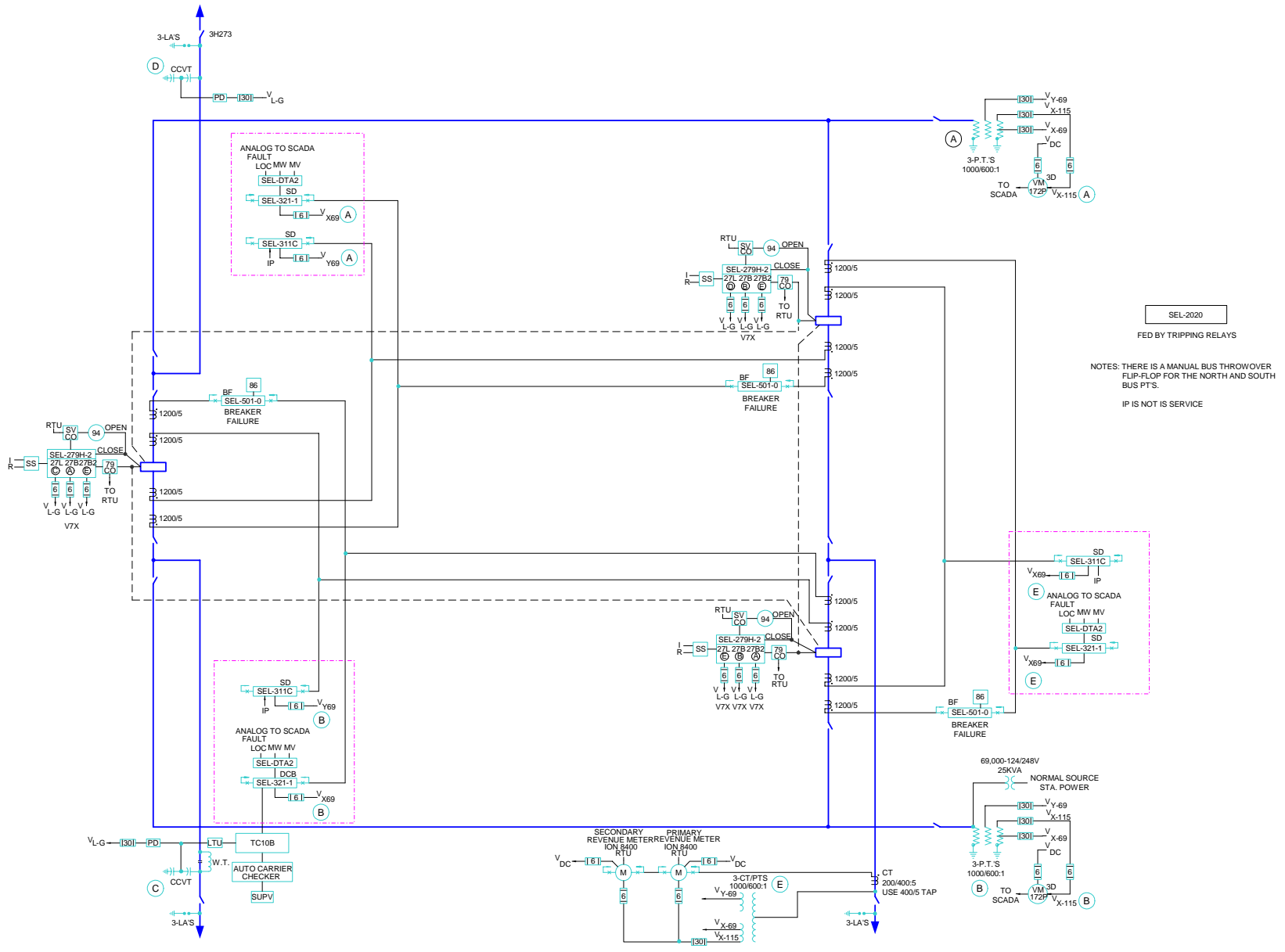

Figure A - 6, Switching Station Relaying One-Line

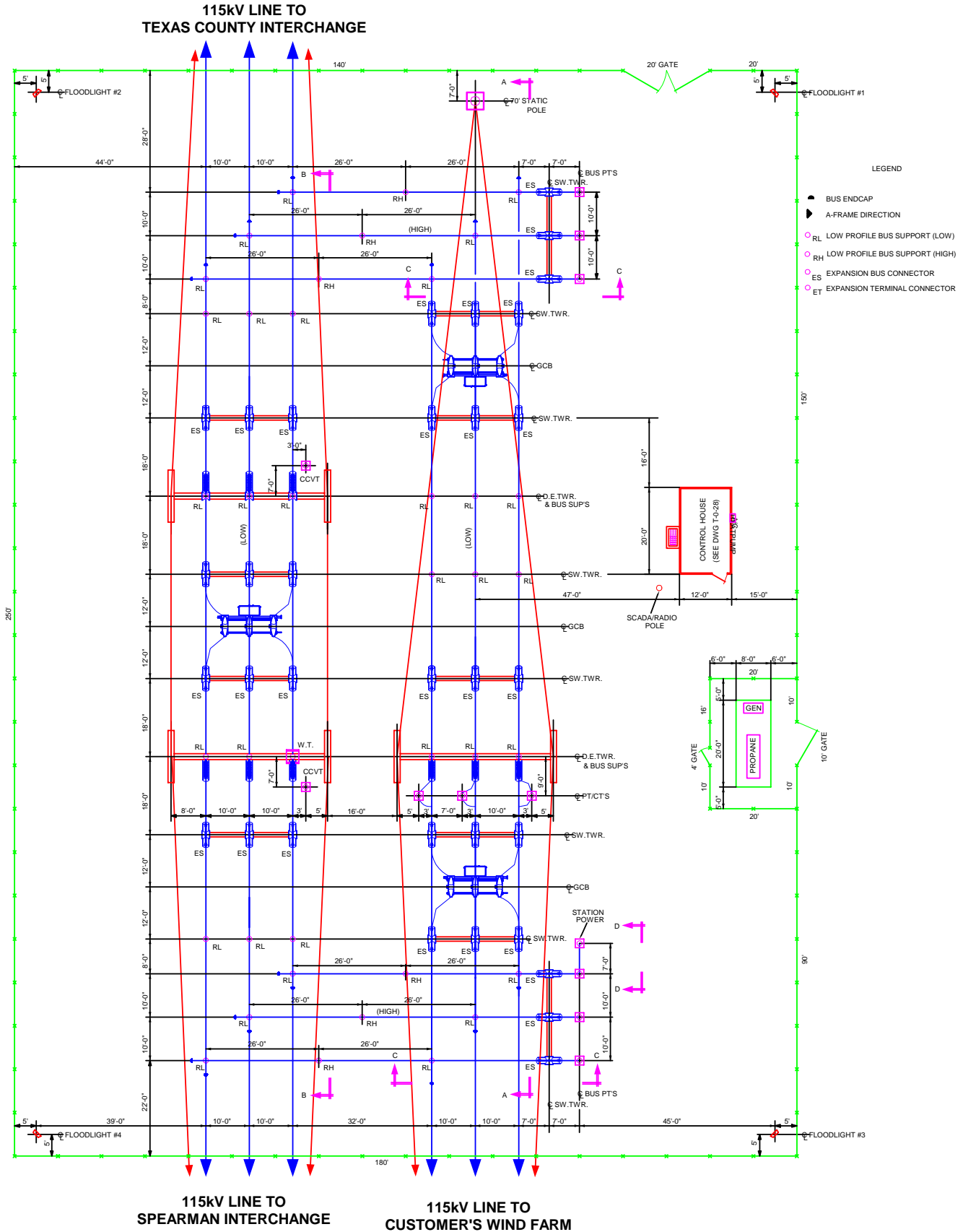

Figure A - 7, Switching Station Plan View